

P24-09
Event Center and Parking Lot

Property Owner: Legacy Hotel of Medina LLC
 Applicant: Ian Jones
 Location: 253/257 South Court Street and 226 South Elmwood Avenue
 Zoning: C-2 (Central Business)
 Request: Conditional Zoning Certificate and Site Plan approval for the construction of an event center and parking lot

LOCATION AND SURROUNDING USES

The subject site is composed of three properties encompassing 1.49 acres located between South Court Street and South Elmwood Avenue. Adjacent properties include the following uses and zoning:

- North – Retail (C-2) and Parking (P-F)
- South – Parking Lot (P-F) and Personal Service (C-2)
- East – Retail and Entertainment (C-2)
- West – Parking (P-F) and Single-Family Residential (R-3)

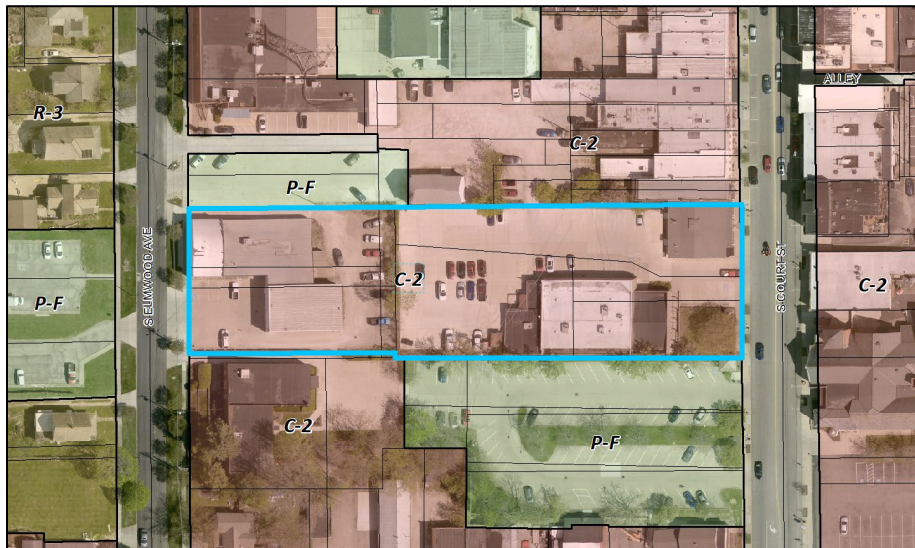

BACKGROUND & PROPOSED APPLICATION

The eastern 0.96 acre property received conditional approval from the Historic Preservation Board (H22-19), Planning Commission (P22-19), and Board of Zoning Appeals (Z22-24) for the demolition of two buildings at 253 and 257 South Court Street and the construction of a hotel in 2022. The approvals were extended by the Boards and Commission in late 2023.

The current application proposes the construction of a 5,800 sq. ft. event center and associated parking at 253 and 257 South Court Street to the rear of the previously approved hotel. The current application does not alter or affect previous approvals concerning the demolition of two buildings at 253 and 257 South Court Street or the construction of a hotel.

The applicant recently acquired two additional properties to the west of the hotel site at 226 South Elmwood Avenue, which encompass approximately 0.53 total acres. The current project proposes the demolition of the existing NAPA Auto Parts building at 226 South Elmwood Avenue and the construction of a parking lot.

The Historic Preservation Board will hear a Certificate of Appropriateness application and the Board of Zoning Appeals will hear Variance applications for the project on March 14th and March 12th, respectively.

CONDITIONAL ZONING CERTIFICATE

Per Section 1135.03, an event center (“Conference Center, Banquet Facility, or Meeting Hall”) is a conditionally permitted use in the C-2 zoning district. An event center does not have any specific conditionally permitted use regulations, however, the use is subject to the general regulations below.

Conditional Zoning Certificate Basis of Determination

The Planning Commission shall establish beyond reasonable doubt that the general standards and the specific standards pertinent to each use indicated herein are satisfied by the completion and operation of the proposed development. The Planning Commission may also impose such additional conditions and safeguards deemed necessary for the general welfare, for the protection of individual property rights and for the insuring that the intent and objectives of this Zoning Ordinance will be observed.

The Planning Commission shall review the particular facts and circumstances of each proposed use in terms of the following standards and shall find adequate evidence showing that such use on the proposed location:

- (1) Will be harmonious with and in accordance with the general objectives or with any specific objectives of the Land Use and Thoroughfare Plan of current adoption;
- (2) Will be designed, constructed, operated and maintained so as to be harmonious and appropriate in appearance with the existing or intended character of the general vicinity and that such use will not change the essential character of the same area;
- (3) Will not be hazardous or disturbing to existing or future neighboring uses;
- (4) Will not be detrimental to property in the immediate vicinity or to the community as a whole;
- (5) Will be served adequately by essential public facilities and services such as highways, streets, police and fire protection drainage structures, refuse disposal and schools; or that the persons or agencies responsible for the establishment of the proposed use shall be able to provide such service adequately;
- (6) Will be in compliance with State, County and City regulations;
- (7) Will have vehicular approaches to the property which shall be so designed as not to create an interference with traffic or surrounding public streets or roads.

SITE PLAN

Development Standards

The following table indicates the general development standard requirements of the C-2 zoning district:

	Required	Proposed
Max Building Footprint	5,000 sq. ft.	5,800 sq. ft.
Required Front Setback (Parking)	10 ft.	10 ft.
Minimum Side Building Setback	0 ft.	22 ft./52ft.
Minimum Rear Building Setback	0 ft.	19 ft.
Max Building Height	40 ft., 60 ft. w/PC Approval	20 ft.

The applicant has filed a variance request to the Board of Zoning Appeals to exceed the maximum building footprint (Section 1135.05).

Parking, Access, and Circulation

Access and Circulation – The site includes the reconfiguration of two full existing access drives to South Elmwood Avenue to the west, a full access drive to the city parking lot to the south, and a one-way egress drive to a county parking lot to the north. A drop-off lane is also indicated on the west side of the event center.

Section 1145.10(c) states that parking spaces shall not be located along entry drives within 20 ft. of the right-of-way. Parking spaces on the west side of the site are located 10 ft. from the right-of-way. The applicant has filed a variance request to the Board of Zoning Appeals regarding this requirement.

Off-Street Parking – The property is in a parking-exempt district and does not require a minimum number of parking spaces. However, the proposed parking areas to the south and west of the event center include 61 total on-site spaces. The site is also adjacent to public parking areas to the north (County Lot - 23 spaces), south (City Lot 4 - 77 spaces), and west (City Lot 5 - Approximately 40 spaces). In addition, there have been discussions regarding upgrading City Lot 5 on the west side of South Elmwood Avenue, which is currently in poor condition and does not utilize the entire site.

Parking spaces and aisles meet the required dimensional requirements of Section 1145.08, which requires 9 ft. x 19 ft. 90-degree spaces with 24 ft. two-way aisles and 9 ft. x 23 ft. parallel spaces with 18 ft. two-way aisles.

Parking Supply and Demand Analysis – Per Section 1145.04(d), as the property is within the Downtown Parking District, the project is not subject to the minimum parking requirements of Section 1145.04. For the initial hotel development, a Parking Supply and Demand Analysis was required to be completed. The analysis was conducted by TMS Engineers, Inc. and accepted by the City Engineer. A revision to the analysis will be necessary to reflect the revised project.

Sidewalk – A public sidewalk exists along South Elmwood Avenue and will be reconfigured/ reconstructed with the project. In addition, a private sidewalk extends from South Elmwood Avenue to South Court Street providing pedestrian access to the site.

Landscaping, Screening, and Buffering

Landscaping

- Landscaped areas are provided to the south and west of the building, along the south property line, and along the proposed private sidewalk.
- Required landscaping within the parking lot exceeds minimum requirements and parking lot islands include landscape material.
- Landscaping is provided within the 10 ft. setback between the parking lot and the right-of-way.
- Two street trees are currently located along South Elmwood Avenue, which are shown to be replaced.

Fencing – A 6 ft. tall black chain link fence with privacy slats is located along the north property line.

Trash Enclosure – A trash enclosure is shown on the south side of the site with 7 ft. brick walls and a black metal gate in compliance with Section 1155.05(a).

Utilities

The property has access to sanitary sewer service to the north and access to water service from South Court Street. The proposed Site Plan has less impervious surface than the existing site, however, the applicant will need to work with the City Engineer regarding storm water requirements.

Engineering Department Comments

The City of Medina Engineering Department has reviewed the submitted plans and has provided comments included in the application packet. Comments generally include the following:

- A necessary sanitary sewer easement located between the proposed hotel and event center will need to incorporate language regarding the property owner's responsibility for restoring the patio area and ancillary damages to structures if the sewer needs to be accessed.
- A storm water management plan and operations and management agreement will be required.
- The necessity of the northern access point and easement should be evaluated as the revised site plan includes two full access points on South Elmwood Avenue and a full access point to the city parking lot to the south. If the access point is necessary, the drive will need to be updated to public road standards and a traffic management/pavement parking plan should be developed.
- An update to the previously submitted Parking Supply and Demand Study will be required.

Fire Department Comments

The City of Medina Fire Department has reviewed the revised plans and has provided the following comments:

- The location of the fire hydrant must be moved to the west side of the south entrance.
- The dumpster should be moved to the west of the location currently shown so as not to further impede access to the east. (Revised plans relocate the dumpster to the west as requested)
- Install a man gate in the north chain link privacy fence, in the area of the proposed patio. This man gate should have panic hardware to allow for emergency egress through the fence to the north. The gate may, at the owner's discretion, be marked for "Emergency Exit Only", and is not required to have entry hardware on the north side.

Building Elevations and Lighting

The proposed event center is a one-story building, 20 ft. in height, with higher parapet walls on the northern section of the building. The building is predominantly clad in brick with two lower courses of cast stone and a cornice on the northern section of the building. The building contains entrance doors on the east and west sides of the buildings surrounded by large glass “Curtain Walls” and flat awnings.

Renderings have been provided showing the building in context with the area. The renderings depict the proposed building and site from multiple perspectives and angles.

The site is located in the City of Medina Historic District and is subject to Chapter 145 of the Codified Ordinances, which will be considered by the Historic Preservation Board in their review. In addition, the Planning and Zoning Code also includes architectural standards applicable to the project.

A lighting plan will have been submitted in compliance with Section 1145.09(c) including a photometric plan and full cut-off fixtures. Parking lot lights are limited to 10 ft. in height, unless a taller height is authorized by Planning Commission. The applicant has requested a parking lot light height of 15 ft., which is lower than commonly found in commercial areas.

Downtown Medina Strategic Redevelopment Plan

The Downtown Medina Strategic Redevelopment Plan was completed in 2014 to establish a vision for the downtown and identify redevelopment possibilities. The Plan provides concepts of potential redevelopments, including a Development Area that incorporates a hotel with 100 and 122 rooms, a 6,000 sq. ft. event/conference center, and a restaurant. The Plan locates the hotel at a site bound by West Liberty Street, South Elmwood Street, and West Washington Street as part of a larger redevelopment.

As noted, the Plan provides only redevelopment concepts. Part 6 of the “How to Use the Plan” section of the plan is “Be Flexible” and notes “As projects, policies, and programs develop over time they may not look exactly like the images in the document, but they should address the intent of the Plan”. In practical application, the Plan informs the city that a moderately sized hotel, an event/conference center, and a restaurant in the downtown area are viable assets. The Plan does not limit the potential development to a specific location, size, or format.

Site Plan Review Standards

The Planning Commission's review and action shall be based on the following Standards per Section 1109.02(c):

- (1) The site plan shows that a proper relationship does exist between thoroughfares, service roads, driveways and parking areas to encourage pedestrian and vehicular traffic safety.
- (2) All the development features including the principal buildings, open spaces, service roads, driveways and parking areas are so located and related as to minimize the possibility of any adverse effects upon adjacent development.
- (3) The site plan includes adequate provision for the screening of parking areas, service areas and active recreation areas from surrounding properties by landscaping and/or ornamental walls or fences. All trees planted shall be as found in specifications approved by the Shade Tree Commission.
- (4) Grading and surface drainage provisions are reviewed and approved by the City Engineer.
- (5) The design and construction standards of all private streets, driveways and parking areas are to be built following approval of plans by the City Engineer according to construction standards specified in the Codified Ordinances.

- (6) Maximum possible privacy for multi-family dwellings and surrounding residential properties shall be provided through good design and use of proper building materials and landscaping. Visual privacy should be provided through structural screening and landscaping treatment. Auditory privacy in multi-family dwellings should be provided through soundproofing. All trees planted shall be as found in specifications approved by the Shade Tree Commission.
- (7) The architectural design of buildings should be developed with consideration given to the relationship of adjacent development in terms of building height, mass, texture, materials, line and pattern and character.
- (8) Building location and placement should be developed with consideration given to minimizing removal of trees and change of topography. Any trees to be removed which are planted in a public right-of-way or on municipal property shall be reviewed by the Shade Tree Commission.
- (9) In multi-family developments, television and other antennas shall be centralized.
- (10) On-site circulation shall be designed to make possible adequate fire and police protection.
- (11) Off-street parking facilities shall be provided in accordance with Chapter 1145. In large parking areas, visual relief shall be provided through the use of tree planted and landscaped dividers, islands and walkways. In multi-family developments no parking or service areas shall be permitted between any street and the main building. All trees planted shall be as found in specifications approved by the Shade Tree Commission.
- (12) Signs shall be provided in accordance with these Codified Ordinances.
- (13) Any trees planted on site shall be on approved list of Shade Tree Commission and planted in accordance with Commission standards.

COMMUNITY DEVELOPMENT DEPARTMENT STAFF RECOMMENDATION

Staff recommends approval of Site Plan and Conditional Zoning Certificate application P24-09 with the following conditions:

1. The demolition of two buildings and the construction of a hotel at 253 and 257 South Court Street conditionally approved by application P22-19 shall remain unchanged and any further amendment shall be subject to Site Plan and/or Conditional Zoning Certificate approval by the Planning Commission.
2. Plans shall incorporate changes requested by the Fire Department including the relocation of a fire hydrant to the west and the installation of an emergency egress gate in the fence along the north property line.
3. An update of the previously submitted Parking Supply and Demand Analysis, a storm water management plan, and a stormwater operations and management agreement shall be submitted and approved by the City Engineer.
4. The access point to the north shall be eliminated or the drive within the "Proposed 12' Egress Easement" shall be improved and a traffic management/pavement parking plan shall be submitted as required by the City Engineer.
5. Parking lot lights are permitted at a height of 15 ft.
6. The project shall comply with Planning and Zoning Code Sections 1135.06 regarding building footprint and 1145.10(c) regarding parking setbacks on an entry drive or a variance shall be approved by the Board of Zoning Appeals.

Andrew Dutton

From: Patrick Patton
Sent: Monday, March 4, 2024 4:45 PM
To: Andrew Dutton
Cc: Fred Himmelreich
Subject: Planning Commission Review P24-09
Attachments: Engineering Checklist for Commercial Site Plan.pdf

Andrew-

My comments:

1. Please refer to the attached engineering checklist for site plan approval.
2. The relocated public sanitary sewer will cross under a portion of the parking lot and the finished patio between the two buildings. The easement that will be granted to the City shall include language that if any maintenance or repair of the sewer that requires excavation in order to expose the sewer, once completed, while the excavation will be backfilled to grade level, however, the City nor the County Sanitary Engineers will not be responsible for restoring either the parking lot or the patio to their previous condition. In addition, the easement will absolve the City and the County of any liability for damage cause to either adjacent structure as a result of the work to maintain and/or repair the sewer.
3. As noted on the attached checklist, a storm water management analysis will be required. Please be aware that because the disturbed area of the revised project now exceeds 1 acre, the EPA will require that a storm water quality treatment system be included with the project. In addition, a storm water operations and management agreement between the property and the City will be required.
4. Regarding the proposed egress easement between the hotel property and the City's public right of way (unnamed alley), now that the revised site plan includes two access points to S. Elmwood Avenue directly from the hotel property, I wonder if a third access point is necessary. In addition, the City Law Director has determined that the easement is a private street and therefore must be constructed to the requirements of a public street. Lastly, as presented in the site plan, it is not clear how the flow of traffic between the one way egress from the hotel, the one way (east bound) traffic flow from the County parking lot, and the two way traffic flow from the public alley will be managed. I believe a more detailed traffic management plan/pavement marking plan should be developed for review. If the Commission does approve this access, I would ask that it is approved conditionally until that plan can be reviewed.
5. Previously a parking supply and demand study was completed for the hotel project. Now that the project will include the event center, which will certainly increase the parking demand at specific times, I would recommend that the study be updated.

Thanks,

Patrick Patton, PE
City Engineer
City of Medina, Ohio

Phone: (330) 721-4721
Email: ppatton@medinaoh.org
Website: www.medinaoh.org

Andrew Dutton

From: Larry Walters
Sent: Thursday, February 29, 2024 7:23 PM
To: Andrew Dutton
Cc: Mark Crumley
Subject: RE: Site Plan Review

Andrew,
Here are the comments regarding this plan. (All of the below are the same as our discussion in your office on Wednesday.)

1. The location of the fire hydrant must be moved to the West side of the South entrance.
2. The Dumpster should be moved to the West of the location currently shown so as not to further impede access to the East.
3. Install a man gate in the North chain link privacy fence, in the area of the proposed patio. This man gate should have panic hardware to allow for emergency egress through the fence to the North. The gate may, at the owner's discretion, be marked for "Emergency Exit Only", and is not required to have entry hardware on the North side.

Thank you,
Chief Walters

February 26, 2024
Revised March 11, 2024

Andrew Dutton
Community Development Director
The City of Medina
132 North Elmwood Ave.
Medina, OH 44256

Mr. Dutton,

This letter is in regard to a proposed event center on parcel 028-19A-21-397. This proposed event center modifies previous site plans for the recently approved hotel project on the same parcel and expands the site to parcels 028-19A-21-253, 028-19A-21-252. No site or design changes are proposed in this application east of the rear façade of the hotel.

Please consider this written narrative and detailed description applicable to the following application submittals: Site Plan, Conditional Zoning Certificate, Variance, and Certificate of Appropriateness (demolition & construction).

Certificate of Appropriateness (Demolition)

For the consideration of the Historic Preservation Board, our client is proposing to demolish the building at 226 S Elmwood Ave, currently a NAPA Auto Parts store, in its entirety. As described in the accompanying letter written by our client, the concrete masonry building is of no historical significance, and is not of a configuration and character that would make it desirable for reinvestment and rehabilitation. The demolition of the building will allow the site to be unified with the hotel site to the east and enable the addition of an event center to the overall development.

Written Narrative / Detailed Description (Site Plan, Conditional Zoning Certificate)

The new ~5,800 SF event center will be approximately 20'-25' feet west of the hotel. The hotel and event center are not joined due to a 20' easement that will be immediately west of the hotel. The hotel and event center will be served by staff and delivery areas immediately south of the event center. West of the event center will be a north/south drive aisle that provides a drop-off area for the event center and connects city parking to the south, and an unnamed alley to the north. West of this drive aisle, where the auto parts building currently resides would be used as a parking lot for the event center and hotel. Parking is a primary concern within the community, and without the demolition of this structure, the proposed event center would not be viable. A landscaped walkway is proposed on the north side of the parking lot for safe and convenient pedestrian access to the event center and hotel from S Elmwood Street.

To maximize the number of spaces in the parking lot, two curb cuts are proposed on S Elmwood Street. Two curb cuts currently exist on S Elmwood Street, however the new site plan adjusts the size and locations. Therefore, Planning Commission approval per 1135.08(b) is required.

A Conference Center, Banquet Facility, or Meeting Hall is a Conditionally Permitted Use per section 1135.05 of the zoning code. The proposed space will contain a warming kitchen, restrooms, storage for tables and chairs, pre-function spaces, and a large banquet room that will have the capability of being subdivided as needed. Outdoor spaces on the north and west of the event center will have controlled access and will be utilized for functions that

coincide with the hotel and event center. Due to food and beverages being available, this Outdoor Dining will be a Conditionally Permitted Use per section 1135.05 as well. These outdoor spaces will comply with Conditionally Permitted Use Regulations as defined in section 1153.04(a)(28) Outdoor Dining Facilities.

Included in our application is a photometric demonstrating site lighting design of the parking area. Multiple photometric studies were done considering light layout, efficiency, uniformity, adjacent properties, and luminaire heights. To meet the uniformity ratio in section 1145.09(c)(3) prescribing average illumination levels not exceeding four (4) times the minimum level, our design has the light source at fifteen (15) feet. This height exceeds the maximum height identified in section 1145.09(c)(5)(B) and requires the Planning Commission to approve the height per 1145.09(c)(5)(C). The photometric provided demonstrates that this extra height is necessary for the efficient illumination of the parking area and that the fixture heights will have no adverse effect on adjacent properties. We are asking for these luminaire heights to be approved by the Planning Commission.

Variance

Two variances are requested for the project.

A variance is requested for the new event center, due to the proposed size exceeding the 5,000 SF maximum building footprint allowed within the Public Square Area per 1135.06 Lot Development Standards. Based on experience of the hotel management company, Riley Hotel Group, the banquet hall must be at least 2,800 SF to accommodate the expected demands and needs of parties interested in renting the space for events such as conferences, weddings, etc. Due to necessary program elements accompanying the banquet hall, the total building footprint exceeds 5,000 SF by approximately 800 SF.

The driveway depth required per 1145.10(c) is twenty (20) feet. A variance is requested for (3) parking spaces to be eleven (11) feet from the right-of-way, nine (9) feet closer than allowed. The goal of this variance request is to maximize the number of on-site parking spaces available to guests of the event center and hotel. The additional parking spaces also help address concerns within the community regarding parking.

Certificate of Appropriateness (Construction)

The proposed building is composed of brick with stone-like accents, black windows, and a fiberglass cornice. The brick and stone products are identical to those previously approved by the Historic Preservation Board. The cornice is made of the same material as that approved on the hotel, however has a different profile and size due to the scale of the building. The cornice is proposed to be an off-white color that matches the stone color of the lintel and jamb details. Black canopies provide cover for guests at the east and west entrances. Detailing of the brick includes recessed vertical bands as well as horizontal soldier courses that provide an added sense of depth to the façade. While preliminary signage is shown on the images provided, any final signage will need to be approved separately from this submittal.

We hope this letter provides all the information necessary for review by the respective boards and commission. If you have any questions, please feel free to contact me. Thank you for your consideration.

Thank you,



Ian Jones, RA
Senior Director



February 26, 2024

To Whom It May Concern:

Pursuant to the application for approval of Planning Commission (site plan and conditional zoning certificate), Historic Preservation Board (certificate of appropriateness) and Board of Zoning Appeals (variance) regarding the Event Center, please find the enclosed information requested.

The current owner of record for permanent parcel numbers 028-19A-21-397 (245-257 South Court Street) and 028-19A-21-252 / 028-19A-21-253 (226 S. Elmwood Avenue), Legacy Hotel of Medina LLC, wishes to demolish and clear all structures in order to construct a 78-room boutique hotel in addition to an event center and parking, all located upon these parcels.

While some of the buildings are within the Medina Historic District, they are not a historic landmark, not listed or eligible for the National Register of Historic Place and is not a National Historic Landmark or part of a National Landmark Historic District. The buildings are single-wythe concrete block construction and possesses no characteristics of historical value.

The parcel (245-257 S. Court Street) was purchased by Jason T. Stevenson via a Limited Warranty Deed from James Gerspacher for the amount of \$1,200,000 on September 8th, 2023. Jason T. Stevenson is the President and sole member of The Legacy Hotel of Medina LLC and has transferred his interest to this entity. The additional parcels (226 South Elmwood Avenue) were purchased by Legacy Hotel of Medina LLC on 12/29/23 via a Fiduciary Deed from Martin Marcellus Living Trust Agreement dated March 4, 2002 for the amount of \$500,000.

The proposed cost of the demolition is estimated to be \$168,000 for structures currently on this parcel.

The current fair market value for the properties are estimated to be the same as the total purchase price of \$1.7 Million dollars (\$1,700,000), as the property was sold from previous owners to Stevenson/Legacy Hotel of Medina LLC less than 6 months ago. Following demolition and subsequent construction of the proposed hotel and event center, the anticipated valuation of the parcel and structures will be negligibly different due to the construction of the structure and the configuration of the structure on the site limiting potential opportunities beyond the current general use.

Rehabilitation to restore the structure to a move-in ready condition would yield no greater income due to the existing limitations on the structure. While costs for a simple rehabilitation could easily reach \$1,000,000, the value and income generation of the property would stay nearly the same.

Due to the simplistic nature of the structure, it is conducive to auto, equipment, and outdoor adjacent retail such as the current auto parts store, a hardware, lawn and garden equipment, etc. We would not consider this the highest and best use for the properties and we believe reconfiguring the site to compliment the hotel with an event center and efficient parking is a much more effective and desirable use of the property. Other uses would not fit for various reasons: Office space is over abundant, retail & restaurant are more suited to primary streets, and light industrial typically requires more space and isn't the most appropriate use for the location.

If any additional information is requested, The Legacy Hotel of Medina LLC will provide information as available in order to obtain this approval. I can be reached at the information below.

Regards,



Jason T. Stevenson
President
The Legacy Hotel of Medina LLC

REF. NO.	DESCRIPTION	DATE

LEGACY HOTEL OF MEDINA
 LOCATED IN
 COUNTY OF MEDINA
 CITY OF MEDINA

CUNNINGHAM & ASSOCIATES, INC.
 CIVIL ENGINEERING and SURVEYING
 203 W. LIBERTY ST. MEDINA, OHIO 44226 330-725-5980

EXISTING CONDITIONS PLAN

DRAWN BY: CAH
 DATE: 02/23/2024
 CHECKED BY: _____
 DATE: _____

PROJECT No.
 22-137

ACAD FILE No.
 M:\...22-137 SITE

SCALE: PLAN- 1"=20'
 PROFILE-Horz.
 Vert.

SHEET NO.
1 / **2**

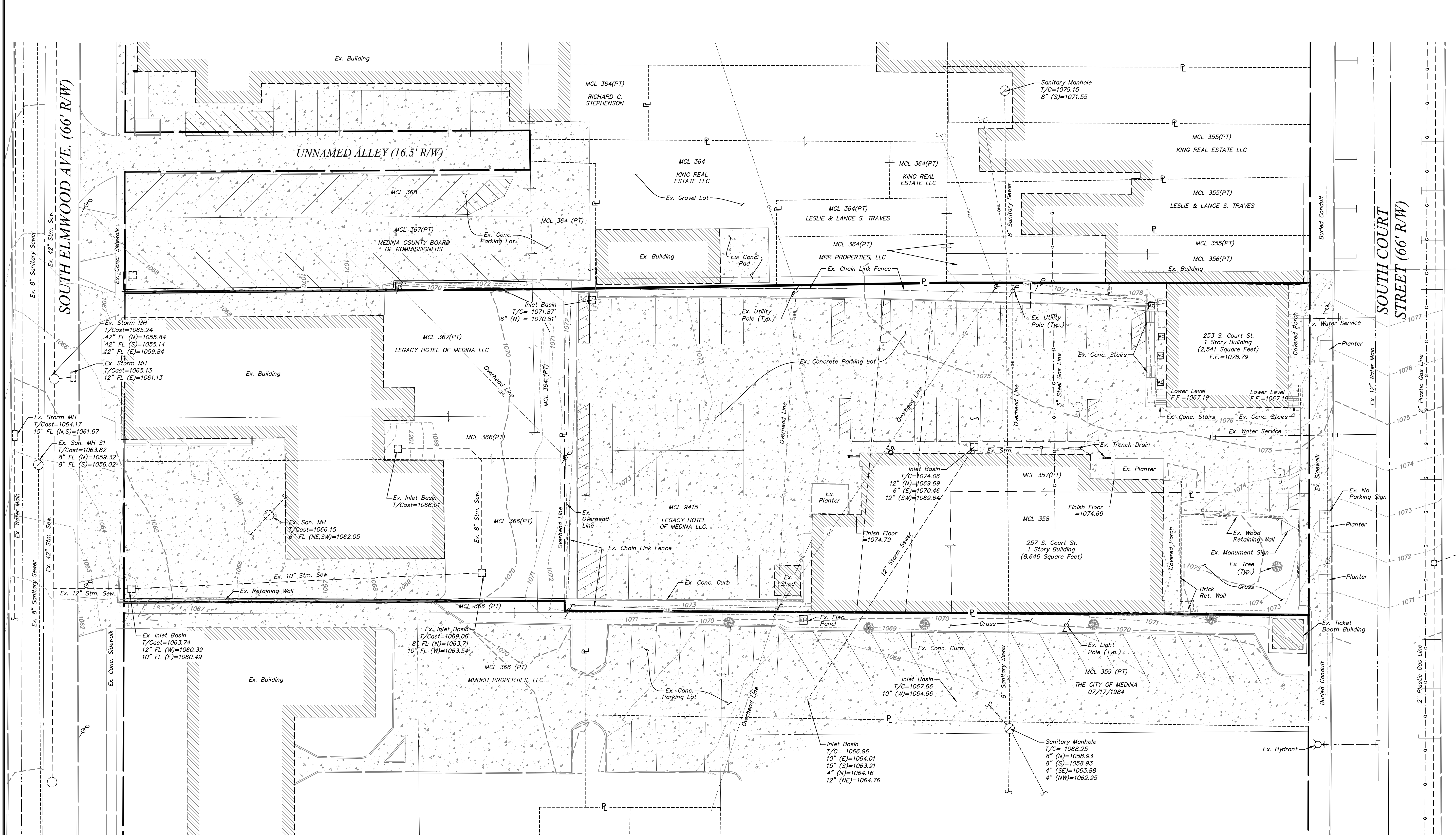

LEGEND

- | | | | |
|-----|-----------------------|---|---------------------------|
| --- | EX. SANITARY SEWER | ○ | EX. LIGHT POLE |
| ○ | EX. SANITARY MANHOLE | □ | EX. POWER POLE |
| ○ | EX. STORM SEWER | □ | EX. AIR CONDITIONING UNIT |
| ○ | EX. STORM MANHOLE | — | EX. OVERHEAD LINE |
| □ | EX. 2-2-B INLET BASIN | — | EX. SIGN |
| — | EX. WATER MAIN | — | EX. CONTOUR |
| — | EX. HYDRANT ASSEMBLY | ○ | EX. TREE |
| — | EX. LINE VALVE | ○ | EX. CONCRETE PAVEMENT |
| — | EX. GAS LINE | | |

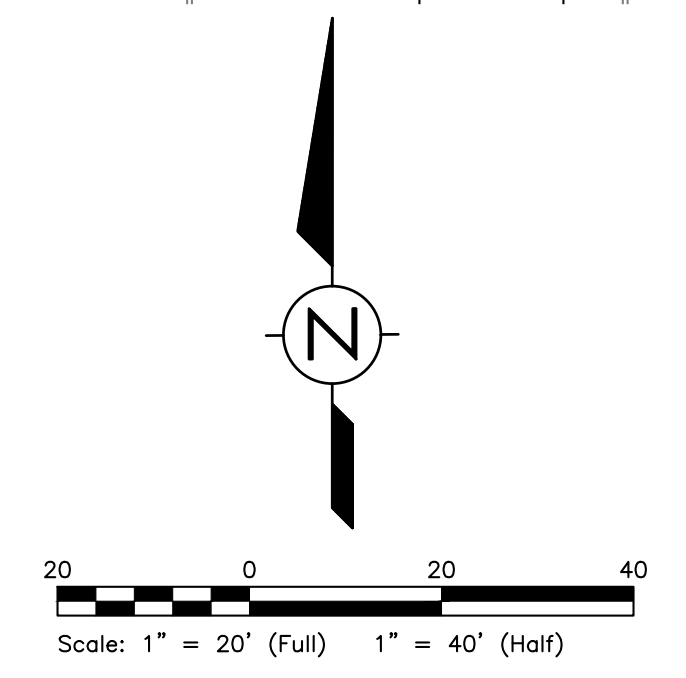

X:\Info_Folders\2022\22-137 Drawings\Improvement Plans\22-137 SITE EX.dwg, 2/26/2024 12:03 PM, A:\cadd3

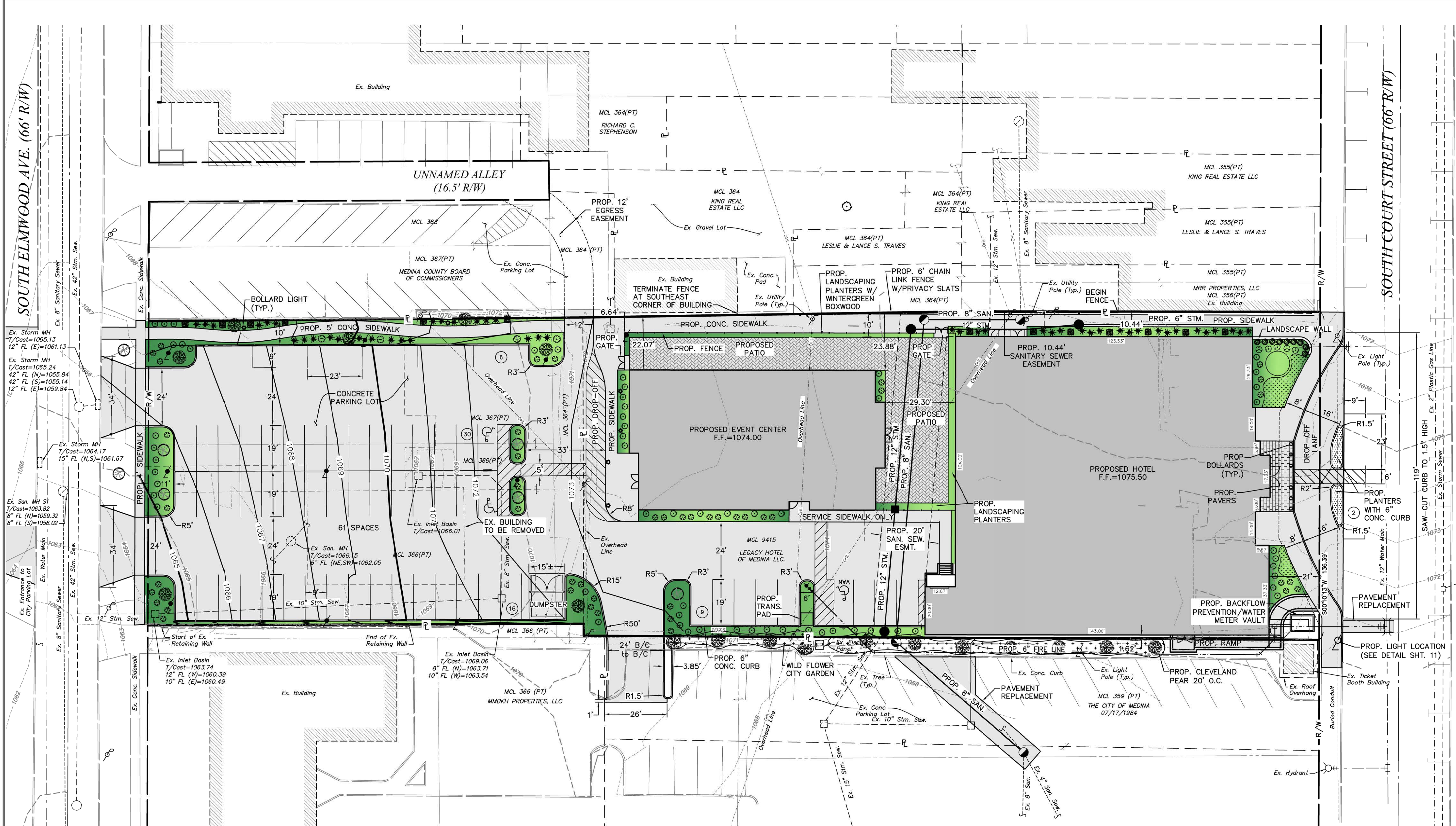

DATE	DESCRIPTION	BY

LEGACY HOTEL OF MEDINA
 LOCATED IN
 COUNTY OF MEDINA
CUNNINGHAM & ASSOCIATES, INC.
 CIVIL ENGINEERING and SURVEYING
 203 W. LIBERTY ST. MEDINA, OHIO 44226 330-725-5980

PRELIMINARY SITE PLAN

DRAWN BY: CAH
 DATE: 03/05/2024
 CHECKED BY:
 DATE:
 PROJECT No.
 22-137
 ACAD FILE No.
 M:\122-137 SITE

SCALE: PLAN- 1"=20'
 PROFILE-Horz.
 Vert.
 SHEET NO.
2 / **2**

LEGEND

	EX. HYDRANT ASSEMBLY		EX. SIGN
	EX. LIGHT POLE		PROP. TREE
	EX. POWER POLE		EX. CONCRETE PAVEMENT
	PROP. LIGHT POLE		PROP. CONCRETE PAVEMENT
	EX. OVERHEAD LINE		

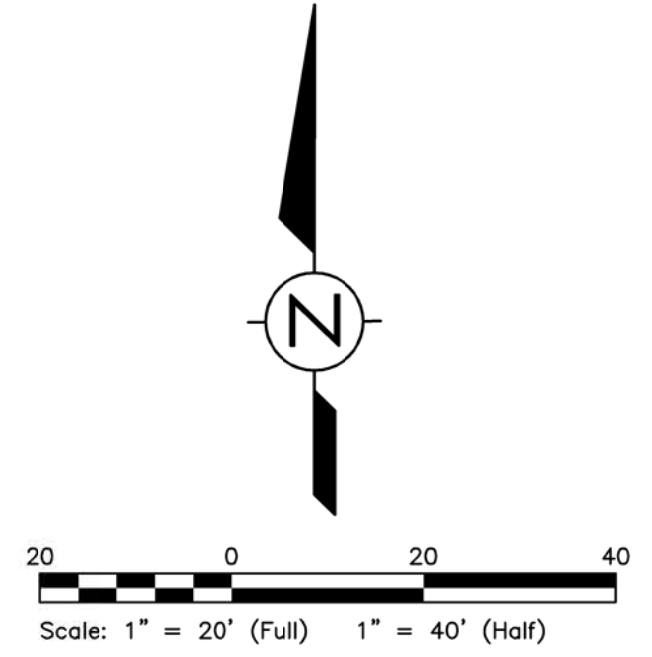

SOUTH ELMWOOD AVE. (66' R/W)

SOUTH COURT STREET (66' R/W)

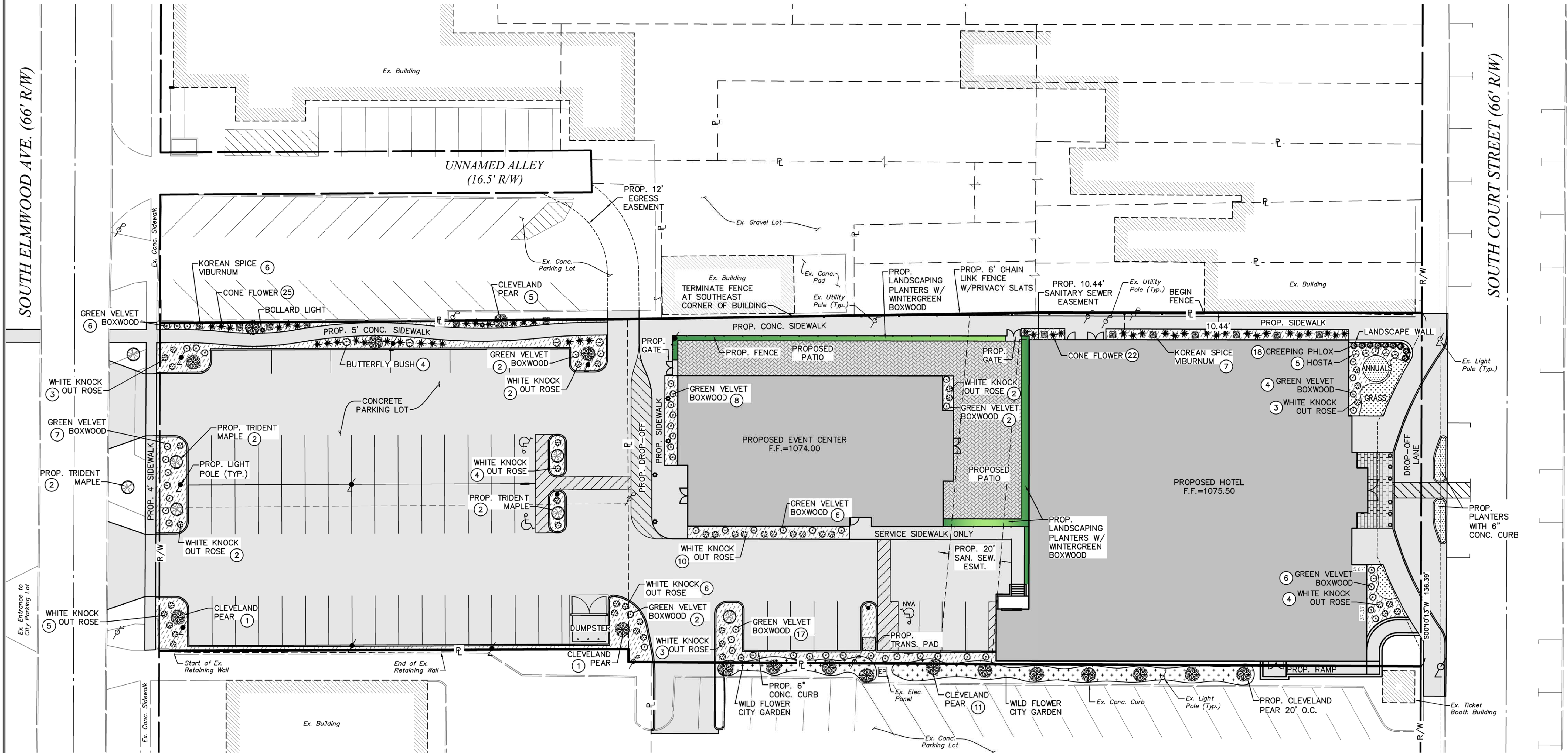

REVISIONS	DESCRIPTION	DATE

LEGACY HOTEL OF MEDINA
 LOCATED IN
 COUNTY OF MEDINA
 CITY OF MEDINA

CUNNINGHAM & ASSOCIATES, INC.
 CIVIL ENGINEERING and SURVEYING
 203 W. LIBERTY ST. MEDINA, OHIO 44226 330-725-5980

LANDSCAPE PLAN

DRAWN BY: CAH
 DATE: 03/05/2024
 CHECKED BY: _____
 DATE: _____
 PROJECT No. 22-137
 ACAD FILE No. M.C. 122-137 SITE LS

SCALE: PLAN- 1"=20'
 PROFILE-Horz. Vert.
 SHEET NO. 1/1

PLANT MATERIALS LIST			
QTY.	COMMON NAME	BOTANICAL NAME	SIZE
DECIDUOUS TREES			
8	TRIDENT MAPLE	<i>Acer buergerianum</i>	6'-7'
18	CLEVELAND PEAR	<i>Pyrus</i>	6'-7'
FLOWERING AND EVERGREEN SHRUBS			
80	WINTERGREEN BOXWOOD	<i>Buxus sinica var. insularis 'Wintergreen'</i>	12"
59	GREEN VELVET BOXWOOD	<i>Buxus koreana 'Green Velvet'</i>	12"
44	WHITE KNOCK OUT ROSE	<i>Rosa x 'RADwhite'</i>	12"
13	KOREAN SPICE VIBURNUM	<i>Viburnum carlesii</i>	12"
4	BUTTERFLY BUSH	<i>Buddleja davidii</i>	12"
PERENNIALS			
18	CREeping PHLOX	<i>Phlox subulata-white and pink</i>	6"
47	CONE FLOWER	<i>Echinacea purpurea</i>	8"-12"
5	HOSTA	<i>Fortunei 'aureomarginata'</i>	8"-12"
ANNUALS			
72	FLOWERING ANNUALS	Daylily, Red Impatiens, Coreopsis, Sweet williams, Aster, Geraniums	12"

GENERAL NOTES - PLANTING

- EACH CONTRACTOR IS TO VERIFY WITH OWNER AND UTILITY COMPANIES THE LOCATIONS OF ALL UTILITIES PRIOR TO CONSTRUCTION, TO DETERMINE IN THE FIELD THE ACTUAL LOCATIONS AND ELEVATIONS OF ALL EXISTING UTILITIES, WHETHER SHOWN ON THE PLANS OR NOT. THE CONTRACTOR SHALL CALL UTILITY PROTECTION SERVICE 72 HOURS PRIOR TO CONSTRUCTION.
- EXAMINE FINISH SURFACE, GRADES, TOPSOIL QUALITY AND DEPTH. DO NOT START ANY WORK UNTIL UNSATISFACTORY CONDITIONS HAVE BEEN CORRECTED. VERIFY LIMITS OF WORK BEFORE STARTING.
- CONTRACTOR RESPONSIBLE FOR COST OF REPAIRS TO EXISTING SITE CONDITIONS WHEN DAMAGED BY CONTRACTOR. REPAIR TO THE SATISFACTION OF THE OWNER.
- ALL PLANT MASSES TO BE CONTAINED WITHIN 3" DEEP HARDWOOD BARK MULCH BED.
- CONTRACTOR SHALL MAINTAIN POSITIVE DRAINAGE IN LAWN AREAS.
- FINE GRADE LAWN AREAS TO PROVIDE A SMOOTH AND CONTINUAL GRADE FREE OF IRREGULARITIES OR DEPRESSIONS.
- CONTRACTOR SHALL SEED OR SOD ALL AREAS DISTURBED DURING CONSTRUCTION, SEE PLAN.
- ALL PLANTS SHALL MEET OR EXCEED STANDARDS SET IN THE U.S.A. STANDARD FOR NURSERY STOCK.
- ALL PLANTING OPERATIONS SHALL ADHERE TO THE AMERICAN ASSOCIATION OF NURSERYMEN STANDARDS.
- LANDSCAPING MUST CONFORM TO THE CITY OF MEDINA PLANNING AND ZONING CODE CHAPTER 1149.
- BACKFILL WITH TOPSOIL AS REQUIRED TO BRING FINISHED GRADE FLUSH WITH GRADE ADJACENT, INSURING POSITIVE DRAINAGE OVER ALL SURFACE.
- LAWN AREA, FILL WITH TOPSOIL, MINIMUM DEPTH SHALL BE 6". MEET ADJACENT SURFACES FLUSH. MOUND TO PROVIDE POSITIVE DRAINAGE ACROSS ALL SURFACES.
- LANDSCAPE AREA, FILL WITH TOPSOIL, MINIMUM DEPTH SHALL BE 24". MEET ADJACENT SURFACES FLUSH. MOUND TO PROVIDE POSITIVE DRAINAGE ACROSS ALL SURFACES.

LEGEND

- EX. LIGHT POLE
- EX. POWER POLE
- EX. SIGN
- BOLLARD LIGHT
- TRIDENT MAPLE
- CLEVELAND PEAR
- PROPOSED WILD FLOWER GARDEN
- WHITE KNOCK OUT ROSE
- GREEN VELVET BOXWOOD
- BUTTERFLY BUSH
- KOREAN SPICE VIBURNUM
- CONE FLOWER
- PROPOSED GROUND COVER
- PROPOSED CONCRETE PAVEMENT

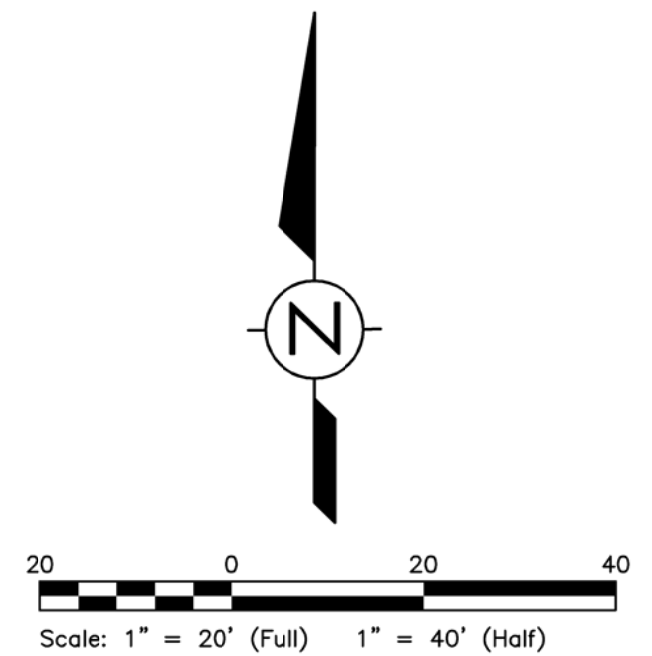

Mounting Height									
Symbol	Label	QTY	Manufacturer	Catalog	Description	Number Lamps	Lamp Output	Input Power	Notes
○	B1	15	KIM LIGHTING	PA7R-NU3-12L-010-4K7	BOLLARD @ 4ft	1	806	14.08	4' Mounting Height
○	P3	2	ARCHITECTURAL AREA LIGHTING	PROS-Y3-2040	PROVIDENCE SMALL - 15ft Post Top Light Fixture with Type III Distribution	1	1830	25.1	15' Mounting Height
○	P4	8	ARCHITECTURAL AREA LIGHTING	PROS-Y4W-3040	PROVIDENCE SMALL - 15ft Post Top Light Fixture with Type IV Distribution	1	2988	43	15' Mounting Height
○	P5	7	ARCHITECTURAL AREA LIGHTING	PROS-Y5-3040	PROVIDENCE SMALL - 15ft Post Top Light Fixture with Type V Distribution	1	2893	43.2	15' Mounting Height

Statistics						
Symbol	Max	Avg	Min	Max/Min	Avg/Min	Description
+	1.6 fc	0.6 fc	0.2 fc	8.0:1	3.0:1	Parking Lot

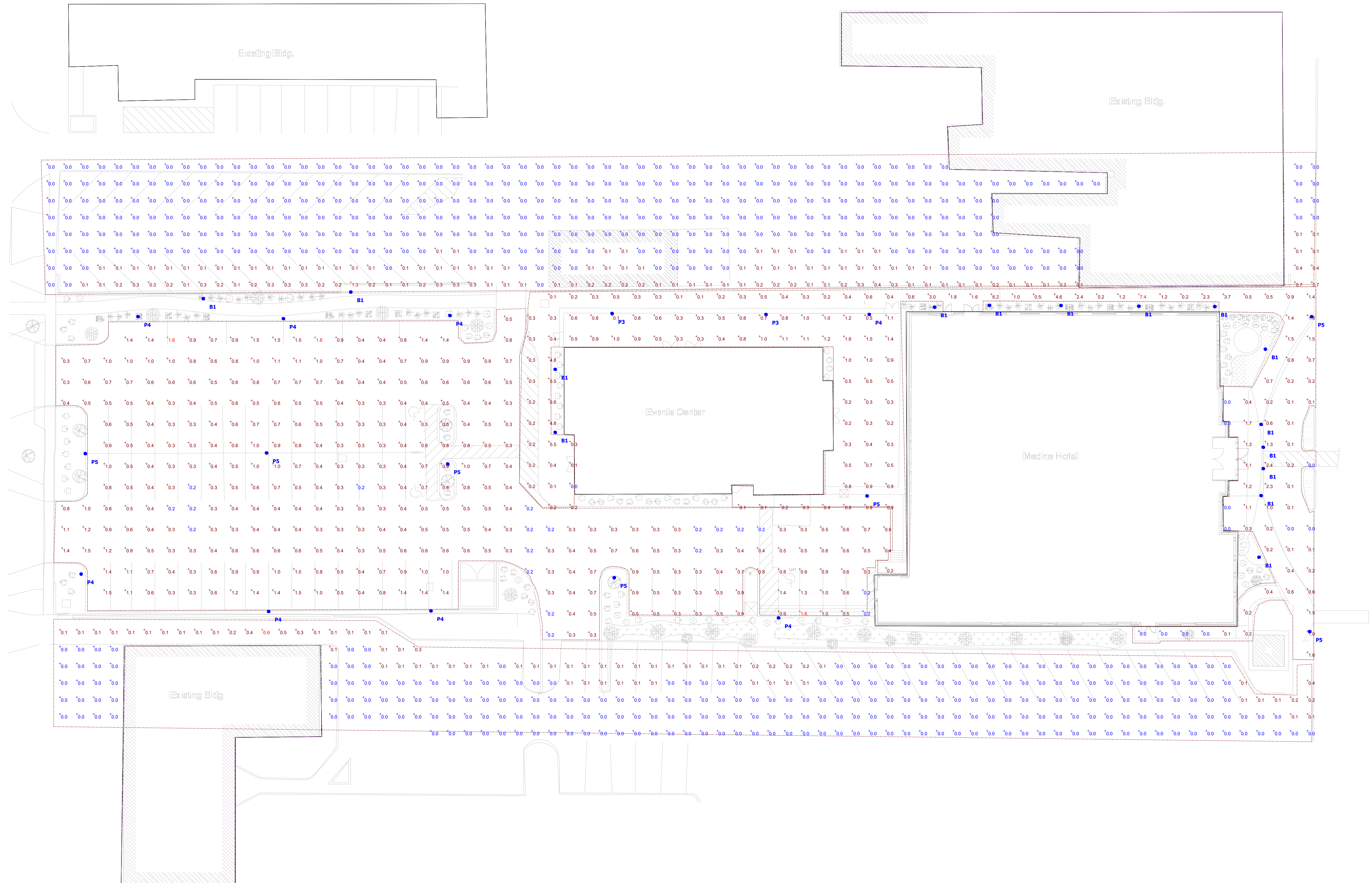

Plan View
Scale - 1" = 25ft

PHOTOMETRIC SITE PLAN
 LEGACY OF MEDINA HOTEL
 257 S COURT ST.
 MEDINA, OH 44256

Designer
 Date 03/11/2024
 Scale 1"=25'
 Project No. 14423
 Summary

DATE:	LOCATION:
TYPE:	PROJECT:
CATALOG #:	

PROVIDENCE®

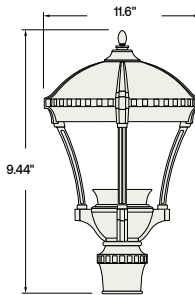

	WEIGHT	EPA
PROS	9 lbs / 4 kg	46

FEATURES

- Reliable, uniform, glare free illumination
- Types II, III, IV and V distributions
- 3000K, 4000K, 5000K CCT
- 0-10V dimming ready
- Integral surge suppression
- 15 standard powder coat finishes
- Upgrade Kits



3000K and warmer CCTs only

SPECIFICATIONS

CONSTRUCTION

- All housing components aluminum 360 alloy, sealed with continuous silicone rubber gaskets
- All internal and external hardware is stainless steel
- Finish: fade and abrasion resistant, electrostatically applied, thermally cured, triglycidal isocyanurate (TGIC) polyester powdercoat
- Optical bezel finish is match the luminaire housing

LED/OPTICS

- LEDs are mounted to a metal printed circuit board assembly (MCPCB) with a uniform conformal coating over the panel surface and electrical features
- Cartridge is easily disassembled to replace components. Optics are held in place without the use of adhesives
- Molded silicone gasket ensures a weather-proof seal around each individual LED
- Features revolutionary individual LED optical control based on high performance TIR optical designs
- House Side Shield is available on Standard and Clear Lens options except any Type 5 distribution. House Side Shield is not available for any distribution using a Diffused Lens

INSTALLATION

- Fixtures must be grounded in accordance with national, state and/or local electrical codes. Failure to do so may result in serious personal injury

ELECTRICAL

- Luminaires have integral surge protection, UL recognized and have a surge current rating of 10,000 Amps using the industry standard 8/20uSec wave and surge rating of 372J
- Drivers are UL recognized with an inrush current maximum of <200 Amps maximum at 230VAC
- 100%-1% dimming range. Fixture will be wired for low voltage 0-10V dimming control
- Driver and surge suppressor are mounted to a prewired tray with quick disconnects that may be removed from the gear compartment

CONTROLS

- Photocell adapter shall include an internal twist lock receptacle. Photocell by others.
- Egress adapter shall require an auxiliary 120 volt supply for operation of an integral MR16 lamp in the event of emergency. The lamp may be aimed and locked into position with an adjustment range of 15°-45°. Adapter shall have a socket that accepts miniature bi-pin MR16 lamps up to 50 watts, lamp by others

CERTIFICATIONS

- ETL listed under UL 1598 and CSA C22.2 No. 2500-08 for wet locations

WARRANTY

- 5 year warranty

Pavilion™

FEATURES

- IDA Dark Sky Compliant, No Up-light configuration
- Elegant form factor blended with Performance Optics
- Integral NEMA 3R Enclosure
- Dual receptacle power panel
- PA System capability
- Bluetooth® enabled RGBW accent



CONTROL TECHNOLOGY



SPECIFICATIONS

CONSTRUCTION

HOUSING:

- Castings are low copper aluminum alloy die-cast
- Gaskets are molded silicone to prevent harmful ingress to the lamp and driver compartments
- IP65 rated

SHAFT:

- Aluminum shaft(s) is .125" thick extruded aluminum 6061 alloy
- Concrete shaft(s) conforms to current specifications for "Portland Cement." ASTM C150, Type I or II. Aggregates shall meet current requirements of "Specifications for Concrete Aggregates," ASTM C33. Water shall be clean and free from deleterious amounts of silt, oil, acids, alkalis or organic materials. Wire for reinforcement shall conform to ASTM A185. Steel for lugs and plates shall conform to ASTM A36, or A283 grade D
- Concrete shaft(s) is medium sand-blasted with anti-graffiti sealer and material color shall be integral to the concrete mix
- Concrete shaft(s) is cured to allow for completion of the hydration process, and result in a 28 day compressive strength of not less than 4,500 psi
- Concrete shaft(s) is cast from fiberglass molds used to insure uniform parts. Mold parting lines may be slightly visible in finished parts

OPTICS

- LEDs mount to a metal printed circuit board assembly (MCPCB)
- Optical lenses are clear injection molded PMMA acrylic
- U0 configurations have an optically clear flat tempered glass lens, all other configurations have either an optically clear or high transmission diffused acrylic lens

INSTALLATION

- Aluminum shaft configurations will have four 3/8" x 10" x 2" zinc plated L-hook anchor bolts shall to be installed with an included template. Nuts and washers are provided to level and secure the mounting plate to the anchor bolts
- Aluminum shaft configurations will have a mounting plate and be able to be rotated 20° in either direction during installation for aiming adjustment
- Concrete shaft configurations will have four steel mounting tabs for installation on four 1/2" x 10" + 2" zinc electroplated L-hook anchor bolts. Each anchor bolt is supplied with two nuts, two washers, and a rigid pressed board template
- Concrete shaft configurations are palletized with adequate hold-downs to prevent load movement in transit
- Fixtures must be grounded in accordance with national, state and/or local electrical codes. Failure to do so may result in serious personal injury

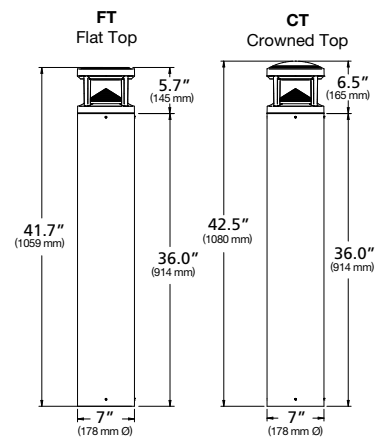

	Weight
PA7R	25.3 lbs / 11.5 kg

ELECTRICAL

- Universal voltage, 120 through 277V with a ±10% tolerance. Driver is Underwriters Laboratories listed
- High voltage configurations, 208-277, 347/480. Driver is Underwriters Laboratories listed
- "Thermal Shield", secondary side, thermistor provides protection for the sustainable life of LED module and electronic components
- Drivers are greater than a 0.9 power factor, less than 20% harmonic distortion, and be suitable for operation in -40°C to 40°C ambient environments
- Luminaire is capable of operating at 100% brightness in a 40°C environment. Both driver and optical array have integral thermal protection that will dim the luminaire upon detection of temperatures in excess of 85°C

(Specifications continued on page 3)



PROJECT INFORMATION

MEDINA HOTEL - EVENT CENTER
DATE: FEBRUARY 26, 2024
PROJECT NO. 14423

SHEET NAME
EXISTING PHOTOS -
SOUTH WEST CORNER
OF SITE

SHEET NO.
PH-01



PROJECT INFORMATION

MEDINA HOTEL - EVENT CENTER
DATE:
PROJECT NO. 14423

SHEET NAME

EXISTING PHOTOS -
WEST SIDE OF SITE

SHEET NO.

PH-02



Google

PROJECT INFORMATION

MEDINA HOTEL - EVENT CENTER
DATE: FEBRUARY 26, 2024
PROJECT NO. 14423

SHEET NAME

EXISTING PHOTOS -
WEST SIDE OF SITE

SHEET NO.

PH-03



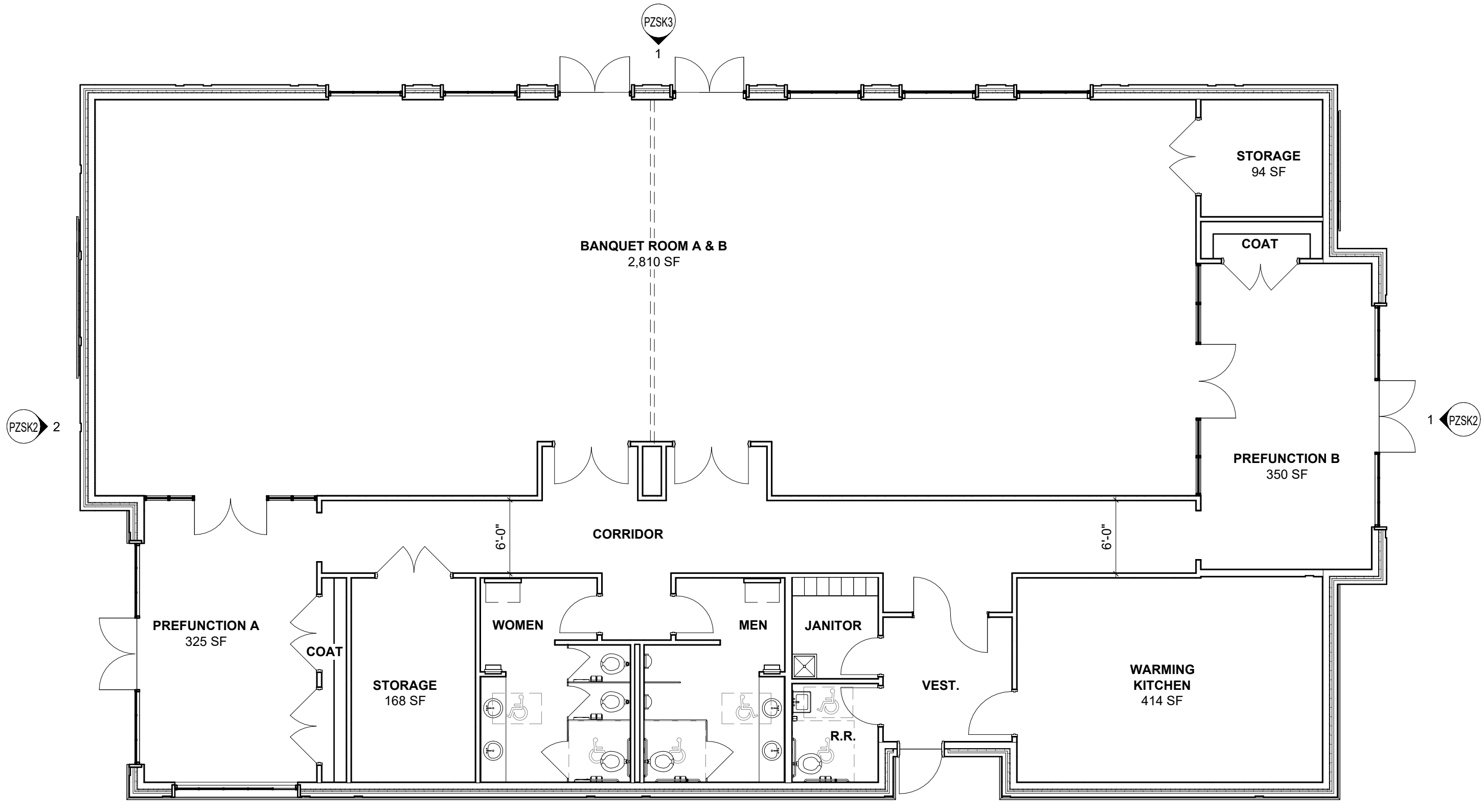

PZSK2 2

1 PZSK2

PZSK3 1

2 PZSK3

1 PLAN PRELIMINARY FLOOR PLAN
1/8" = 1'-0"

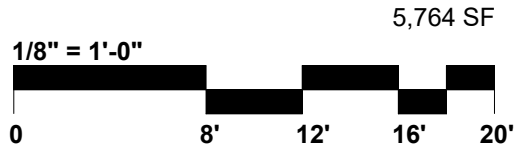
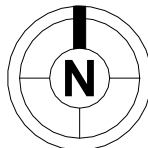

5,764 SF



PROJECT INFORMATION
 MEDINA HOTEL - EVENT CENTER
 DATE: FEBRUARY 26, 2024
 PROJECT NO. 14423

SHEET NAME SHEET NO.
 SCHEMATIC FLOOR PLAN PZSK1

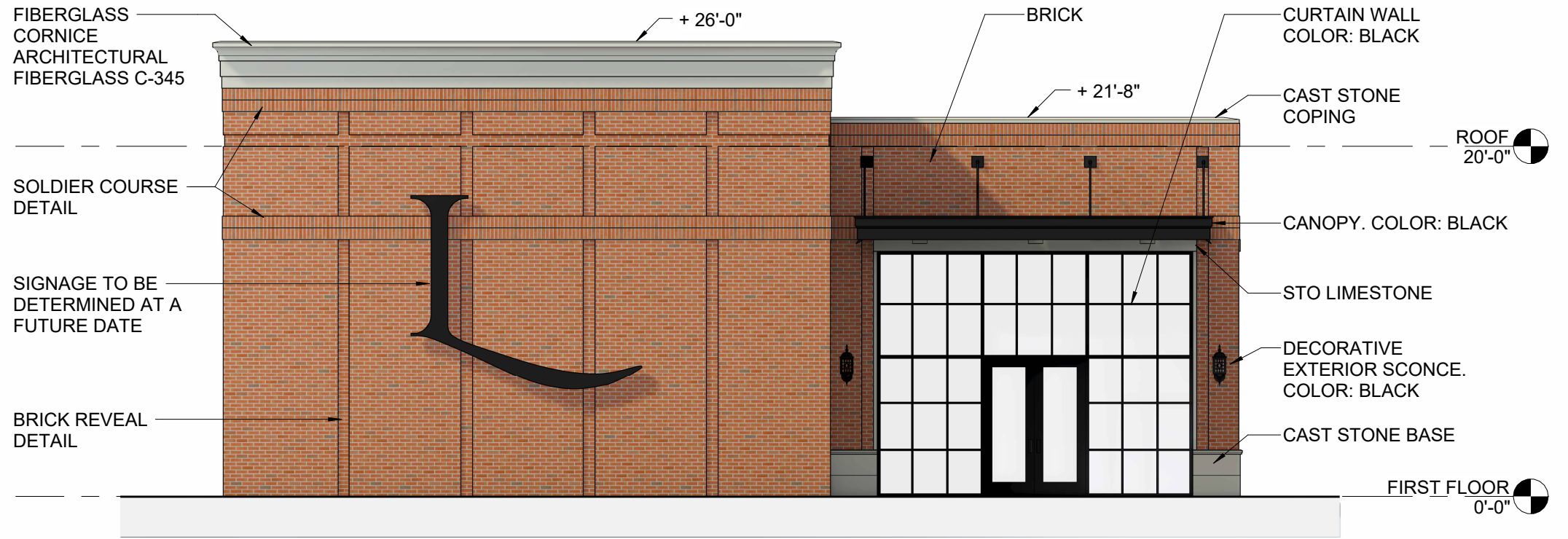

2 ELEVATION WEST - BANQUET "A" ENTRANCE
1/8" = 1'-0"

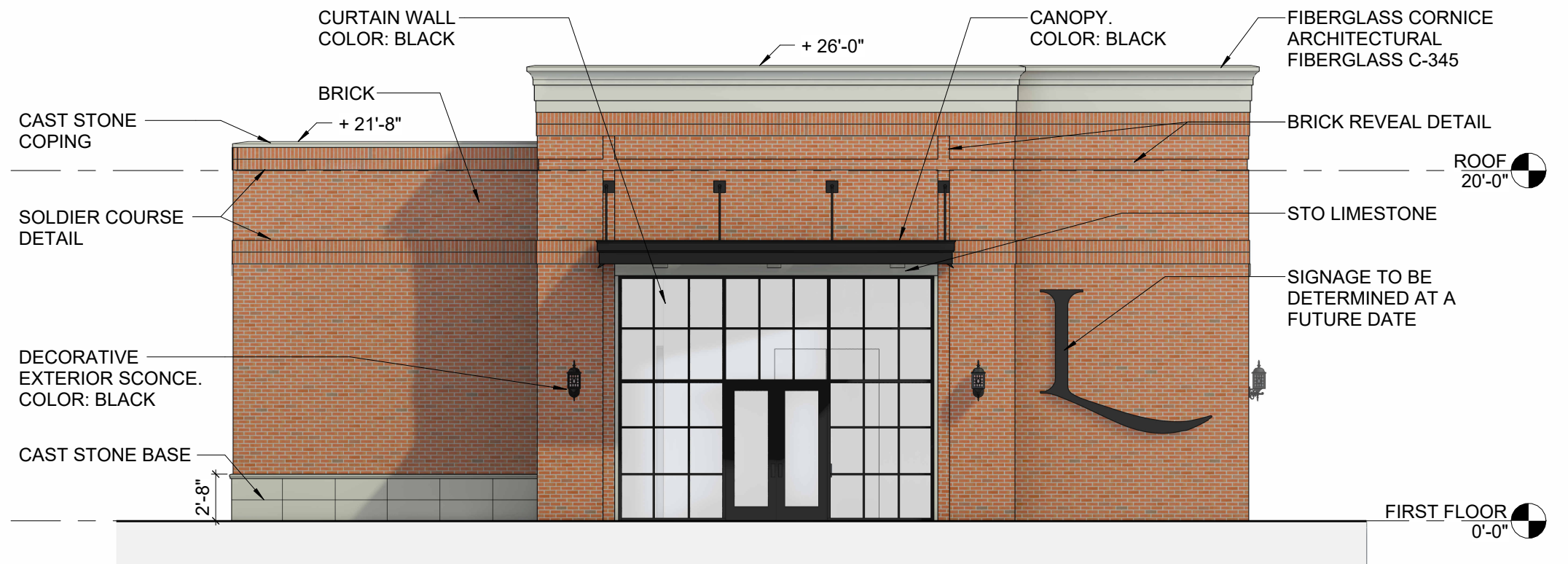

1 ELEVATION EAST - BANQUET "B" ENTRANCE
1/8" = 1'-0"

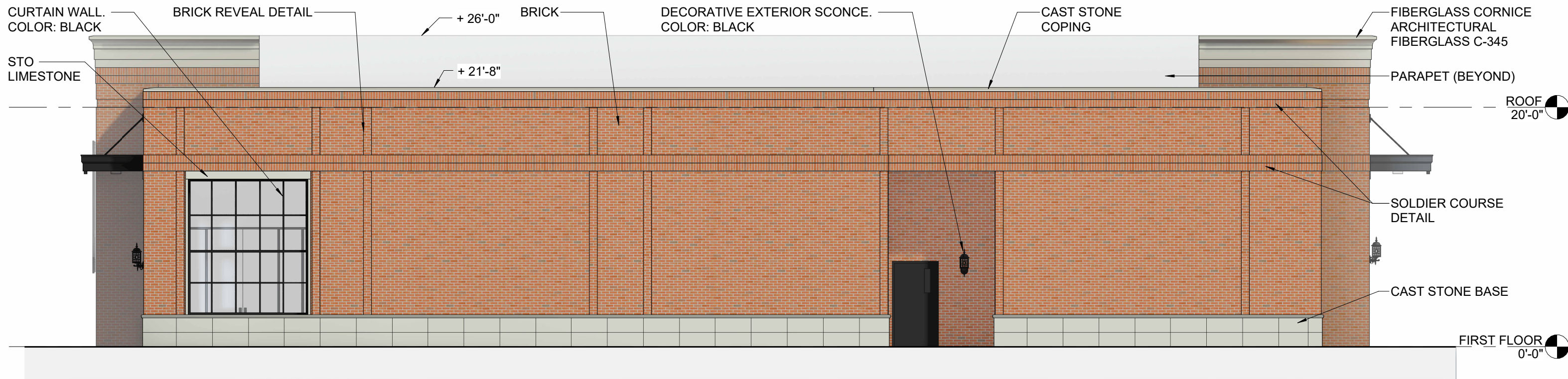

2 ELEVATION SOUTH
1/8" = 1'-0"



1 ELEVATION NORTH
1/8" = 1'-0"



PROJECT INFORMATION
 MEDINA HOTEL - EVENT CENTER
 DATE: FEBRUARY 26, 2024
 PROJECT NO. 14423

SHEET NAME	SHEET NO.
EXTERIOR ELEVATIONS	PZSK3

FIBERGLASS CORNICE - AMERICAN FIBERGLASS INC. C-345
 COLOR TO MATCH CAST STONE

C-345
 DEPTH: 1'-10 1/2"
 HEIGHT: 2'-7 7/8"

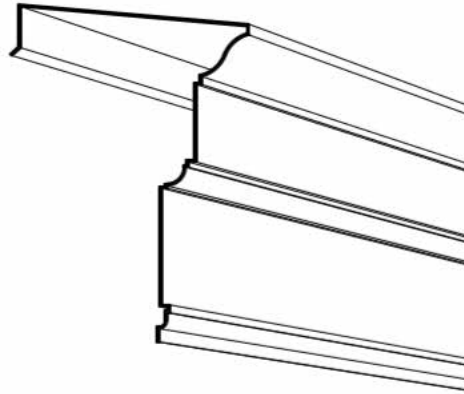

STO LIMESTONE FINISH AROUND
 BLACK CURTAIN WALL.

STO LIMESTONE FINISH



GLEN-GERY BRICK : OLDE DETROIT

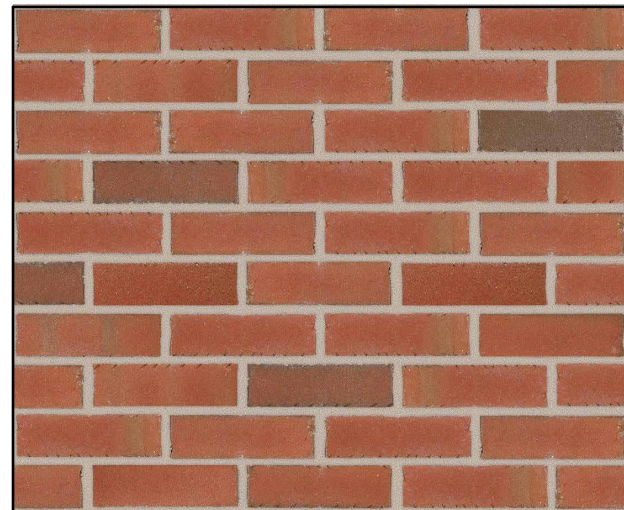

ARCHITECTURAL CAST STONE BASE, CUSTOM CASTSTONE.
 STONE SMOOTH FINISH CCS-112, CAP BNDCL-8S
 COLOR: SANDSTONE

STONE SIZE AND FINISH

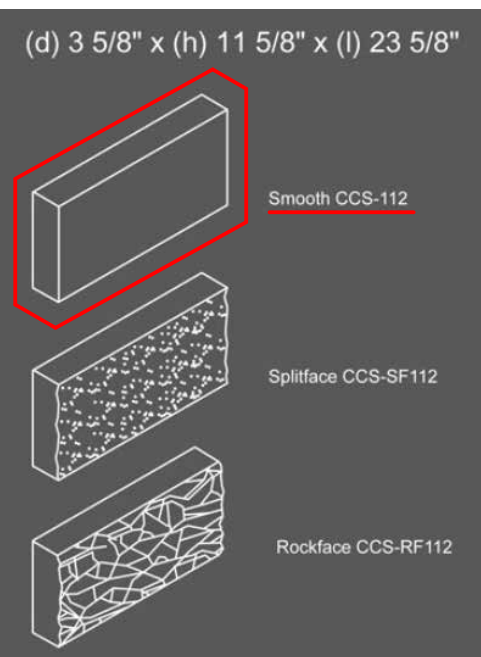

CAP PROFILE

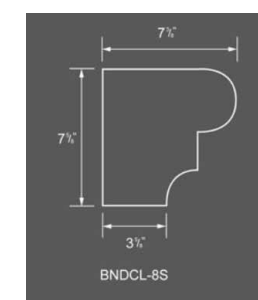

COLOR

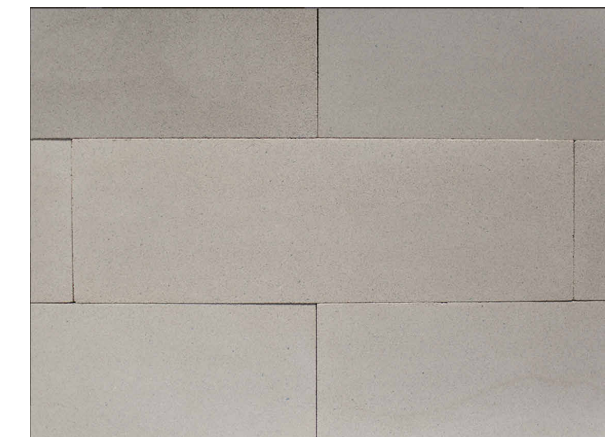

PROJECT INFORMATION

MEDINA HOTEL - EVENT CENTER
 DATE: FEBRUARY 26, 2024
 PROJECT NO. 14423

SHEET NAME
 EXTERIOR ELEVATION
 MATERIALS

SHEET NO.
 PZSK4





PROJECT INFORMATION

MEDINA HOTEL - EVENT CENTER
DATE: FEBRUARY 26, 2024
PROJECT NO. 14423

SHEET NAME

3D VIEW - NE CORNER

SHEET NO.

PZSK5





PROJECT INFORMATION

MEDINA HOTEL - EVENT CENTER
DATE: FEBRUARY 26, 2024
PROJECT NO. 14423



SHEET NAME
3D VIEW - NE CORNER
PATIO

SHEET NO.
PZSK6



PROJECT INFORMATION

MEDINA HOTEL - EVENT CENTER
DATE: FEBRUARY 26, 2024
PROJECT NO. 14423

SHEET NAME

3D VIEW - NORTH PATIO

SHEET NO.

PZSK7





PROJECT INFORMATION

MEDINA HOTEL - EVENT CENTER
DATE: FEBRUARY 26, 2024
PROJECT NO. 14423

SHEET NAME

3D VIEW - SW CORNER

SHEET NO.

PZSK8





7'-0" DUMPSTER ENCLOSURE.
BRICK TO MATCH HOTEL AND EVENT CENTER.
7'-0" BLACK GATE TO MATCH BLACK ACCENT
COLOR AT HOTEL AND EVENT CENTER.

PROJECT INFORMATION

MEDINA HOTEL - EVENT CENTER
DATE: MARCH 11, 2024
PROJECT NO. 14423

SHEET NAME

3D VIEW - NW CORNER

SHEET NO.

PZSK12





PROJECT INFORMATION

MEDINA HOTEL - EVENT CENTER
DATE: FEBRUARY 26, 2024
PROJECT NO. 14423

SHEET NAME

3D VIEW - SE CORNER

SHEET NO.

PZSK9





PROJECT INFORMATION

MEDINA HOTEL - EVENT CENTER
DATE: FEBRUARY 26, 2024
PROJECT NO. 14423



SHEET NAME

3D VIEW - NE CORNER AT
NIGHT

SHEET NO.

PZSK10



PROJECT INFORMATION

MEDINA HOTEL - EVENT CENTER
DATE: FEBRUARY 26, 2024
PROJECT NO. 14423



SHEET NAME

3D VIEW - SW CORNER
AT NIGHT

SHEET NO.

PZSK11



Architecture
Preservation
Graphics
Planning
Interior Design

620 East Smith Rd
Medina, Ohio
44256

330.723.6975
(phone)

330.723.7129
(fax)

March 13, 2024

Planning Commission, Historic Preservation Board, Board of Zoning Appeals
c/o, Andrew Dutton, Community Development Director
City of Medina
132 North Elmwood Street
Medina, Ohio 44256

Re: Event Center for Legacy Hotel of Medina
Case Nos. P24-09, H24-06, Z24-08,

Dear Board Members,

Rose Company has requested I review the above referenced project, the Event Center for the Legacy Hotel, relative to the impact the project may have on their property at 241 South Court Street and provide you with my thoughts. One of their main concerns is maintaining access to the back of 241 South Court from the south, which is across the hotel property. As a resident of the community, I expanded my assessment to also assess how the project as a whole might integrate into the community and as a result, developed the alternative site plan for the project which I have attached.

This alternative plan expands the scope of the project, but I think the affected parties will find the implementation of a site development similar to what I have sketched to be positive for all parties involved. As many of you are aware, I have lived in the community for over 60 years and have taken part in the preservation and renovation of the historic district since the early 1980's.

Back in 1992, we started working with Washington Properties (Rose Company) on the redevelopment of the Zeigler's building. As part of this project, we worked with Old Phoenix bank on cleaning up the area behind Zeigler's and creating a more direct access from the parking to the renovated building. As part of the work, the existing parking was redeveloped to make it flow better and a walkway was installed from the parking to a new entrance on the west side of the Zeigler's building. This created a more pleasant path, leading people from the parking through Towne Square Commons and out onto the square.

In 1995, Washington Properties started to redevelop the telephone exchange building, which is now Park Exchange. As with the Towne Square project, parking was a concern for the project and was typically cited by the community as to why people did not like shopping around the square. In response to the issue, we floated the idea of trying to develop a more unified parking layout for this area, similar to what had been accomplished for the Towne Square project. We noted that such a project would result in more parking overall and would provide for diversity of use for the parking throughout the day by people in the district. An entrance was developed that faced this parking area and an access way was created that leads people through the building, but unfortunately the idea of a unified parking area did not garner the support necessary to make it a reality. Much of the resistance was from property owners wanting to protect and limit the use of their individual parking spaces.

With the proposed Event Center for Legacy Hotel, the number of players that would

be directly impacted by a unified parking layout is reduced and the opportunity to really enhance the parking for the community substantially improves. The removal of the NAPA store makes the area available for developing a unified parking plan. In the plan we are proposing, the area for parking redevelopment expands north to include both the county parking lot and the parking area behind Park Exchange. Both of these lots have parking that is difficult to use and is not compliant with city standards.

Utilizing all of this space and reconfiguring the layout, we are able to create a single large lot that provides parking that is both compliant with the city standards and corrects some hazardous conditions associated with the existing layout. As an example, the drive directly behind Park Exchange, is wide enough for one way traffic, but sees traffic in both direction as well as services the parking along Park Exchange. In addition, by moving the event center to the south, we are able to revise the layout of the drives and improve general circulation from the Feckley parking lot on the south through the event center and into this new parking lot. This plan also allows access to the west side of 241 South Court, a prime concern of Rose Company, and access which has existed to service 241 South Court for as long as I can remember.

By shifting the event center south, it also improves the walkway from South Court through the block and to the parking on the west, enhancing the opportunity to bring more people into the district. With the location for the Event Center to the south, the walkway is more open along its length, only enclosed between two buildings for a short length. We have also moved the walkway further south where it goes through the new parking area. In this proposed location, the walkway more closely aligns with the city parking lot on the west side of Elmwood. The addition of a crosswalk here, similar to what is found on the square, will enhance the connection between this underutilized parking area and the square.

By generating a more unified parking area on the west side of the block, this will enhance the appearance of the area and will create more activity for the merchants and potentially allow them to redevelop the backs of their buildings, similar to what has happened along the alley behind Towne Square Commons.

In summary, I think an opportunity exists here to make a significant improvement to the development of the historic district. This unified parking area will enhance access to all the property owners in the area. It brings with it easier access to the city's existing parking lot on the west side of Elmwood Ave., improves the availability of parking for not only the district, but also the Event Center, enhances the appearance of this area, and opens up the opportunity for more redevelopment of other existing buildings in the area, especially on the back side of buildings as they address this new parking lot.

Respectfully Submitted,

Anthony J. Cerny
Architectural Design Studios, Inc.

cc Jason Stevenson
Joe Moffa
Ian Jones

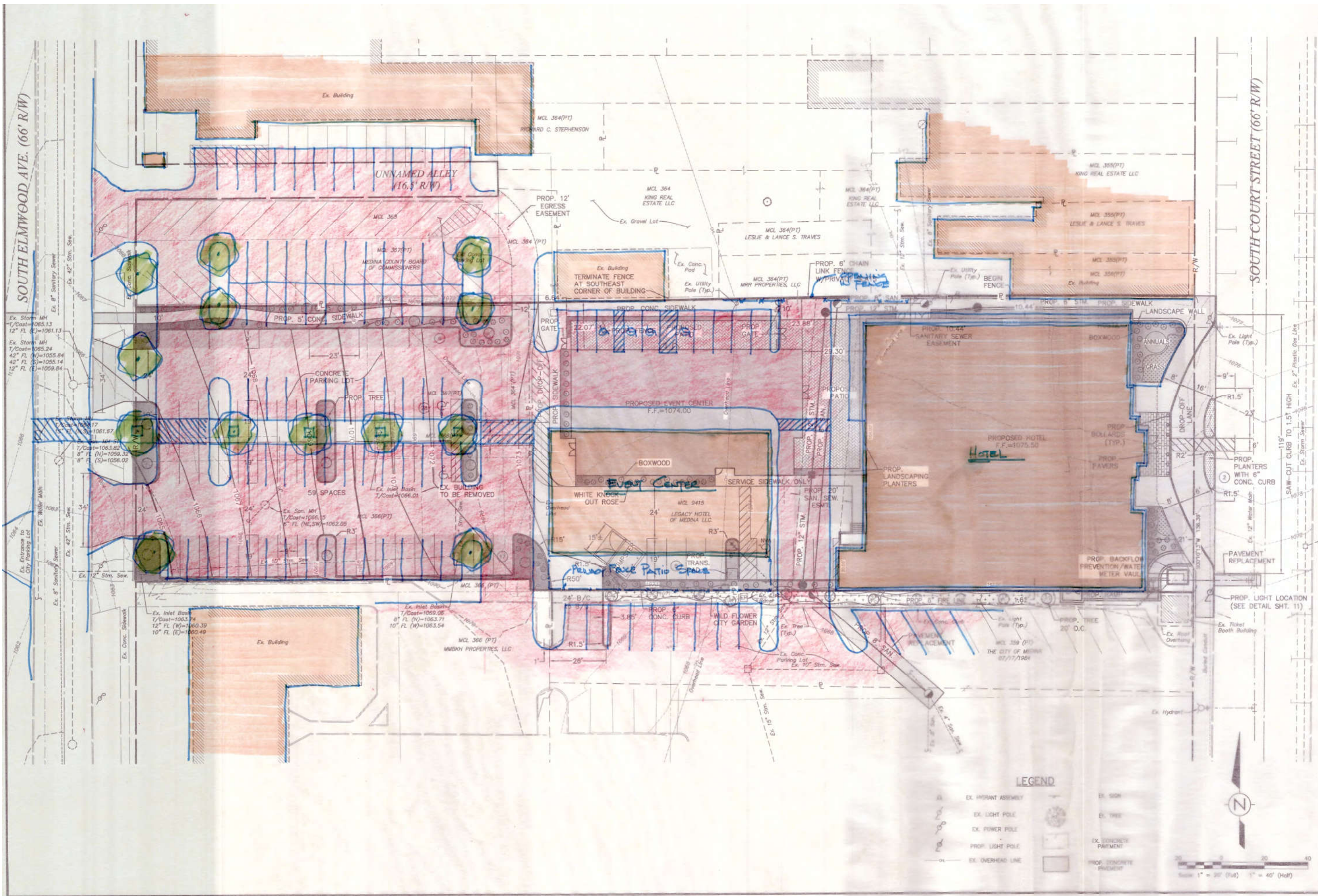

REVISIONS	DATE	DESCRIPTION

LEGACY HOTEL OF MEDINA
 LOCATED IN
 CITY OF MEDINA
CUNNINGHAM & ASSOCIATES, INC.
 CIVIL ENGINEERING and SURVEYING
 203 W. LIBERTY ST. MEDINA, OHIO 44226 330-725-5980

PRELIMINARY SITE PLAN

DRAWN BY: CAH
 DATE: 02/23/2024
 CHECKED BY: _____
 DATE: _____
 PROJECT No. 22-137
 ACAD FILE No. MCL 22-137 SITE

SCALE PLAN: 1"=30'
 PROFILE-Horz: Vert.
 SHEET NO. 2/2

LEGEND

	EX. HYDRANT ASSEMBLY		EX. SIGN
	EX. LIGHT POLE		EX. TREE
	EX. POWER POLE		EX. CONCRETE PAVEMENT
	PROP. LIGHT POLE		PROP. CONCRETE PAVEMENT
	EX. OVERHEAD LINE		

Scale 1" = 30' (Full) 1" = 40' (Half)

Lance S. Traves, Owner – City of Medina Lots 355 & 365
President - Labyrinth Management Group, Inc.
239 South Court Street
Medina, Ohio 44256
l.traves@LMGweb.com,
Cell: 330-603-9234

VIA ELECTRONIC EMAIL

March 14, 2024

Mr. Andrew Dutton
Director
Community Development
City of Medina
132 North Elmwood Avenue
Medina, OH 44256

Board Members
Planning Commission
City of Medina
132 North Elmwood Ave.
Medina, OH 44256

Board Members
Board of Zoning Appeals
City of Medina
132 North Elmwood Ave.
Medina, OH 44256

**Re: COMMENTS OF LANCE TRAVES AND LABYRINTH MANAGEMENT GROUP, INC.
ON REVISED PRELIMINARY SITE PLAN FOR PROPOSED HOTEL AT 257 SOUTH
COURT IN MEDINA, OHIO (MEDINA CASE NO.s P24-09, H-24-09, Z24-8)**

Mr. Dutton/Board Members

As the owner of 239 South Court Street that is located approximately 25 feet north of the proposed Legacy Hotel (the Proposed Hotel) and also the President of Labyrinth Management Group, Inc. (LMG), a tenant at 239 South Court Street, I am submitting these important new comments on the proposed changes the Applicant has made to the previously approved site plan. My comments also are a follow-up to an information revised plan submitted to the Planning Commission and other Board by Architectural Design Studios, Inc. on behalf of a north adjacent property owner Rose Company (the Rose Plan). This last minute informational revised site plan is provided at Attachment 1.

To be clear to the Planning Commission and other Boards, as a nearby property owner, I support the revised site plan submitted by the Applicant with one (1) comment. This comment is provided below.

More importantly, I do not support the Rose Plan as this version would result in the taking of my property and other neighboring properties for a required Private Road and result in significant adverse impacts on the use and condition of my property and neighboring properties. Additional information and comments on the Rose Plan is also provided below.

1.0 Comments Related to Applicant Submitted Revise Site Plan.

In reviewing the revised site plan submitted by the Applicant, I support the plan that includes the elimination of the prior “fire gate” at the northeast side of the site. The City of Medina Fire Department has determined that the fire gate is not required and the revised site plan’s elimination of this fire access also provides the Proposed Hotel and Event Center an open courtyard and pedestrian area that I believe will be a benefit to Medina.

However, the revised site plan includes a “privacy fence” on the site plan drawing that is to be constructed of as a ‘chain-link-fence” with privacy slates. I believe this is in violation of Chapter 1149.05 of the City of Medina Code and, I believe, will require a variance (see below).

The prior Planning Commission approved site plan also included a chain-link-fence, however, the approved site plan noted the fence as “black-coated.” I believe a black coated chain-link-fence is more in keeping with the character of the Historic District and I would not object to the use of a black coated chain link fence. However, I believe this black-coated description must be noted on the approved site plan or as a condition of Variance approval for the use of a chain-link fence.

1149.05 LANDSCAPING AND SCREENING STANDARDS.

(d) Materials for Screening and Landscaping.

(1) Walls and Fences. When walls or fences are used to fulfill screening requirements, they shall be detailed on the plan. They are to be of weather-proof materials. This includes pressure treating or painting of lumber if it is not redwood or cedar and using aluminum or galvanized hardware. **Chain link fences with or without wooded or synthetic slat material shall not be permitted when used to satisfy screening requirements.**

2.0 Adverse Comments Related to Rose Company Informational Site Plan.

I reviewing the informational Rose Plan, I believe this plan is addressing comments the Rose Company and north adjacent property owner submitted at the BZA meeting held Tuesday March 12, 2024. These comments indicated that the Rose Company (and owner of the northeast adjacent property) claim to have a right of access for vehicles from their property to travel across the Proposed Hotel property to South Court Street.

However, I understand that a right of access is not contained in a legally described instrument. In fact, the current and historical described access has been reported to me (and I expect others in Medina) as simply being the result of the current north adjacent property owner removing a previously existing fence section. Whether or not this was done legally is still to be determined. More importantly, I believe the City of Medina and Planning Commission are not legally authorized to grant any site plan change that would significantly adversely impact numerous nearby businesses all for the sole benefit of a single property owner (that is Not the Applicant) that also has undocumented and unconfirmed claims of rights to access across the Proposed Hotel property.

As previously submitted to the Planning Commission and the City of Medina during the initial Proposed Hotel site plan approval (Case P-22-19) any northeast open (i.e., ungated) access road from the Proposed Hotel north through the adjacent properties will clearly meet the definition of a Private Road as it will also allow access for random guests and others from the Hotel to travel across 4 nearby properties. As such, under City of Medina Code the private Road will be required to meet Public Road construction requirements. **The construction of such a designed road will result in a Taking of Property and Use from myself and all the other affected properties.**

As discussed in my letter of adverse comments dated August 9, 2022 for the prior case on the Proposed Hotel, I believed that the Applicant does not have an easement for any hotel guests or staff vehicles to cross the Part of Lot 355 and Lot 365 that my building and vehicle parking includes or the other additional properties that vehicles will be required cross IF the access proposed by the Rose Plan is provided and creates a Private Road.

Furthermore, if the Rose Company and owner of the north adjacent property has an access issue with the Applicant, the Rose Company and owner of the north adjacent property owner should be required to obtain a legal judgement enforcing that access before any action on the part of the Planning Commission or the City of Medina is taken on any Rose Plan or subsequent revised Applicant site that includes the same Private Road access.

The revised site plan submitted by the Applicant has eliminated the northeast access road. Thereby, any and all adverse impacts from the Proposed Hotel to my property and the additional parking areas and properties behind the 239, 235, 233, 229, and 225 South Court Street addresses. We support the Applicants revised site plan as it eliminates our parking area safety issues by blocking future vehicle access and we believe provides for an improved Event Center layout with improved sidewalk connection from South Court to South Elmwood Street. We do not support and would have adverse impacts from the Rose Plan.

There have been numerous incidents where vehicles have LMG employee vehicles parked on our properties in the past. It is only reasonable to expect that IF a Private Road is essentially allowed these adverse impacts will only increase to my property and other property owners.

Finally, the adverse impacts to myself and the other property owners of any access that results from a Private Road that will require construction to Public Road standards must be clearly reported by the City of Medina to both the PCB and BZA. To remain silent is negligent, arbitrary and capricious.

Furthermore, the City of Medina is also obligated to advise the PCB and BZA that they are required by Ordinance and Ohio law to consider the adverse impacts of the Private Road in the Rose Plan on my property and the other property owners in the evaluation of the most recent revised site plan and any requested Variances that are directly linked to significant changes to the site plan. Again, the Rose Plan is based on undocumented rights of the Rose Company and north adjacent property owner. To advise otherwise would be unreasonable and inappropriate.

Therefore, prior to any consideration of the Rose Plan I believe the City of Medina must first detail the engineering and construction aspects that a Private Road that would travel across our properties. Only then could the significant adverse impacts of the Private Road on my property and the neighboring properties be identified and evaluated by the Planning Commission and BZA.

Closing

In closing, the facts and findings provided in this letter clearly indicate that the Applicant's most recent revised site plan is acceptable with potential minor changes. However, the proposed Rose Plan (Attachment 1) with the access road results in significant adverse impacts on nearby property owners. Therefore, those significant adverse impacts must be identified by the City of Medina and weighed by the PCB and BZA.

In my opinion, the facts also clearly result in the denial of any consideration of the Rose Plan for the Proposed Hotel.

If you have any questions, please contact me at 330-603-9234.

Lance Traves/LMG, Inc.

Respectfully submitted,

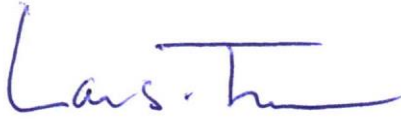
A handwritten signature in blue ink, appearing to read "Lance S. Traves". The signature is fluid and cursive, with a horizontal line extending from the top of the "L" across the "S" and "T".

Lance S. Traves, CHMM
Owner/President
Labyrinth Management Group, Inc.
239 South Court Street
Medina, Ohio 44256

Cc: the City of Medina - Historic Preservation Committee (via email)
Greg Huber, Law Director, City of Medina (via email)

Attachment 1: hand drawn Rose Plan for 257 S Court Street

Attachment 1: hand drawn Rose Plan for 257 S Court Street

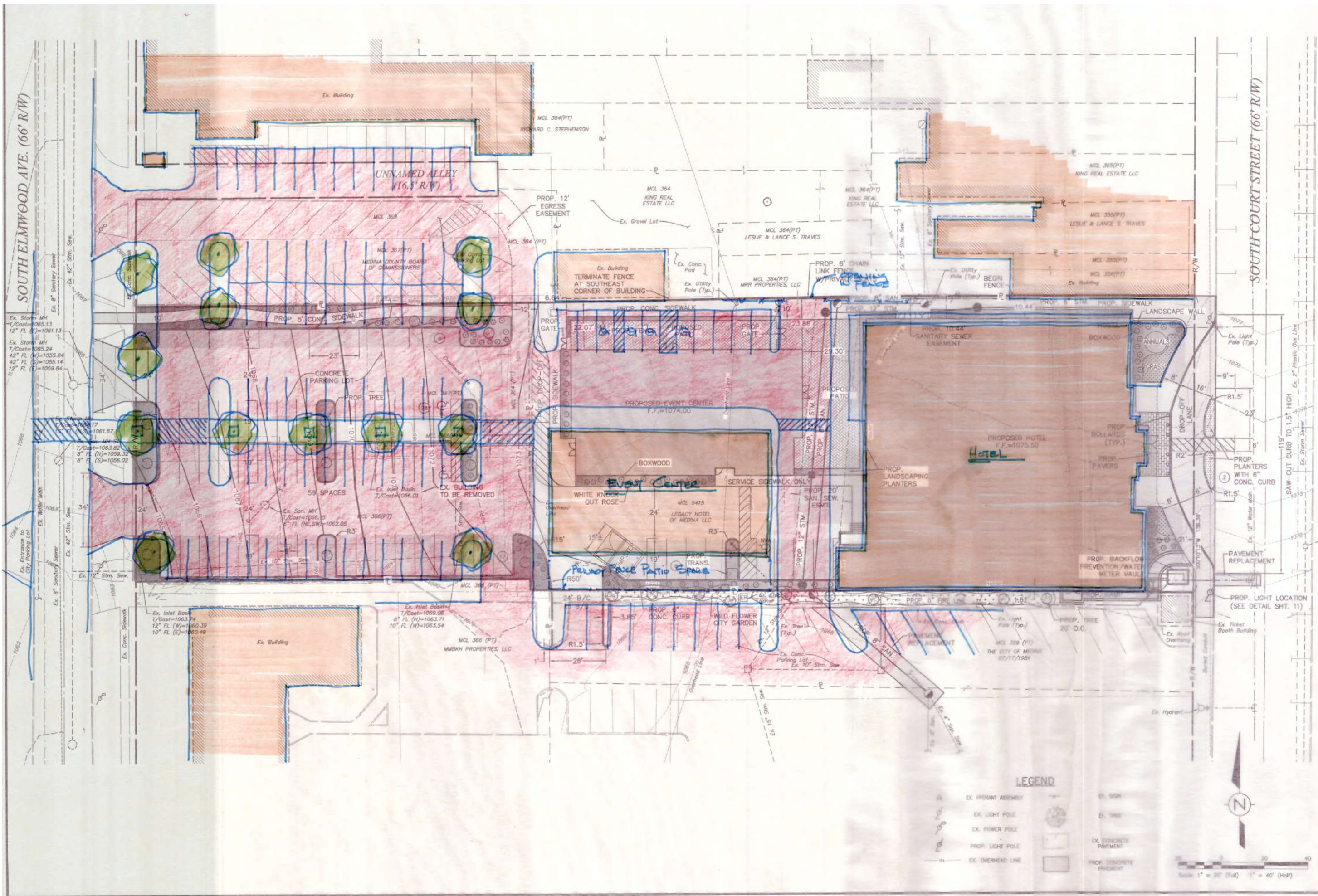

REVISIONS	DATE	DESCRIPTION

LEGACY HOTEL OF MEDINA
 LOCATED IN
 CITY OF MEDINA
CUNNINGHAM & ASSOCIATES, INC.
 CIVIL ENGINEERING and SURVEYING
 203 W. LIBERTY ST. MEDINA, OHIO 44226 330-725-5980

PRELIMINARY SITE PLAN

DRAWN BY: CAH
 DATE: 02/23/2024
 CHECKED BY:
 DATE:
 PROJECT No.
 22-137
 ACAD FILE No.
 MCL 122-137 SITE

SCALE PLAN: 1"=20'
 PROFILE-Horz.
 Vert.
 SHEET NO.
 2 / 2