

REQUESTS FOR COUNCIL ACTION/DISCUSSION

Finance Committee

- 21-129-6/28 – Budget Amendments
- 21-130-6/28 – Then & Now – Treasurer, State of Ohio
- 21-131-6/28 – Donation to Medina City – Do It Best Corp.
- 21-132-6/28 – Easement – Spring Grove Bridge Replacement
- 21-133-6/28 – Accept Donation to Police Department for Drone Operations
- 21-134-6/28 – Contract w/ FirstComm Communications – Municipal Court
- 21-135-6/28 – Amend Job Creation Grant JCG-18 – Kraft Werks Engineering
- 21-136-6/28 – Expenditure to Pavement Management Group for Pavement Mgmt. Program
- 21-137-6/28 – Preliminary Engineering Agreement – W. Smith Road, Phase 4
- 21-138-6/28 – MOU w/ Medina County – Water Service on SR 18
- 21-139-6/28 – Easements – Lindenwood Headwall Replacement – Job #1074
- 21-140-6/28 – Purchase (2) 108SD Conventional Chassis Plow Trucks – Streets
- 21-141-6/28 – Restoration of 10% Budget Cuts from 2020
- 21-142-6/28 – 2021 Annual Codification Update

6/28/21

OK RCA 21-136-6/28

Finance Only

City of Medina
Board of Control/Finance Committee Approval
Administrative Code: 141

- Department Heads can authorize expenditures up to \$1,500.00 (requisition)
- Board of Control authorizes expenditures from \$1,500.01 to \$15,000.00 (BOC form).
- Finance Committee authorizes expenditures from \$15,000.01 to \$25,000.00 (BOC form).
- Council authorizes expenditures/bids over \$25,000.00 (RCA form). Board of Control awards all bids, unless otherwise specified in authorizing ordinance. (Ord. 101-05)

Date: 6/22/2021 Department: Engineering

Amount: \$25,000.00 B.O.C. Approval Date: _____
(Finance Use Only)

Account Number: 108-0610-54411

Vendor: Pavement Management Group

Department Head/Authorized Signature: _____

Item/Description:

Provide a pavement management program, including software set up, network inventory,
condition assessment of all City streets, and providing a final report with condition mapping.

\$25,000

FINANCE COMMITTEE APPROVAL: (expenditures from \$15,000.01 to \$25,000.00)

Date Approved/Denied by Finance Committee: _____

Clerk of council Date to Finance: _____

- Please have all BOC items for the agenda to the Mayor's Office before 5 p.m. on Friday before the scheduled BOC meeting.
- Please have all Finance Committee items for the agenda to the Clerk of Council's Office before 5 p.m. on Tuesday before the scheduled Finance Committee meeting.

Thank you.

PMG

PAVEMENT MANAGEMENT GROUP

COMPLETE PAVEMENT MANAGEMENT SERVICES PROPOSAL

PREPARED FOR: THE CITY OF MEDINA, OH



The City Of
Medina
Ohio

COMPLETE PAVEMENT MANAGEMENT SERVICES PROPOSAL

April 27, 2021

ATTN: PATRICK PATTON
City Engineer
The City of Medina
132 N Elmwood Ave
Medina, OH 44256

SUBJECT: COMPLETE PAVEMENT MANAGEMENT SERVICES PROPOSAL

Dear Mr. Patton:

The following proposal outlines the scope of services from the Pavement Management Group (PMG) to provide the City of Medina with a complete pavement management program on your estimated 100 centerline mile street network.

Should you have any questions, please contact me to discuss at your convenience.

Respectfully,

PAVEMENT MANAGEMENT GROUP

Dominic Caminiti
General Manager
(614) 778-2375
Dominic@PavementManagementGroup.com



Contents

Section 1. Company Qualifications	3
Description and Location	3
Key Personnel.....	4
Notable Publications & Invited Talks.....	6
Partner Companies:.....	7
Recent Projects.....	7
Section 2. Scope of Services	8
The Pavement Management Blueprint from PMG	8
Commitment to Quality Data Collection.....	8
A. Project Kickoff Meeting.....	8
B. Pavement Management System and Set Up.....	8
C. Network Inventory with High-Definition Video	9
D. ASTM D6433 Condition Assessment	10
E. GIS Assignment and Condition Mapping.....	12
F. Final Project Deliverable	13
G. RoadInsights - Data Management, Consulting & Support	14
Section 3. Project Timeline.....	14
Section 4. Project Costs and Terms	15
Section 5. Future Project Consideration	Error! Bookmark not defined.
FISCAL YEAR 2022	Error! Bookmark not defined.
Section 6. Project Acceptance	15

Section 1. Company Qualifications

Description and Location

The Pavement Management Group (PMG) is a consulting firm specializing in providing professional pavement management services for public and private agencies throughout the United States.

The firm was initially founded by President and CEO James Golden III in 2011 under the name JG3 Consulting after a 14-year career managing and directing pavement management projects for a local engineering firm. The firm was recently re-branded to the Pavement Management Group (PMG) in January of 2017 to better serve our clients' needs and business growth model.

CPWG Engineering, Inc. is our partner and sister company with a 40% stake in the business. Our partnership provides complete pavement management and engineering services to our clients. Since its inception, one hundred percent of PMG's business operations have been spent working directly within the industry of pavement management.

What separates PMG from our competition is our expertise in industry-leading pavement and asset management systems (PMS), the standardized ASTM D6433 distress-based condition assessment, the Pavement Condition Index (PCI), extensive knowledge of pavement maintenance, preservation, and repair, our advancements in AI and cloud-based technology with our partner Roadata, Inc., and expertise in project planning to produce a turn-key pavement management solution for our clients. We fully understand how to utilize all system tables and tools within leading pavement and asset management systems to help our clients realize their goals.

PMG's official office headquarters are located at 579 Hebron Road, Heath, OH 43056. We also have three additional satellite locations, Tampa, FL, Oviedo, FL, and Branson, MO, with our fourth in process in Stanford, CA as our firm continues to grow to serve our Nation's pavement management needs.

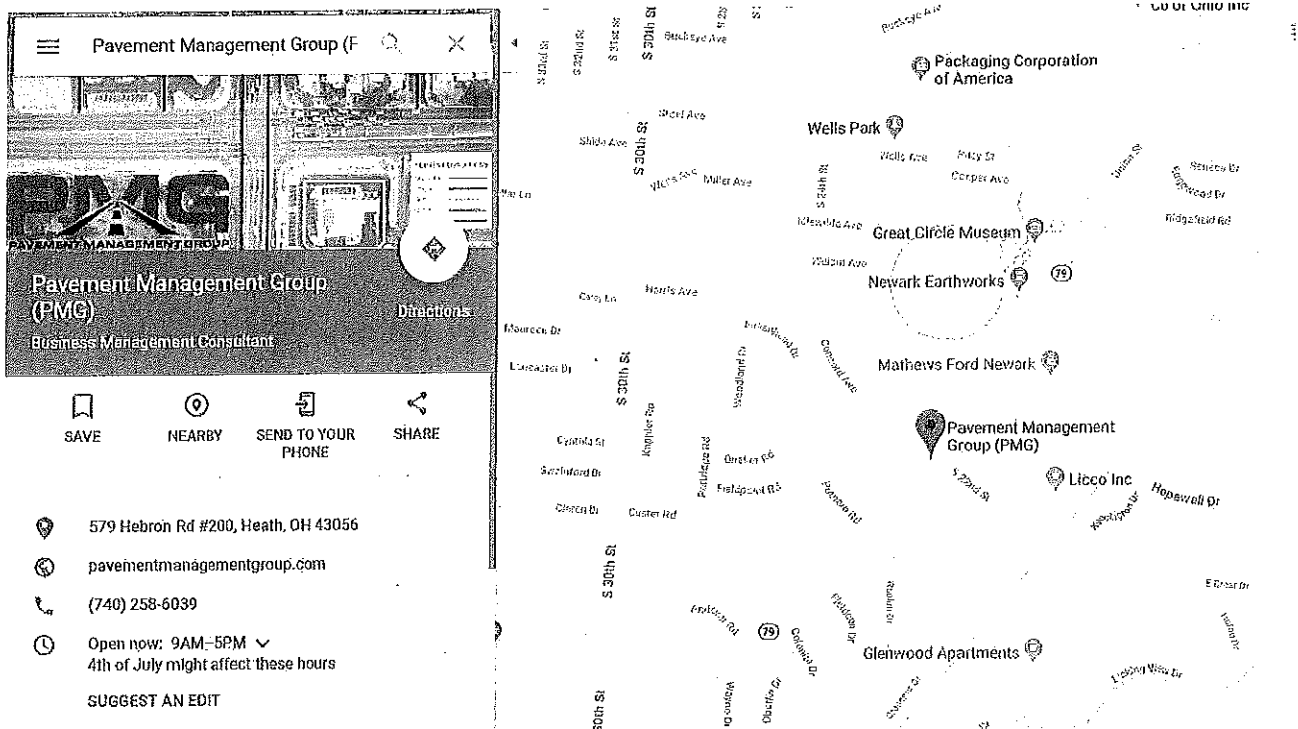

COMPLETE PAVEMENT MANAGEMENT SERVICES PROPOSAL

Key Personnel

Pavement Management Group LLC is a nationwide roadway condition assessment and consulting firm that is committed to the collection of quality distress data against the ASTM D6433 for use with optimized pavement/asset management systems. Our data and deliverables are relied upon by engineers, consultants, and municipalities nationwide for developing their long-term roadway project plans. James Golden, the firm's CEO, will manage and facilitate all aspects of the roadway condition assessment project and will provide our data-driven and map driven condition assessment deliverables directly to the client.



James Golden, CEO

James holds an associate degree in drafting design technology from the Central Ohio Technical College and a bachelor's degree in Information Technology from the University of Phoenix. He has been working directly within the engineering, and pavement management industry for over 22 years, with the first 12 working directly under a Civil P.E. and pavement management specific engineering consultancy as Chief Operating Officer. The remaining 10 have come as CEO and business owner, serving federal, state, and local agencies with their pavement management and roadway condition assessment needs. James has not only proven competency in ASTM D6433 condition assessment and advanced pavement management but has also successfully taught others as well. Certifications of completion from Colorado State University's Level I and II Pavement Management training as well as the Metropolitan Transportation Commission's Rater Certification Program.



COMPLETE PAVEMENT MANAGEMENT SERVICES PROPOSAL

Dominic Caminiti, General Manager

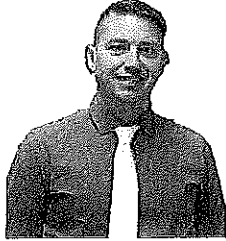

Mr. Caminiti has been working directly within the engineering, and pavement management industry for over 10 years while performing pavement management related services for municipal, federal and private agencies throughout the United States. To date, Mr. Caminiti has been directly responsible for over 75 successful initial and re-inspection pavement management-based projects, equating to over 75,000 ASTM D6433 and PCI based inspections.

Mr. Caminiti also acts as the General Manager for the Pavement Management Group, Providing client relations and support while assisting in inspections, production, and quality management tasks. Certifications of completion from Colorado State University's Level I and II Pavement Management training as well as the Metropolitan Transportation Commission's Rater Certification Program.



Additional Project Personnel:

Name	Role	Experience
Dillon Golden	ASTM Inspection Management	7 Years
Cory Joyce	GIS and Video Management	3 Years
Martin Ziegler	Video Capture	1 Year
Janet Golden	Office Management	30 Years

COMPLETE PAVEMENT MANAGEMENT SERVICES PROPOSAL

Notable Publications & Invited Talks

PMG's founder and CEO has provided the engineering, technology, and construction industry with a variety of published content pieces spanning from podcast guest spots, teachings, webinars articles. The following is a shortlist of PMG and James's most recently published content:

Webinar

PMG – The Pavement Management Blueprint
The PMG Approach to Pavement Management
December 16th, 2020
<https://youtu.be/ot0dOVxJDkY>

PPRA – Ahead of the Curve Webinar Series
Prioritizing Road Projects by Most Impact
August 30th, 2019
<https://youtu.be/ot0dOVxJDkY>

Podcast

ReThink IT
Intelligent Pavement Management with James Golden, CEO, PMG
July 20, 2020
<https://tinyurl.com/y6apx7lr>

The Construction Corner
Pavement Management with James Golden
April 6th, 2019
<https://tinyurl.com/y562sn88>

Publications

Tennessee Public Works Magazine
Maximizing your Pavement Program
July/August 2020
<https://tinyurl.com/y4vp79fl>

The Newark Advocate
CEO Spotlight: Heath's James Golden Aims for a Better Road Network through Planning
July 21, 2020
<https://tinyurl.com/y4nj7x2p>

Aces of Trades: Pavement Management Group's Golden is an Infrastructure Guru
April 6th, 2020
<https://tinyurl.com/y2kekz6x>

PPRA
Maintaining Roadway Network Conditions through an Extensive Crack Seal Program
June 24th, 2020
<https://roadresource.org/resources/74/success>

American City and County
How to Best Manage Resources and Road Networks
August 19th, 2019
<https://tinyurl.com/y2nt49sh>

COMPLETE PAVEMENT MANAGEMENT SERVICES PROPOSAL

Partner Companies:

CPWG Engineering, Inc

General Engineering Partner

CPWG is a 10% minority owner of PMG

<https://www.cpwgengineering.com/about-our-team-copy>

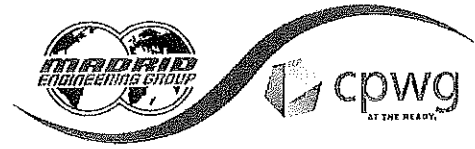

Roadata, Inc.

AI Development Partner

PMG is a 10% minority owner of Roadata

<https://www.roadata.co/>



Recent Projects

PMG is a recognized leader in the collection of quality data collection and providing turn-key pavement management programs throughout the Nation. The following is a noticeably short list of recent pavement management and condition assessment projects our firm has worked with throughout the United States. The size of these client's roadway networks ranges anywhere from 25 centerline miles to over 2,000 centerline miles in size! Large or small, near or far, PMG provides quality, objective, and standardized pavement management services to all in need.

The following projects and clients are all from the 2020 calendar year alone with a complete list of projects completed within the past three years is available upon request:

- City of Frostproof, FL
- City of Lady Lake, FL
- City of Longwood, FL
- City of Jersey Coty, NJ
- City of Hollister, MO
- AMATS, Akron, OH
- City of Aurora, OH
- City of Canton, OH
- City of Green, OH
- City of Grove City, OH
- City of Kent, OH
- City of Marietta, OH
- City of New Albany, OH
- Stark County, OH
- Washington County, OH
- City of League City, TX
- City of Arlington, TN
- City of Lakeland, TN

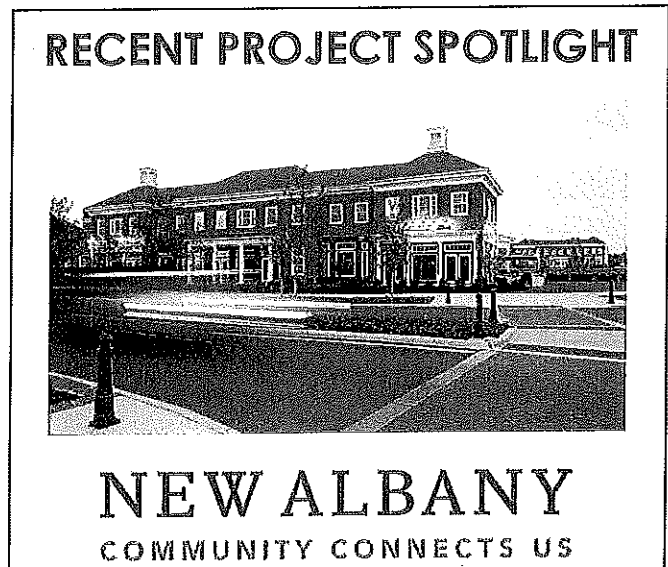

Over 4,500 centerline miles managed by PMG in 2020 alone

Section 2. Scope of Services

The Pavement Management Blueprint from PMG

Being within the pavement management sector for over 20 years, we have been able to make the necessary adjustments and pivots to meet the needs of our clients and engineering partners. The development of long term, optimized roadway management plans and programs hinges on quality data collection that is fully trusted, supported and continually improved upon. At PMG, we take pride and passion in delivering our solution in this manner, and the following scope of services within our blueprint provide a complete, data and map-driven pavement management solution.

The PMG Blueprint allows our partners and clients to fully leverage our standardized roadway condition assessment data for use in developing an optimized and long-term project plan. Not to mention, we also have a proprietary, completely cloud-based street condition map that includes the ability to not only search your roadway network and see roadway conditions, but the ability to stream High Definition video of our roadway network directly to the desktop and in a matter of seconds.

Commitment to Quality Data Collection

PMG is dedicated to capturing quality distress-based data to produce objective, repeatable and reliable Pavement Condition Index (PCI) values. There is an old saying within the industry, "garbage in, garbage out". With any long-term project plan, the reliability and accuracy of the data is key. James and his team have proven competency in this arena by completing coursework and obtaining specific credentials relating to pavement management and ASTM condition assessment through the University of Colorado State and the Metropolitan Transportation Commission. Each year, PMG performs tens of thousands of PCI calculations for municipalities in several states, with that number and regions helped growing each year.

A. Project Kickoff Meeting

PMG will host a one-hour online project kickoff meeting via Zoom to discuss the scope of work, establish the timeline, discuss deliverables, and define all resources required for the project. The project manager will present and request any additional information, data, files, maps, etc. at this meeting that would be deemed essential for completing the project on time.

B. Pavement Management System and Set Up

PMG leverages the PAVER pavement management system software to manage your street network inventory, conditions, and work history. Developed by the US Army Corps of Engineers using industry standards like the ASTM D6433 inspection process and Pavement Condition Index (PCI) for pavement condition reporting.

PMG procures your software and sets up all system tables and tools to create a tailored solution for your pavement project, maintenance, and costs. We fully license and manage your subscription and database while providing onsite installation for 2 licensed users. PAVER is included in PMG's turn-key solution, with no additional software related costs required.

COMPLETE PAVEMENT MANAGEMENT SERVICES PROPOSAL

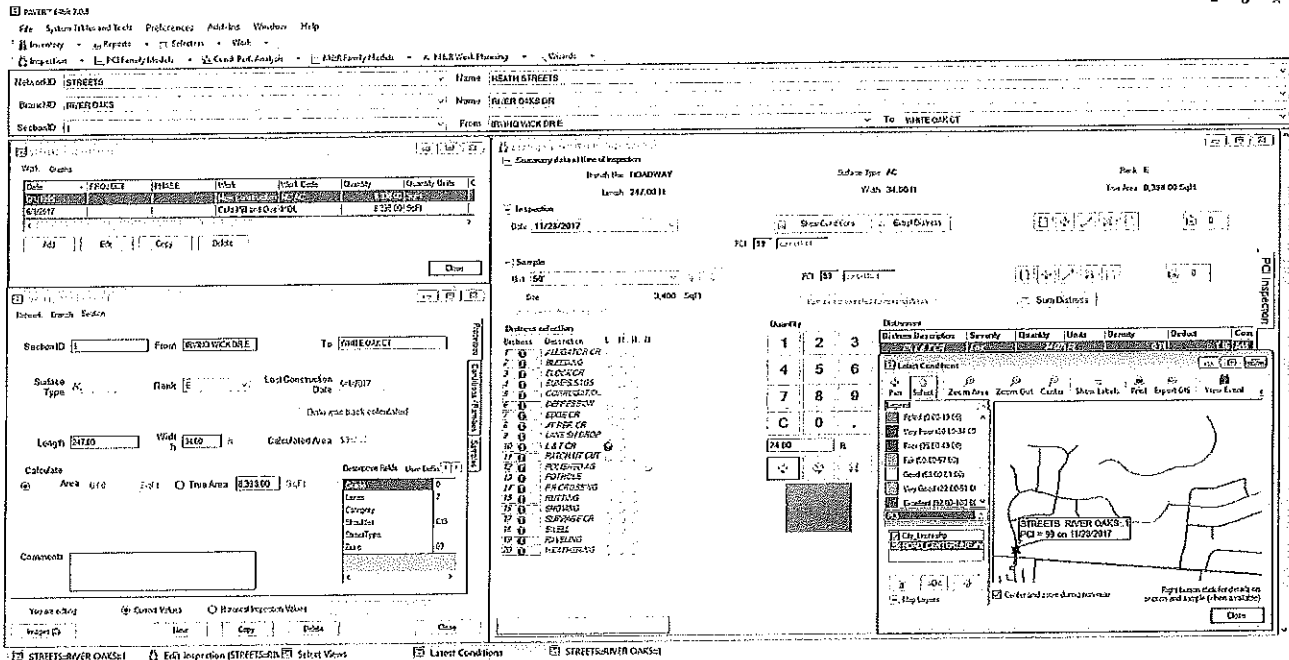

C. Network Inventory with High-Definition Video

We use aerial imagery and professional measuring tools from Google Earth Professional to produce a complete and accurate inventory of your maintained street network, all within the PAVER database (or Streetlogix software). For continuing services, PMG will provide accurate length, width and true area measurements for ALL sections within your Network while including any additional streets that need to be added or removed. Your street network inventory is organized by intersection with all standard attributes documented including: Section ID, From, To, Length, Width, Area, lanes, Surface, Last Construction date, Curb Type, Rank Class, etc.

They say a picture is worth a thousand words, and if this is believed to be true, then what value would you put on a complete high-definition video of every single roadway section within the entire network? AT PMG, we recognize the value of transparency, and seeing things as they are within the real world. We wanted to bring this unique experience to our valued customers, while leveraging the video for not only play back purposes, but to identify roadway distresses against the ASTM D6433 standard.

Our trained video capture team will leverage the complete and comprehensive inventory developed by the client and Project Manager to drive all roadways within your ownership to produce a single, 1080P full HD video for each roadway section. The process involves a driver wirelessly recording video in cabin through an externally mounted and connected GoPro camera, driving each roadway section continuously, below posted speed limits as to have little to no impact on the traveling public.

Each video captured will be renamed by Street Name and Section ID and provided on a 1TB external Hard Drive. By taking the time on our end to rename each video properly, our clients can have a fully searchable and indexed video log by both street name and section number that correlates to their street inventory beautifully.

To add additional value, ease of use and simplicity, our videos are also provided in an online, map-driven manner, called RoadInsights which is outlined in section G below.

COMPLETE PAVEMENT MANAGEMENT SERVICES PROPOSAL

In addition, this effort is also simultaneously working on the back end to provide our Ai algorithms the necessary distress information required for future Ai automation of this entire process. This once again demonstrates PMG's commitment to quality data within our industry by bringing the necessary ASTM D6433 based Ai to the marketplace that our current and future clients are looking for!

Labels 18,000 items

BUCKEYE_RAWY_04/18/MP4_2021.png	0	0
SECURITY_B9_05/MP4_207.png	1	1
DEHRAS_LH_06/MP4_192.png	1	0
MOONSHOWER_ST_04/MP4_155.png	1	0
HOOVER_RD_04/MP4_553.png	1	0
DEMOPRES_RD_09/MP4_1012.png	1	0
BROADHAM_DR_01/MP4_2120.png	1	0
WOODGROVE_DR_04/MP4_300.png	1	0
DEMOPRES_RD_03/MP4_08.png	1	0
MCDONELL_RD_04/MP4_057.png	1	0
SCOTO_MEADOWS_BLDV_01/MP4_3...	1	0

1-12 of 1876

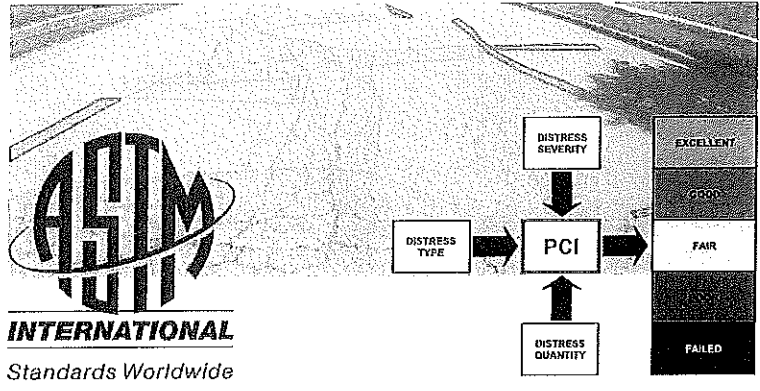

ASTM
INTERNATIONAL
Standards Worldwide

E. GIS Assignment and Condition Mapping

PMG will leverage the provided roadway centerline shapefile from the client and Project Manager and tie ALL your roadway network inventory to the condition assessment and PCI data collected and established by PMG. For this process, PMG will import your shapefile into the PAVER pavement management program and utilize the GIS assignment tool to make the connection between GIS segment and pavement section.

This process allows PMG to easily export all roadway inventory and condition items together into single, harmonious shapefile, and will provide this as a deliverable to the client for their internal GIS efforts. The following condition map highlights the benefits of GIS assignment in pavement management.

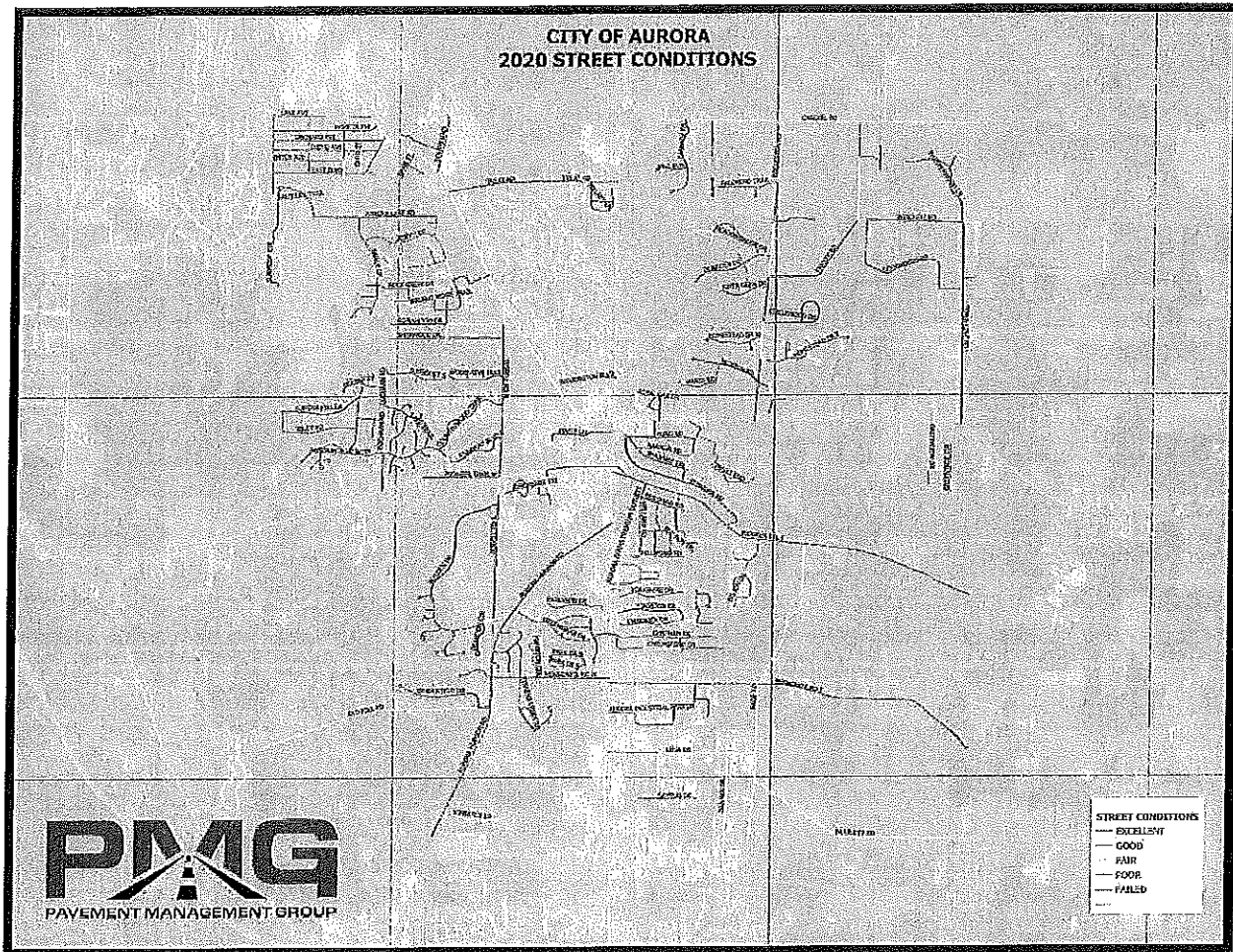

COMPLETE PAVEMENT MANAGEMENT SERVICES PROPOSAL

F. Final Project Deliverable

PMG will present a final project report and all project deliverables, via Zoom or on-site that includes:

- An executive summary and final project report.
- Current condition status of the street network.
- Published GIS map showing current street conditions by PMG assigned condition categories.
- Online accessible condition map with streaming street section videos
- All 1080P high-definition videos captured
- A variety of charts/graphs and GIS views.
- PAVER software installation, database connection and training (2 users) or Streetlogix data and system integration and training
- A 500GB external hard drive containing all project deliverables
- Continued consulting and support services

The collage displays several key deliverables from the project:

- 2018 PAVEMENT MANAGEMENT FINAL REPORT:** A cover page for Washington County, OH, dated Tuesday, July 17, 2018, featuring the PMG logo and the Washington County logo.
- TABLE OF CONTENTS:** A table listing the report's sections and their corresponding page numbers.
- EXECUTIVE SUMMARY:** A section providing a high-level overview of the project's findings and recommendations.
- ADDITIONAL PROJECT DELIVERABLES:** A list of supplementary materials provided, such as GIS maps and data files.
- CONCLUSION:** A summary of the project's outcomes and the value of the services provided.
- CHARTS AND GRAPHS:** Several data visualizations, including bar charts showing 'CONDITION BY ROAD TYPE' and 'CONDITION BY MILEAGE', and a GIS map of the street network.
- TABLES:** Data tables such as 'CONSTRUCTION BY ROAD TYPE' and 'CONSTRUCTION BY MILEAGE' showing metrics like miles, miles per day, and total miles.

G. RoadInsights - Data Management, Consulting & Support

PMG will provide our RoadInsights online dashboard with streaming video and up to 20 hours of data management, consulting, and support through 12/31/2021

This service includes (but is not limited to) inventory, work history, and network condition updates; budget and target driven scenarios, reporting; maintenance recommendations; GIS mapping; project planning; general consulting and support; presentation; pavement management system data import/export, etc.

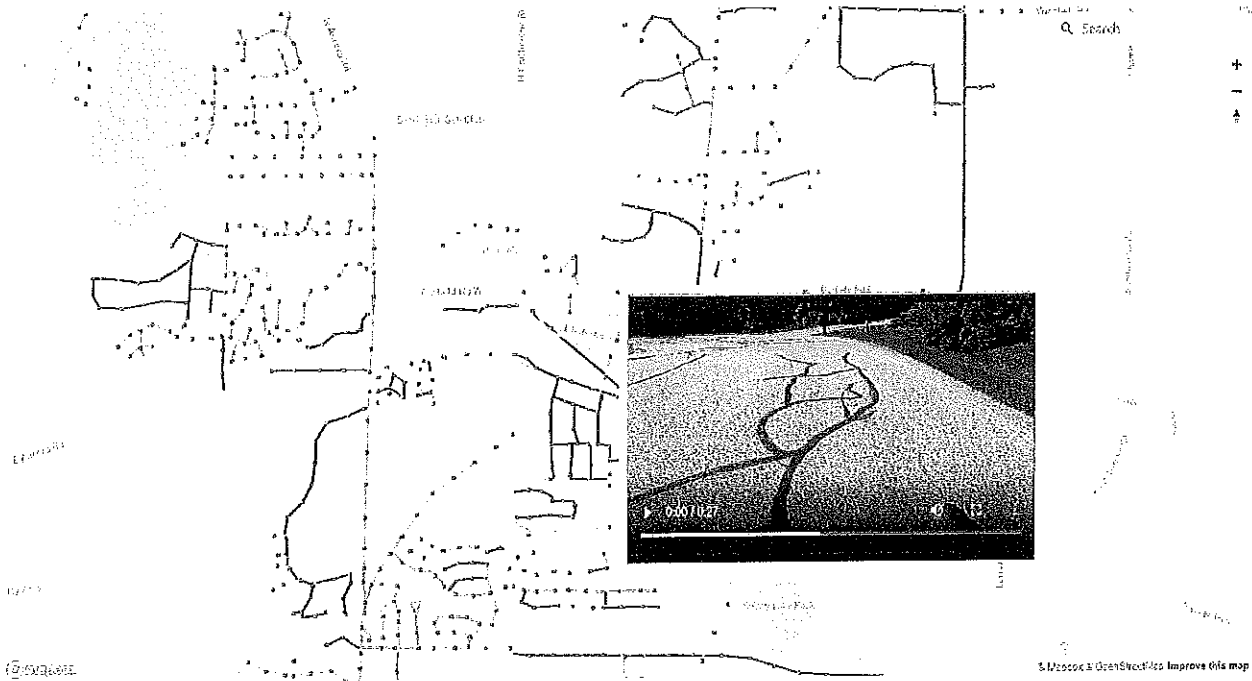

Section 3. Project Timeline

PMG recommends a project start date of Late Spring/Early Summer 2021 and can complete the scope of work items within a 90-workday period. Once a purchase order has been executed, PMG will host a project kickoff meeting to review the project and create the final project schedule.

Section 4. Project Costs and Terms

The cost to provide the complete continued pavement management services as outlined within the scope above is \$25,000.

TASK	PROJECT PERCENTAGE	TASK ITEM COST
A. Project Kickoff Meeting	5%	\$1,250.00
B. Pavement Management System and Setup	10%	\$2,500.00
C. Network Inventory with High-Definition Video	30%	\$7,500.00
D. ASTM D6433 Condition Assessment	40%	\$10,000.00
E. GIS Assignment and Condition Mapping	5%	\$1,250.00
F. Final Project Report and Deliverable Presentation	10%	\$2,500.00
G. RoadInsights with Managed Services (1 st Year Free!)	NA – ANNUAL FEE	\$1,995.00
TOTAL PROJECT COST:		\$25,000.00

PMG will invoice based upon project progress and in monthly intervals, typically the last week of the month. Project status reports and/or supporting documents will be provided as well. Payment terms are to be NET 30, and PMG greatly appreciates all efforts for prompt an on-time payments.

Section 6. Project Acceptance

Please complete the following section to approve and authorize this project, and email along with any other documents to: Sales@PavementManagement.com. Once received, our project manager will reach out to you to setup our project kickoff meeting.

Purchase Order Number:

Accepted By:

Authorized Signature

Date

Thank you for the opportunity to service your pavement management needs, we look forward to your decision!

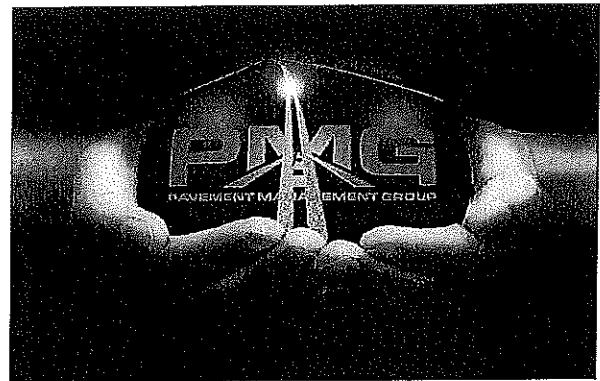

REQUEST FOR COUNCIL ACTION

No. RCA 21-122-6/14

FROM: Keith H. Dirham
DATE: Tuesday, May 25, 2021
SUBJECT: Elected Official Salaries

Committee: Finance

SUMMARY AND BACKGROUND:

Current salaries for elected officials were set by Ordinances 32-19 and 99-17 (attached, thank you Kathy). Under Ohio law and the City Charter, salaries for elected officials must be determined prior to the filing deadline for petitions for the position. Annual salaries as of 2021 for these positions are:

- \$92,006.55 for Finance Director
- \$86,594.40 for Mayor
- \$13,776 for Council President
- \$9,180 for Council Member

Note that the minimum salary necessary to earn a full month's credit in OPERS per OPERS website going forward is:

- \$696.84/mo or \$8,362.08/yr in 2022
- \$709.03/mo or \$8,508.36/yr in 2023
- \$721.44/mo or \$8,657.28/yr in 2024
- \$734.07/mo or \$8,808.84/yr in 2025
- \$746.91/mo or \$8,962.92/yr in 2026
- \$759.99/mo or \$9,119.88/yr in 2027
- \$773.29/mo or \$9,279.48/yr in 2028
- \$786.82/mo or \$9,441.84/yr in 2029

Thus, the current Council Member salary is sufficient to earn a full year's credit in OPERS through 2027 but after that it will not be. Furthermore, the minimum monthly earnable salary required to earn service credit for health care coverage is \$1,000 (\$12,000/yr) and no partial credit is available for health care so at present the Council President is earning credit toward health care coverage in retirement but the other Council Members are not.

In the past I have requested and Council has agreed to make all of these evenly divisible by the number of pay-periods per year for these officials. I would request that again because it simplifies things for my payroll clerk.

*Keith - Have to set salaries prior to filing deadline
Council member earnings credit towards healthcare.*

Estimated Cost:

Suggested Funding:

- sufficient funds in Account No.
- transfer needed from Account No. to Account No.
- NEW APPROPRIATION needed in Account No.

*- Make Council salaries divisible by 12
- Eric - Should be \$1,000/mo.
Bill - Term limits should be enforced
Paul - Give Mayor + Fin Director Col R*

Emergency Clause Requested:

Reason:

COUNCIL USE ONLY:

Committee Action/Recommendation:

*6/14/21 Council
Stay same
Charter Review
look*

Council Action Taken:

Ord./Res.
Date:

Salary Review

Rec'd

6-22-21

RCA 21-122-6/14

Background

An Ad Hoc committee was asked to consider the salaries for the elected positions of the Mayor, Finance Director and City Council and offer their suggestion for raises over the next four years. The committee met on June 18th and consisted of the following members:

- Stacy Bonitz
- Raymond Rogers
- Debra Hallock
- Annette Wissel

Mayor

The Mayor's current salary is \$86,594.40 and the position has received a 2% raise over the last four years representing an inflationary adjustment approved by Council.

Finance Director

The Finance Director's current salary is \$92,006.55 and the position has received a 2% raise over the last four years representing an inflationary adjustment approved by Council.

City Council

The City Council's current salary, excluding the City Council President, is \$9,180 and the members received a 32% increase on average in 2018 and a 5% raise on average thereafter to make-up for the previous nine years of no adjustment, align all members to be the same, and allow members to earn full credit from Ohio's Public Employees Retirement System (OPERS) for their service.

City Council President

The City Council President's current salary is \$13,776 representing a differential of 50% from other Council members. The President received a 46% raise in 2020 and a 4.5% raise in 2021 to maintain the 50% differential and make-up for the previous nine years of no adjustment.

Analysis

Mayor and Finance Director

Comparable salaries from Strongsville, Brunswick, Wadsworth and Wooster were reviewed for these positions. For the Mayor, only a comparison with Brunswick was considered since the other city's administrative structure did not allow a fair comparison. The committee also discussed the economic outlook and inflationary pressures on the cost-of-living. Based on the fact the Mayor and Finance Director salaries are below the average of these surrounding cities and the anticipated increase in the cost-of-living, a slightly higher raise than the previous years seemed appropriate.

City Council

Comparable salaries from Strongsville, Brunswick, Wadsworth and Wooster as well as the minimum salary necessary to earn a full month's credit in OPERS for 2024 and 2025 were reviewed. Adding to the discussion was the minimum monthly salary required to earn service credit for health care coverage of \$1,000 per month. Medina's current salary is sufficient to earn a full year's credit in OPERS for the years in consideration but is still below the average and minimum salary to earn service credit for health care coverage. The committee felt a 31% increase in 2024 to reach the \$12,000 threshold was not necessary at this time but instead an increase above a cost-of-living adjustment will work toward this amount and close the gap from surrounding cities in hopes to attract the best people to serve the city was appropriate.

City Council President

Comparable salaries from Strongsville, Brunswick, Wadsworth and Wooster were reviewed for City Council President as well as the 50% differential from the other council members. Because the current salary is above the average of surrounding communities coupled with the raise recommended for the other members, the committee felt the differential could be reduced instead.

Recommendation

Mayor

A 2.5% raise (to be adjusted for the years with 27 pays)

YEAR	Annual Salary (26 Pay Year)
2022	\$ 88,759.32
2023	\$ 90,978.16
2024	\$ 93,252.64
2025	\$ 95,584.06

Finance Director

A 2.5% raise (to be adjusted for the years with 27 pays)

YEAR	Annual Salary (26 Pay Year)
2022	\$ 94,306.68
2023	\$ 96,664.36
2024	\$ 99,081.06
2025	\$ 101,558.08

City Council

A 10% raise

YEAR	Annual Salary (26 Pay Year)
2024	\$ 10,098.00
2025	\$ 11,107.80

City Council President

A 5% raise

YEAR	Annual Salary (26 Pay Year)
2024	\$ 14,464.80
2025	\$ 15,188.04

Elected Official Salary Comparison		As % of Medina 2021		
Mayor/City Manager	2021	2022	2021	2022
Strongsville	150,000.00		173.22%	0.00%
Brunswick^	125,561.90	128,073.14	145.00%	147.90%
Medina	86,594.40		100.00%	0.00%
Wadsworth	48,172.00	49,376.00	55.63%	57.02%
Wooster	75,645.00		87.36%	0.00%
Average	97,194.66			
Median	86,594.40			
Finance Director	2021	2022	2021	2022
Strongsville	137,987.20		149.98%	0.00%
Brunswick	107,557.84		116.90%	0.00%
Medina	92,006.55		100.00%	0.00%
Wadsworth*	89,530.00	91,321.00	97.31%	99.25%
Wooster	140,109.00		152.28%	0.00%
Average	113,438.12			
Median	107,557.84			
Council President	2021	2022	2021	2022
Strongsville	20,091.18		145.84%	0.00%
Brunswick	13,665.44		99.20%	0.00%
Medina	13,776.00		100.00%	0.00%
Wadsworth	8,668.00	8,668.00	62.92%	62.92%
Wooster	9,500.00		68.96%	0.00%
Average	13,140.12			
Median	13,665.44			
Council Member	2021	2022	2021	2022
Strongsville	18,841.79		205.25%	0.00%
Brunswick	14,749.83		160.67%	0.00%
Medina	9,180.00		100.00%	0.00%
Wadsworth	8,185.00	8,185.00	89.16%	89.16%
Wooster	8,500.00		92.59%	0.00%
Average	11,891.32			
Median	9,180.00			

*The salary listed is for Wadsworth's City Auditor. They also have a City Treasurer who is paid \$32,684 for 2021. The sum of the two for 2021 is 122,214.00

^The salary listed is for the Brunswick City Manager. They also have a Mayor who is paid \$16,227.40 for 2021. The sum of the two for 2021 is 141,789.30

ORDINANCE NO. 32-19

AN ORDINANCE AMENDING ORDINANCE NO. 103-17, PASSED JULY 10, 2017, RELATIVE TO SECTION 31.01 OF THE SALARY AND BENEFITS CODE, THE SCHEDULE OF PAY FOR THE POSITIONS OF MEMBERS OF COUNCIL.

WHEREAS: Ordinance No. 103-17, passed July 10, 2017, authorized the amending Section 31.01 of the Salary and Benefits Code, the Schedule of Pay for the positions of Members of Council; and

WHEREAS: That Section 31.01 of the Salaries and Benefits Code pertaining to Schedule of Pay for Members of Council presently reads as follows:

President of Council (Term 1/1/16-12/31-19)	\$ 9,000.00 (Annual – 2018)	Payable Monthly
	\$ 9,000.00 (Annual – 2019)	Payable Monthly
	\$13,140.00 (Annual – 2020)	Payable Monthly
	\$13,776.00 (Annual – 2021)	Payable Monthly

Council Members (1/1/18-12/31/21)		
Ward 1 Council	\$ 7,920.00 (Annual – 2018)	Payable Monthly
Ward 3 Council	\$ 8,340.00 (Annual – 2019)	Payable Monthly
At-Large Council (Rose)	\$ 8,760.00 (Annual – 2020)	Payable Monthly
	\$ 9,180.00 (Annual – 2021)	Payable Monthly

Council Members (1/1/16-12/31/19)		
Ward 2 Council	\$ 6,000.00 (Annual – 2018)	Payable Monthly
Ward 4 Council	\$ 6,000.00 (Annual – 2019)	Payable Monthly
At-Large Council (Lamb)	\$ 8,760.00 (Annual – 2020)	Payable Monthly
	\$ 9,180.00 (Annual – 2021)	Payable Monthly

(Ord. 103-17)

NOW, THEREFORE, BE IT ORDAINED BY THE COUNCIL OF THE CITY OF MEDINA, OHIO:

SEC. 1: That Section 31.01 of the Salary and Benefits Code pertaining to Schedule of Pay for Members of Council shall be amended to read as follows:

President of Council (Term 1/1/16-12/31/23)	\$ 9,000.00 (Annual – 2019)	Payable Monthly
	\$13,140.00 (Annual – 2020)	Payable Monthly
	\$13,776.00 (Annual – 2021)	Payable Monthly
	\$13,776.00 (2022 & 2023+)*	Payable Monthly

Council Members (1/1/18-12/31/23)

Ward 1 Council	\$ 8,340.00 (Annual – 2019)	Payable Monthly
Ward 3 Council	\$ 8,760.00 (Annual – 2020)	Payable Monthly
At-Large Council (Rose)	\$ 9,180.00 (Annual – 2021)	Payable Monthly
	\$9,180.00 (2022 & 2023+)*	Payable Monthly

Council Members (1/1/16-12/31/23)

Ward 2 Council	\$ 6,000.00 (Annual – 2019)	Payable Monthly
Ward 4 Council	\$ 8,760.00 (Annual – 2020)	Payable Monthly
At-Large Council (Lamb)	\$ 9,180.00 (Annual – 2021)	Payable Monthly
	\$ 9,180.00 (2022 & 2023+)*	Payable Monthly

***The salaries after 2023 shall stay the same until Council should take further action to increase at that time.**

(Ord. 103-17, 32-19)

SEC. 3: That it is found and determined that all formal actions of this Council concerning and relating to the passage of this Ordinance were adopted in an open meeting of this Council, and that all deliberations of this Council and any of its committees that resulted in such formal action, were in meetings open to the public, in compliance with the law.

SEC. 4: That this Ordinance shall be in full force and effect at the earliest period allowed by law.

PASSED: February 25, 2019

SIGNED: John M. Coyne, III
President of Council

ATTEST: Kathy Patton
Clerk of Council

APPROVED: February 26, 2019

SIGNED: Dennis Hanwell
Mayor

ORDINANCE NO. 99-17

AN ORDINANCE AMENDING SECTION 31.01 OF THE SALARIES AND BENEFITS CODE OF THE CITY OF MEDINA, OHIO RELATIVE TO THE SCHEDULE OF PAY FOR THE POSITIONS OF MAYOR, DIRECTOR FINANCE AND MEMBERS OF COUNCIL.

WHEREAS: Section 31.01 of the Salaries and Benefits Code of the City of Medina, Ohio relative to the Schedule of Pay for Elected Officials presently reads as follows:

All elected officials of the City of Medina, Ohio, shall be paid a salary in accordance with the following schedule of pay basis:

Director of Finance*	\$82,997.98 (Annual - 2014)	Payable Bi-weekly
	\$83,659.94 (Annual - 2015)	Payable Bi-weekly
	\$84,327.36 (Annual - 2016)	Payable Bi-weekly
	\$84,999.98 (Annual - 2017)	Payable Bi-weekly
(Ord. 42-00, 171-05, 108-09, 110-13)		
Mayor*	\$75,319.14 (Annual – 2014)	Payable Bi-weekly
	\$76,848.20 (Annual - 2015)	Payable Bi-weekly
	\$78,408.20 (Annual - 2016)	Payable Bi-weekly
	\$79,999.92 (Annual - 2017)	Payable Bi-weekly
(Ord. 43-00, 170-05, 171-07, 107-09, 109-13)		
President of Council	\$9,000.00 (Annual)	Payable Monthly
Council Member	\$6,000.00 (Annual)	Payable Monthly
(Ord. 41-00, 86-05, 169-05)		
Municipal Court Judge *	ORC 1901.11	Payable Bi-weekly
Clerk of Court*	ORC 1901.31	Payable Bi-weekly
(Ord.. 26-07)		

* Officials eligible to receive hospitalization benefits.

NOW, THEREFORE, BE IT ORDAINED BY THE COUNCIL OF THE CITY OF MEDINA, OHIO:

SEC. 1: That Section 31.01 of the Salaries and Benefits Code of the City of Medina, Ohio shall be amended in part as follows relative to the Schedule of Pay for Elected Officials:

SECTION 31.01 SCHEDULE OF PAY FOR ELECTED OFFICIALS

All elected officials of the City of Medina, Ohio, shall be paid a salary in accordance with the following schedule of pay basis:

Director of Finance*	\$86,699.86 (Annual - 2018)	Payable Bi-weekly
	\$88,433.80 (Annual - 2019)	Payable Bi-weekly
	\$90,202.58 (Annual - 2020)	Payable Bi-weekly
	\$92,006.55 (Annual - 2021)	Payable Bi-weekly
(Ord. 42-00, 171-05, 99-17)		
Mayor*	\$81,599.96 (Annual - 2018)	Payable Bi-weekly
	\$83,231.98 (Annual - 2019)	Payable Bi-weekly
	\$84,896.50 (Annual - 2020)	Payable Bi-weekly
	\$86,594.40 (Annual - 2021)	Payable Bi-weekly
(Ord. 43-00, 170-05, 171-07, 109-13, 99-17)		
President of Council	\$11,880.00 (Annual - 2018)	Payable Monthly
	\$12,516.00 (Annual - 2019)	Payable Monthly
	\$13,140.00 (Annual - 2020)	Payable Monthly
	\$13,776.00 (Annual - 2021)	Payable Monthly
Council Member	\$7,920.00 (Annual - 2018)	Payable Monthly
	\$8,340.00 (Annual - 2019)	Payable Monthly
	\$8,760.00 (Annual - 2020)	Payable Monthly
	\$9,180.00 (Annual - 2021)	Payable Monthly
(Ord. 41-00, 86-05, 169-05, 99-17)		
Municipal Court Judge *	ORC 1901.11	Payable Bi-weekly
Clerk of Court*	ORC 1901.31	Payable Bi-weekly
(Ord.. 26-07)		

SEC. 2: That in accordance with Article III, Section 12 of the Charter of the City of Medina, Ohio, the above referenced increases shall take effect for those officials taking office January 1, 2018.

SEC. 3: That it is found and determined that all formal actions of this Council concerning and relating to the passage of this Ordinance were adopted in an open meeting of this Council, and that all deliberations of this Council and any of its committees that

resulted in such formal action, were in meetings open to the public, in compliance with the law.

SEC. 4: That this Ordinance shall be in full force and effect at the earliest period allowed by law.

PASSED: June 26, 2017

SIGNED: John M. Coyne, III
President of Council

ATTEST: Kathy Patton
Clerk of Council

APPROVED: June 27, 2017

SIGNED: Dennis Hanwell
Mayor

Year	Annualized 43-A	Annualized 43-F	Cumulative %	Council Low	Council High	Cumulative %	Council President	Cumulative %	Meyer	Cumulative %	Finance Director	Cumulative %
2002	57,552.80	73,403.20		3,200.00	3,200.00	0.00%	3,600.00	0.00%	50,000.00	0.00%	60,000.00	0.00%
2003	58,676.80	74,859.20	1.88%	3,200.00	3,200.00	0.00%	3,600.00	0.00%	50,000.00	0.00%	60,000.00	0.00%
2004	60,424.00	77,105.60	3.00%	3,200.00	3,200.00	0.00%	3,600.00	0.00%	50,000.00	10.00%	65,000.00	8.33%
2005	62,857.60	80,204.80	4.02%	3,200.00	3,200.00	0.00%	3,600.00	0.00%	55,000.00	0.00%	65,000.00	0.00%
2006	65,083.20	83,075.20	3.58%	3,200.00	3,200.00	0.00%	3,600.00	0.00%	58,550.00	3.00%	66,950.00	3.00%
2007	67,371.20	85,987.20	3.51%	5,400.00	5,400.00	68.75%	3,600.00	87.50%	58,550.00	3.00%	68,959.00	3.00%
2008	69,742.40	89,008.20	3.51%	6,000.00	6,000.00	11.11%	9,000.00	87.50%	60,100.00	3.00%	71,028.00	3.00%
2009	71,988.80	91,894.40	3.35%	6,000.00	6,000.00	0.00%	9,000.00	87.50%	61,993.00	3.00%	73,159.00	3.00%
2010	74,152.00	94,640.00	2.99%	6,000.00	6,000.00	0.00%	9,000.00	87.50%	64,686.52	4.50%	75,353.72	3.00%
2011	75,254.40	96,033.60	1.47%	6,000.00	6,000.00	0.00%	9,000.00	87.50%	67,599.94	4.50%	77,614.42	3.00%
2012	76,772.80	98,009.60	2.06%	6,000.00	6,000.00	0.00%	9,000.00	87.50%	70,641.74	4.50%	79,942.72	3.00%
2013	78,666.40	100,448.20	2.48%	6,000.00	6,000.00	0.00%	9,000.00	87.50%	73,820.50	4.50%	82,341.22	3.00%
2014	80,267.20	102,460.80	2.01%	6,000.00	6,000.00	0.00%	9,000.00	87.50%	75,118.14	2.03%	82,997.98	0.80%
2015	81,827.20	104,457.60	1.95%	6,000.00	6,000.00	0.00%	9,000.00	87.50%	76,848.20	2.03%	83,659.94	0.80%
2016	83,470.40	106,537.60	1.98%	6,000.00	6,000.00	0.00%	9,000.00	87.50%	78,408.20	2.03%	84,327.36	0.80%
2017	85,592.00	109,241.60	2.54%	6,000.00	6,000.00	32.00%	9,000.00	147.50%	79,999.92	2.03%	84,999.98	0.80%
2018	87,526.40	111,716.80	2.27%	6,000.00	6,000.00	0.00%	9,000.00	160.65%	81,599.96	2.00%	86,699.86	2.00%
2019	89,273.60	113,942.40	1.99%	6,000.00	6,000.00	5.30%	9,000.00	173.75%	83,231.98	2.00%	88,433.80	2.00%
2020	91,520.00	116,812.80	2.52%	8,760.00	8,760.00	5.04%	13,140.00	186.88%	84,895.50	2.00%	90,202.58	2.00%
2021	97,437.60	124,372.80	6.47%	9,180.00	9,180.00	4.78%	13,776.00		86,594.40	2.00%	92,006.55	2.00%

REQUEST FOR COUNCIL ACTION

No. RCA 21-123-6/14
Committee: Finance

FROM: Keith H. Dirham
DATE: Tuesday, May 25, 2021
SUBJECT: 2022 Tax Budget

SUMMARY AND BACKGROUND:

Placeholder, details to follow.

Estimated Cost:

Suggested Funding:

- sufficient funds in Account No.
- transfer needed from Account No. to Account No.
- NEW APPROPRIATION needed in Account No.

Emergency Clause Requested:

Reason:

COUNCIL USE ONLY:

Committee Action/Recommendation:

Council Action Taken: HOLD

Ord./Res.
Date:



132 North Elmwood Ave.
P.O. Box 703
Medina, Ohio 44258-0703
Phone: 330-725-8861
Fax: 330-722-9045
www.medinaoh.org

To: Council, Mayor

From: Keith H. Dirham, Director of Finance

Re: 2022 Tax Budget

Date: Tuesday, June 22, 2021

Attached is your copy of the Tax Budget. The comparative millages are offered for your review.

	2016	2017	2018	2019	2020	2021	2022
Inside Millage							
General Fund	2.30	2.30	2.10	2.10	2.10	2.00	2.10
Police Pension	0.90	0.90	1.10	1.10	1.10	1.20	1.10
Outside Millage							
Ambulance	2.20	2.20	2.20	2.20	2.20	2.20	2.20
Inside total	3.20	3.20	3.20	3.20	3.20	3.20	3.20

**City of Medina
Schedule A**

Fund (requesting general property Tax)	Requested of Budget Commission	Approved by Budget Commission Inside	Amount Derived from Levies Outside	County Auditor's Estimate of Tax Rate to be Levied	
				Inside	Outside
Government Funds					
General Fund	\$ 1,850,000.00				
Police and Fire Disability Pension	\$ 700,000.00				
Emergency Medical Service	\$ 2,000,000.00				
Fire Bond Retirement	\$ -				
Total All Funds	\$ 4,550,000.00				

**City of Medina
General Fund**

Exhibit I

Description (1)	Actual		Current Est.	Budget Est
	2019 (2)	2020 (3)	2021 (4)	2022 (5)
Revenues				
Local taxes				
General Property Tax - Real Estate	1,136,602.43	1,273,199.72	1,187,963.00	1,214,778.00
Tangible Personal Property Tax				
Municipal Income Tax	3,765,191.84	3,834,617.93	3,522,000.00	3,571,000.00
Other Local Taxes				
Total Local Taxes	4,901,794.27	5,107,817.65	4,709,963.00	4,785,778.00
Intergovernmental Revenues				
State Shared Taxes and Permits				
Local Government - County and State	456,906.82	509,231.43	405,000.00	405,000.00
Estate Tax	-	-	-	-
Cigarette Tax	2,593.25	2,440.63	2,700.00	2,700.00
Lodging Tax	1,107.68	1,014.14	850.00	850.00
Liquor and Beer Permits	30,638.65	13,114.85	25,000.00	25,000.00
Gasoline Tax				
Library and Local Government Support Fund				
Property Tax Allocation	126,598.83	141,725.55	132,237.00	135,222.00
Other State Shared Taxes	28,990.29	223,918.98	6,150.00	6,150.00
Total State Shared Taxes and Permits	646,835.52	891,445.58	571,937.00	574,922.00
Federal Grants or Aid				
State Grants or Aid				
Other Grants or Aid				
Total Intergovernmental Revenues	646,835.52	891,445.58	571,937.00	574,922.00
Special Assessments				
Charges for Services	331,478.86	315,195.86	309,500.00	309,500.00
Fines Licenses, and Permits	1,267,951.26	1,021,373.46	1,144,800.00	1,144,800.00
Miscellaneous	579,552.75	722,760.56	408,750.00	408,750.00
Other Financing Sources:				
Proceeds from Sale of Debt				
Transfers				
Advances	1,695,606.00	8,060,828.00		
Other Sources	1,395.99		5,000.00	5,000.00
Total Revenue	9,424,614.65	16,119,421.11	7,149,950.00	7,228,750.00

**City of Medina
General Fund**

Exhibit I

Description (1)	2019 (2)	2020 (3)	Current Est. 2021 (4)	Budget Est 2022 (5)
Expenditures				
Security of Persons and Property				
Personal Services				
Travel Transportation				
Contractual Services	140,831.92	194,927.01	198,868.26	203,729.49
Supplies and Materials	18,505.63	25,613.84	26,131.74	26,770.51
Capital Outlay				
Total Security of Persons and Property	159,337.55	220,540.85	225,000.00	230,500.00
Public Health Services				
Personal Services	104,884.42	89,465.41	117,147.24	118,988.77
Travel Transportation				
Contractual Services	15,840.88	13,512.12	17,692.96	17,971.08
Supplies and Materials	39,624.43	33,799.27	44,257.23	44,952.94
Capital Outlay	52,606.00	44,872.42	58,756.57	59,680.21
Total Public Health Services	212,955.73	181,649.22	237,854.00	241,593.00
Leisure Time Activities				
Personal Services				
Travel Transportation				
Contractual Services				
Supplies and Materials				
Capital Outlay				
Total Leisure Time Activities	-	-	-	-
Community Environment				
Personal Services	585,642.08	566,590.31	713,775.22	744,099.76
Travel Transportation				
Contractual Services	144,990.55	140,273.81	176,713.15	184,220.77
Supplies and Materials	23,307.22	22,549.00	28,406.63	29,613.47
Capital Outlay				
Total Community Environment	753,939.85	729,413.12	918,895.00	957,934.00
Basic Utility Services				
Personal Services			1,185.00	1,185.00
Travel Transportation				
Contractual Services				
Supplies and Materials				
Capital Outlay				
Total Basic Utility Services	-	-	1,185.00	1,185.00

**City of Medina
General Fund**

Exhibit I

Description (1)	4	Current Est. 2019 (2)	Current Est. 2020 (3)	Current Est. 2021 (4)	Budget Est 2022 (5)
Transportation					
Personal Services					
Travel Transportation					
Contractual Services					
Supplies and Materials					
Capital Outlay					
Total Transportation		-	-	-	-
General Government					
Personal Services		4,349,201.63	4,276,729.14	4,446,249.03	4,894,022.85
Travel Transportation					
Contractual Services		1,247,310.91	1,226,526.48	1,275,143.21	1,403,560.62
Supplies and Materials		615,497.02	605,240.75	629,231.12	692,599.87
Capital Outlay		7,265.52	7,144.45	7,427.64	8,175.66
Total General Government		6,219,275.08	6,115,640.82	6,358,051.00	6,998,359.00
Debt Service					
Redemption of Principal					
Interest					
Other Debt Service					
Total Debt Service		-	-	-	-
Other Uses of Funds					
Transfers		60,000.00	61,000.00	117,500.00	120,000.00
Advances		6,057,435.00	4,509,419.00		
Contingencies					
Other Uses of Funds					
Total Other Uses of Funds		6,117,435.00	4,570,419.00	117,500.00	120,000.00
Total Expenditures		13,462,943.21	11,817,663.01	7,858,485.00	8,549,571.00
Revenues over/(under) Expenditures		(4,038,328.56)	4,301,758.10	(708,535.00)	(1,320,821.00)
Beginning Unencumbered Balance *		4,425,783.21	387,454.65	4,689,212.75	3,980,677.75
Ending Cash Fund Balance		387,454.65	4,689,212.75	3,980,677.75	2,659,856.75
Estimated Encumbrances outstanding at Year End		151,379.10	555,585.71	300,000.00	350,000.00
Estimated Ending Unencumbered Fund Balance		236,075.55	4,133,627.04	3,680,677.75	2,309,856.75

* Cash Balance used because estimated expenditures includes PY encumbrances

**City of Medina
Police and Fire Pension Fund
Special Revenue**

Description (1)	Actual		Current Est.	Budget Est
	2019 (2)	2020 (3)	2021 (4)	2022 (5)
Revenues				
Local taxes				
General Property Tax - Real Estate	594,900.21	666,690.16	722,052.00	728,075.00
Tangible Personal Property Tax				
Other Local Taxes	583.90	775.19	840.00	847.00
Total Local Taxes	595,484.11	667,465.35	722,892.00	728,922.00
Intergovernmental Revenues				
State Shared Taxes and Permits				
Property Tax Allocation	66,322.45	74,242.71	80,408.00	81,078.00
Total Intergovernmental Revenues	66,322.45	74,242.71	80,408.00	81,078.00
Other Financing Sources:				
Advances				
Other Sources				
Total Revenue	661,806.56	741,708.06	803,300.00	810,000.00
Expenditures				
Security of Persons and Property				
Personal Services	624,591.27	618,241.39	691,301.00	783,342.00
Contractual Services	11,926.38	14,054.66	19,500.00	19,500.00
Total Security of Persons and Property	636,517.65	632,296.05	710,801.00	802,842.00
Other Uses of Funds				
Advances				
Contingencies				
Other Uses of Funds				
Total Other Uses of Funds	-	-	-	-
Total Expenditures	636,517.65	632,296.05	710,801.00	802,842.00
Revenues over/(under) Expenditures	25,288.91	109,412.01	92,499.00	7,158.00
Beginning Unencumbered Balance	1,301,179.32	1,326,468.23	1,435,880.24	1,528,379.24
Ending Cash Fund Balance	1,326,468.23	1,435,880.24	1,528,379.24	1,535,537.24
Estimated Encumbrances outstanding at Year End	-	-	-	-
Estimated Ending Unencumbered Fund Balance	1,326,468.23	1,435,880.24	1,528,379.24	1,535,537.24

City of Medina
EMS Fund
Special Revenue

Description (1)	Actual		Current Est.	Budget Est
	2019 (2)	2020 (3)	2021 (4)	2022 (5)
Revenues				
Local taxes				
General Property Tax - Real Estate	983,629.52	986,038.50	1,584,260.00	1,622,293.00
Tangible Personal Property Tax				
Other Local Taxes	976.00	1,129.00	1,814.00	1,858.00
Total Local Taxes	984,605.52	987,167.50	1,586,074.00	1,624,151.00
Intergovernmental Revenues				
Property Tax Allocation	109,772.07	106,881.88	171,726.00	175,849.00
Other Financing Sources:				
Other Sources				
Total Revenue	1,094,377.59	1,094,049.38	1,757,800.00	1,800,000.00
Expenditures				
Security of Persons and Property				
Personal Services				
Travel Transportation				
Contractual Services	1,366,915.94	1,333,673.70	1,475,850.00	1,525,850.00
Supplies and Materials				
Capital Outlay	-	-		
Total Security of Persons and Property	1,366,915.94	1,333,673.70	1,475,850.00	1,525,850.00
Other Uses of Funds				
Transfers				
Total Expenditures	1,366,915.94	1,333,673.70	1,475,850.00	1,525,850.00
Revenues over/(under) Expenditures	(272,538.35)	(239,624.32)	281,950.00	274,150.00
Beginning Unencumbered Balance	947,758.31	675,219.96	435,595.64	717,545.64
Ending Cash Fund Balance	675,219.96	435,595.64	717,545.64	991,695.64
Estimated Encumbrances outstanding at Year End	129,868.71	150,079.26	225,000.00	225,000.00
Estimated Ending Unencumbered Fund Balance	545,351.25	285,516.38	492,545.64	766,695.64

City of Medina
Other Funds (Not Reported on Exhibit I or II)

Exhibit III

Fund	Fund	Est Unenc Fund Bal 1/1/2022	Budget Year Estimated Receipt	Total Avail For Expenditures	Budget Year Expenditures and Encumbrances			Estimated Unenc Bal 12/31/2022
					Personal	Services	Other	
Governmental Funds								
Special Revenue Fund Type								
102	Street M & R	999,375.85	1,738,400.00	2,737,775.85	600,000.00	1,070,804.00	1,670,804.00	1,066,971.85
103	State Highway	344,049.12	134,060.00	478,109.12	35,000.00	62,764.00	97,764.00	380,345.12
104	Parks and Recreation	1,904,552.90	1,153,400.00	3,057,952.90	475,000.00	729,743.00	1,204,743.00	1,853,209.90
105	Local License Fee	2,076,273.60	237,500.00	2,313,773.60	253,500.00	253,500.00	253,500.00	2,060,273.60
106	Police Special	8,346,343.16	6,063,000.00	14,409,343.16	4,200,000.00	2,404,468.00	6,604,468.00	7,804,875.16
107	Fire Special	1,180,094.69	1,290,850.00	2,470,944.69	700,000.00	653,345.00	1,353,345.00	1,117,599.69
108	Street M & R Special	1,527,148.61	2,893,500.00	4,420,648.61	-	2,880,000.00	2,880,000.00	1,540,648.61
109	Grants	911,757.24	-	911,757.24	-	-	-	911,757.24
110	ODNR State Grants	195,053.00	-	195,053.00	-	-	-	195,053.00
111	Income Tax	-	-	-	-	-	-	-
112	COPS 1	-	-	-	-	-	-	-
114	COPS 2	-	-	-	-	-	-	-
115	County Local License Fee	180,132.90	60,500.00	240,632.90	-	64,770.00	64,770.00	175,862.90
116	State DARE Grant	5,100.82	-	5,100.82	-	-	-	5,100.82
117	COPS 3 - COPS More	-	-	-	-	-	-	-
118	COPS Universal	-	-	-	-	-	-	-
119	Multi Diversion Program	-	-	-	-	-	-	-
120	COPS More '96	-	-	-	-	-	-	-
121	COPS More '98	-	-	-	-	-	-	-
123	FEMA	-	-	-	-	-	-	-
124	COPS in Schools	-	-	-	-	-	-	-
125	CDBG	198,093.80	170,000.00	368,093.80	-	-	-	368,093.80
127	CHIP Grant	650,000.00	650,000.00	1,300,000.00	-	-	-	1,300,000.00
128	Court Security Grant	-	-	-	-	-	-	-
129	Ohio Housing Trust	39,535.20	-	39,535.20	-	-	-	39,535.20
130	Open Space 1	33,151.41	-	33,151.41	-	-	-	33,151.41
131	Open Space 2	1,595.29	-	1,595.29	-	-	-	1,595.29
132	Open Space 3	-	-	-	-	-	-	-
133	Open Space 4	-	-	-	-	-	-	-
134	Non-Point Source Grant	-	-	-	-	-	-	-
136	Micro-Enterprise Revolving Loan Fund	-	-	-	-	-	-	-
137	CHIP Revolving Loan Fund	84,292.60	-	84,292.60	-	-	-	84,292.60
138	CDBG-CHIP CFDA 14.2	197,255.22	-	197,255.22	-	-	-	197,255.22
139	HOME-CHIP CFDA 14.2	300,284.15	-	300,284.15	-	-	-	300,284.15
140	Parking	2,946.92	85,000.00	87,946.92	50,000.00	36,486.00	86,486.00	1,460.92
141	Medina Square Lighting	75,000.00	-	75,000.00	-	-	-	75,000.00
143	Economic Development	177,466.26	55,000.00	232,466.26	-	27,000.00	27,000.00	205,466.26

City of Medina
Other Funds (Not Reported on Exhibit I or II)

Exhibit III

Fund	Fund	Est Unenc Fund Bal 1/1/2022	Budget Year Estimated Receipt	Total Avail For Expenditures	Budget Year Expenditures and Encumbrances			Estimated Unenc Bal 12/31/2022
					Personal Services	Other	Total	
144	Cable TV	604,283.22	310,000.00	914,283.22	140,000.00	297,589.00	437,589.00	476,694.22
145	Railroad Renovation	216,583.42	30,000.00	246,583.42	10,000.00	80,000.00	90,000.00	156,583.42
147	Airport FAA Grants	555,993.68	300,000.00	855,993.68	-	-	-	855,993.68
148	Airport Land Release Proceeds	-	-	-	-	-	-	-
150	Drug Enforcement Trust	37,035.61	3,500.00	40,535.61	-	-	-	40,535.61
151	Federal Equitable Sharing	24,854.26	-	24,854.26	-	-	-	24,854.26
152	Police Training	23,375.00	-	23,375.00	-	-	-	23,375.00
155	Law Enforcement Trust	30,603.82	5,000.00	35,603.82	-	-	-	35,603.82
158	Sealing of Records	28,967.29	5,000.00	33,967.29	-	-	-	33,967.29
159	Presentence Investigation	173,575.87	30,000.00	203,575.87	-	-	-	203,575.87
160	Computer Legal Research	59,887.76	36,091.00	95,978.76	25,000.00	13,759.00	38,759.00	57,219.76
161	Muni Court Probation Services	60,475.42	110,000.00	170,475.42	80,000.00	30,599.00	110,599.00	59,876.42
162	Court FF&E	89,081.00	-	89,081.00	-	-	-	89,081.00
163	DUI Enforcement	41,008.44	2,500.00	43,508.44	-	-	-	43,508.44
164	Community Service	6,274.18	1,000.00	7,274.18	-	-	-	7,274.18
165	Indigent Driver Alcohol Treatment	168,486.13	40,000.00	208,486.13	70,000.00	70,000.00	70,000.00	138,486.13
166	Indigent Driver Alcohol Monitoring/Interlor	277,332.08	40,000.00	317,332.08	30,000.00	30,000.00	30,000.00	287,332.08
167	Court Clerk Computer	240,348.61	115,000.00	355,348.61	60,000.00	16,272.00	76,272.00	279,076.61
168	Case Management System	95,281.15	47,700.00	142,981.15	-	-	-	92,981.15
169	Court Special Projects	4,332,324.87	-	4,332,324.87	-	-	-	4,332,324.87
170	Coronavirus Relief	1,308.95	2,700,000.00	2,700,000.00	-	-	-	1,308.95
171	American Rescue Plan Act	-	-	-	-	-	-	-
174	Rec Center Administration	-	-	-	-	-	-	-
Total Special Revenue		26,496,583.50	18,307,001.00	44,803,584.50	6,375,000.00	8,721,099.00	15,146,099.00	29,657,485.50
Debt Service Fund Type								
204	Recreation Center Debt Service	-	-	-	-	-	-	-
217	General Bond Retirement	-	-	-	-	-	-	-
418	Special Assessment Bond Retirement	427,016.93	-	427,016.93	-	-	-	427,016.93
Total Debt Service		427,016.93	-	427,016.93	-	-	-	427,016.93
Capital Projects Fund Type								
301	General Purpose Capital	1,556,224.04	292,500.00	1,848,724.04	-	290,288.00	290,288.00	1,558,436.04
304	Parks and Recreation Capital	353.17	-	353.17	-	-	-	353.17
307	Fire Capital Replacement	537,402.70	175,300.00	712,702.70	-	-	-	712,702.70
329	Capital Projects	191,400.00	-	191,400.00	-	-	-	191,400.00
346	Water Capital Improvement	-	-	-	-	-	-	-

City of Medina
Other Funds (Not Reported on Exhibit I or II)

Exhibit III

Fund	Fund	Est Unenc Fund Bal 1/1/2022	Budget Year Estimated Receipt	Total Avail For Expenditures	Budget Year Expenditures and Encumbrances			Estimated Unenc Bal 12/31/2022
					Personal Services	Other	Total	
380	Issue II Projects Fund	629,219.63		629,219.63	-	-	-	629,219.63
381	Street Resurfacing Capital	195,465.16		195,465.16	-	-	-	195,465.16
382	Storm Sewer Capital Replacement			-	-	-	-	-
383	Street Reconstruction Capital			-	-	-	-	-
384	Black Top Resurfacing	68,771.95		68,771.95	-	-	-	68,771.95
385	Curbs and Alleys Capital	18,279.85		18,279.85	-	-	-	18,279.85
386	Federal Highway Administration	0.20		0.20	-	-	-	0.20
388	Computer/Electronic Capital Replacemer	359,147.30	175,300.00	534,447.30	172,000.00		172,000.00	362,447.30
389	Unanticipated Capital Contingencies	1,032,250.26		1,032,250.26	-	-	-	1,032,250.26
428	Special Assessment Projects	20,011.67	27,500.00	47,511.67	10,150.00		10,150.00	37,361.67
	Total Capital Projects	4,608,525.93	670,600.00	5,279,125.93	-	472,438.00	472,438.00	4,806,687.93
	Proprietary Funds							
	Enterprise Funds							
513	Water	2,155,632.64	4,767,450.00	6,923,082.64	1,350,000.00	3,903,667.93	5,253,667.93	1,669,414.71
514	Sanitation	1,788,049.06	3,414,000.00	5,202,049.06	1,250,000.00	2,420,012.00	3,670,012.00	1,532,037.06
546	Water Capital Improvement	454,239.82	691,500.00	1,145,739.82		543,350.00	543,350.00	602,449.82
547	Airport	357,375.12	107,500.00	464,875.12		92,000.00	92,000.00	372,875.12
574	Recreation Center Administration	2,401,479.94	2,776,800.00	5,178,279.94	1,500,000.00	1,312,228.00	2,812,228.00	2,366,051.94
575	MCRC Capital	111,149.47	100,000.00	211,149.47		100,000.00	100,000.00	111,149.47
582	Stormwater Utility	52,134.94		52,134.94		-	-	52,134.94
	Total Enterprise	7,320,120.99	11,857,250.00	19,177,370.99	4,100,000.00	8,371,257.93	12,471,257.93	6,706,113.06
	Internal Service Funds							
616	125 Plan Fund	41,612.75	50,000.00	91,612.75		50,000.00	50,000.00	41,612.75
625	Payroll	405,116.07	15,000,000.00	15,405,116.07		15,106,000.00	15,106,000.00	299,116.07
637	Agency	124,201.71	321,150.00	445,351.71		315,600.00	315,600.00	129,751.71
676	Automotive Mechanics Revolving Fund	75,239.43	420,000.00	495,239.43	350,000.00	110,949.00	460,949.00	34,290.43
	Total Internal Service	646,169.96	15,791,150.00	16,437,319.96	350,000.00	15,582,549.00	15,932,549.00	504,770.96

City of Medina
Other Funds (Not Reported on Exhibit I or II)

Exhibit III

Fund	Fund	Est Unenc Fund Bal 1/1/2022	Budget Year Estimated Receipt	Total Avail For Expenditures	Budget Year Expenditures and Encumbrances		Estimated Unenc Bal 12/31/2022
					Personal Services	Other	
Fiduciary							
Trust and Agency Funds							
722	Water Meter Deposits	60.00		60.00			60.00
723	Developer Deposits	64,318.73	20,000.00	84,318.73	17,000.00	17,000.00	67,318.73
736	Friends of the Cemetery	4,124.33	750.00	4,874.33	750.00	750.00	4,124.33
739	Tricentennial Savings	425.50	200.00	625.50			625.50
741	Utility Deposit	144,813.99	35,000.00	179,813.99	30,000.00	30,000.00	149,813.99
743	Shade Tree Trust	1,411.37	250.00	1,661.37			1,661.37
819	Cemetery Endowment	3,568.38	100.00	3,668.38	1,500.00	1,500.00	2,168.38
820	Cemetery Investment	758,074.22	50,100.00	808,174.22	5,000.00	5,000.00	803,174.22
821	Cemetery Mausoleum	30,232.21	4,600.00	34,832.21			34,832.21
901	Unclaimed Monies	22,596.66	15,000.00	37,596.66			37,596.66
902	Bicentennial Committee	10,787.01		10,787.01			10,787.01
924	Law Library	19,901.55	70,000.00	89,901.55	65,000.00	65,000.00	24,901.55
938	Bid and Performance Bond	49,996.00	105,000.00	154,996.00	100,000.00	100,000.00	54,996.00
939	Ohio Board of Building Standards	9,169.19	15,000.00	24,169.19	14,500.00	14,500.00	9,669.19
975	Planning and Zoning Deposits	312.50		312.50			312.50
Total Trust and Agency		1,119,791.64	316,000.00	1,435,791.64	233,750.00	233,750.00	1,202,041.64
Total for Memorandum Only		40,618,208.95	46,942,001.00	87,560,209.95	10,825,000.00	33,381,093.93	44,256,093.93

City of Medina
General Obligation Debt Outstanding

Exhibit VI

Purpose of Issue	Authority for Outside	Date of Issue	Date Due	Ordinance or Resolution	Serial or Term	Rate of Interest	Amount Outstanding at 1-Jan-22	Amount Required for Principal and Interest Jan 1, 2022-Dec 31, 2022	Amount Receivable from Other Sources to Meet Debt Payments Jan 1, 2022-Dec 31, 2022
Payable from Bond Retirement Fund: INSIDE 10 MILL LIMIT									
Water Improvement - OWDA via County		6/24/2005	1/1/2023		S	2.33% variable	\$ 175,449.42	\$ 122,446.78	Water Enterprise Fund
Water Improvement Refunding		12/29/2010	12/1/2026	193-10	S	variable	\$ 2,045,000.00	\$ 457,350.00	Water Enterprise Fund
Recreation Center - Prepaid Rent Refunding		12/29/2010	12/1/2021	191-10	S	variable	\$ -	\$ -	Rec Ctr Enterprise / Rec Ctr Debt Service
General Capital Improvement		11/28/2012	12/1/2032	165-12	S	variable	\$ 715,000.00	\$ 77,587.50	General Capital Improvement Fund
Water Improvement Refunding		11/28/2012	12/1/2022	157-12	S	variable	\$ 385,000.00	\$ 392,700.00	Water Enterprise Fund
Recreation Center - Prepaid Rent Refunding		11/28/2012	12/1/2022	157-12	S	variable	\$ 500,000.00	\$ 510,000.00	Rec Ctr Enterprise / Rec Ctr Debt Service
Street Improvement - Refunding		6/13/2013	12/1/2031	83-13	S	variable	\$ 5,830,000.00	\$ 741,875.00	Street Improvement Fund
General Capital Improvement - Refunding		6/13/2013	12/1/2031	83-13	S	variable	\$ 1,645,000.00	\$ 212,700.00	General Capital Improvement Fund
Water Improvement - Refunding		6/13/2013	12/1/2031	83-13	S	variable	\$ 655,000.00	\$ 86,000.00	Water Enterprise Fund
TOTAL							\$ 11,950,449.42	\$ 2,600,659.28	

REQUEST FOR COUNCIL ACTION

No. RCA 21-130-6/28

FROM: Keith H. Dirham
DATE: June 17, 2021
SUBJECT: Authorization of payment greater than or equal to \$3,000 in accordance with ORC 5705.41 (D) (1)
Committee: Finance & Council

SUMMARY AND BACKGROUND:

In accordance with ORC 5705.41 (D) (1), I respectfully request that Council pass a resolution authorizing payment to Treasurer State of Ohio (see attached invoice). The 2021 purchase order was not created until 5/24/21.

This request for Council Action shall serve as the Finance Director's certification that there was at the time of the making of this contract and there is at the time of the execution of this certificate a sufficient sum appropriated for the purpose of such contract and in the treasury or in process of collection to the credit of the appropriate fund free from any previous encumbrances.

ORC 5705.41 (D) (1):

Except as otherwise provided in division (D)(2) of this section and section 5705.44 of the Revised Code, make any contract or give any order involving the expenditure of money unless there is attached thereto a certificate of the fiscal officer of the subdivision that the amount required to meet the obligation or, in the case of a continuing contract to be performed in whole or in part in an ensuing fiscal year, the amount required to meet the obligation in the fiscal year in which the contract is made, has been lawfully appropriated for such purpose and is in the treasury or in process of collection to the credit of an appropriate fund free from any previous encumbrances. This certificate need be signed only by the subdivision's fiscal officer. Every such contract made without such a certificate shall be void, and no warrant shall be issued in payment of any amount due thereon. If no certificate is furnished as required, upon receipt by the taxing authority of the subdivision or taxing unit of a certificate of the fiscal officer stating that there was at the time of the making of such contract or order and at the time of the execution of such certificate a sufficient sum appropriated for the purpose of such contract and in the treasury or in process of collection to the credit of an appropriate fund free from any previous encumbrances, such taxing authority may authorize the drawing of a warrant in payment of amounts due upon such contract, but such resolution or ordinance shall be passed within thirty days after the taxing authority receives such certificate; provided that, if the amount involved is less than one hundred dollars in the case of counties or three thousand dollars in the case of all other subdivisions or taxing units, the fiscal officer may authorize it to be paid without such affirmation of the taxing authority of the subdivision or taxing unit, if such expenditure is otherwise valid.

Estimated Cost:

Suggested Funding:

- sufficient funds in Account No. 001-0707-52221
- transfer needed from Account No. _____ to Account No. _____
- NEW APPROPRIATION needed in Account No. _____

Emergency Clause Requested: Yes

Reason: Vendor is waiting for payment.

COUNCIL USE ONLY:

Committee Action/Recommendation:

Council Action Taken:

Ord./Res. Ord. 108-21
Date: 6-28-21

05714

OHIO AUDITOR OF STATE KEITH FABER



Invoice for Services

How to Contact Us:
1-800-282-0370
Monday - Friday 8-4

Customer Number: 06B90

CITY OF MEDINA
KEITH DIRHAM, FINANCE DIRECTOR
132 N. ELMWOOD
MEDINA OH 44256

Account Summary

Previous Balance	\$0.00
Current Charges	\$7,970.40
Payments, Credits	\$0.00
Current Balance	\$7,970.40
Statement Date:	4/30/2021
Payment Due Date:	5/30/2021

Transactions

04/30/2021 BILL 0000000292559 Financial Audit - 06B90MEDI-FA120 \$7,970.40

Now available! Payment by electronic check.
For more information, please visit
<https://eservices.ohioauditor.gov>

PO# 21-1220 Line # 1 = \$7,970.40
 Partial Complete
 Date: 6/1/2021
 Approved: AB

Current	1-30	31-60	61-90	91-120	120+
\$7,970.40	\$0.00	\$0.00	\$0.00	\$0.00	\$0.00

PLEASE RETURN BOTTOM PORTION WITH YOUR REMITTANCE

OHIO AUDITOR OF STATE KEITH FABER



Balance Due: \$7,970.40
Payment Due Date: 5/30/2021
Customer Number: 06B90
Customer Name: CITY OF MEDINA

Make Check Payable To:
Treasurer of State of Ohio

Apply Payment To:

42200 - Financial Audit - 06B90MEDI-FA120

Remit To:

Keith Faber
Auditor of State
Accounts Receivable Office
P.O. Box 711825
Cincinnati, OH 45271-1825

Amount Enclosed:

EXPLANATION OF BILLING RATES and CHARGES

Ohio law requires the Auditor of State to charge public offices the total cost of audits conducted. ORC 117.13

However, the law also provides that, for *local public offices*, AOS audit charges shall be offset based on resources provided by the Ohio General Assembly. Resources currently available to subsidize AOS audit costs are the Local Government Audit Support Fund (LGASF)[1] and the state General Revenue Fund.

For *state agencies*, AOS audit charges are offset to comply with federal cost recovery guidelines by a subsidy provided by the Ohio General Assembly from the state General Revenue Fund.

The current federally approved cost recovery rate for *local public offices* is **\$75.69**. The subsidized AOS rate charged is **\$41.00 per hour**.

The current federally approved cost recovery rate for *state agencies* is **\$96.21**. The current subsidized AOS rate charged to *state agencies* is **\$79.00 per hour**.

For audit services performed by AOS interns, the AOS rate is 50 percent of the otherwise applicable rate.

The current subsidized AOS rates are financially feasible only due to state appropriations made by the Ohio General Assembly from the Local Government Audit Support Fund and the General Revenue Fund.

[1] The Auditor of State's Office proposed establishment of the LGASF in FY 2020 is to avoid an immediate and substantial increase in audit charges for AOS local audit clients..

NOTICE TO DELINQUENT ACCOUNTS

A failure to pay the Auditor of State in full within forty-five days of the payment due date identified on this invoice shall constitute a delinquent account. Failure to make payment will result in the delinquent account being certified to the Ohio Attorney General's Office, Collection Enforcement, for collection under Ohio Revised Code 131.02(A). Alternatively, Ohio Revised Code section 117.13 (D) authorizes the Director of the Office of Budget Management or the county auditor, in order to satisfy certified balances owed to the office of the Auditor of State, to withhold from a public office with delinquent accounts any amounts that are available up to the amount owed by the public office from those funds lawfully payable and due to the public office.

The public office should contact the Auditor of State's Finance Department to make arrangements to pay delinquent balances prior to certification.

Current Invoice Charge Detail

Audit		Hours	Amount	
06B90MEDI-FA120	Simak, Margaret L	3/22/2021 - 4/24/2021	77.90	\$3,193.90
	Ebob, Ako D	3/22/2021 - 4/24/2021	61.00	\$2,501.00
	Smith, Cory C	3/22/2021 - 4/24/2021	48.50	\$1,988.50
	Moore, Andrew J	3/22/2021 - 4/24/2021	6.00	\$246.00
	Young, Lindsey T	3/22/2021 - 4/24/2021	1.00	\$41.00
	BILL0000000292559	194.40	\$7,970.40	

OK
D. Harvey
6-14-2021

REQUEST FOR COUNCIL ACTION

No. RCA 21-131-B/28

FROM: Nino Piccoli -Service Director
DATE: 06-14-2021
SUBJECT: Donation to Medina City

Committee: Finance

SUMMARY AND BACKGROUND:

Respectfully request Council's consideration and authorization to accept a donation of various hand sanitizer equipment, hand sanitizing products and antibacterial wipes from Do It Best Corp. 444 Independence Drive Medina, Ohio 44256. The City intends to share the products with local Governmental agencies as well as entities that may have large public gatherings in the community.

The estimated value of the above-referenced donation is \$150,000.00.

Estimated Cost:
Suggested Funding:
Sufficient funds in Account No.
Transfer needed from Account No.
To Account No.

NEW APPROPRIATION needed in Account No.
Emergency Clause Requested: NO
Reason:

COUNCIL USE ONLY:
Committee Action/Recommendation:

Council Action Taken:

Ord./Res.
Date:

REQUEST FOR COUNCIL ACTION

*10 *
As/Janney
6-14-2021*

NO. RCA 21-132-6/28

FROM: Patrick Patton



COMMITTEE

REFERRAL:

Finance

DATE: June 14, 2021

SUBJECT: Easements for Spring Grove Street Bridge Replacement

In order to complete project #932: Spring Grove Street Bridge Replacements, the City must acquire a total of three (3) easements from property owners. Previously we received and accepted two (2) of those easements. Attached is the third and final easement needed for this project; see below for a summary:

	Property	Acquisition	Value
1	Spring Grove Street PPN 028-19B-16-237; part of Medina City Out Lot No. 5	One (1) sidewalk, water main, storm sewer and drainage easement	\$ 871.64
		TOTAL	\$ 871.64

This requests asks Council to accept the easements submitted herein. Thank you for your cooperation.

ESTIMATED COST: \$ 871.64

SUGGESTED FUNDING: 108-0610-544.11

Sufficient Funds in Account Number:

Transfer Needed from: To:

New Appropriation Account Number:

Emergency Clause Requested: NO

Reason:

COUNCIL USE ONLY:

COMMITTEE RECOMMENDATION:

Council Action Taken:

Ord./Res. Number:

Date:

Sidewalk, Water Main, Storm Sewer and Drainage Easement

KNOW ALL MEN BY THESE PRESENTS:

That in consideration of (EIGHT HUNDRED SEVENTY-ONE and 64/100) Dollars (\$871.64) and other good and valuable consideration recited herein given to BOARD OF EDUCATION OF THE MEDINA CITY SCHOOL DISTRICT & MEDINA CITY SCHOOLS hereinafter "Grantor(s)" by the CITY OF MEDINA, Ohio, hereinafter "Grantee", the receipt of which is hereby acknowledged, the Grantor does hereby grant, bargain, sell, transfer and convey unto the Grantee, its successors and assigns, a sidewalk, water main, storm sewer and drainage easement for the purpose of erecting, constructing, installing and thereafter using, operating, inspecting, maintaining, repairing, replacing or removing a SIDEWALK; PERPETUAL WATERCOURSE WITH A STORM SEWER AND APPURTENANCES; WATER MAIN AND APPURTENANCES under, across, and through certain land of the Grantor(s) situated in the City of Medina, County of Medina and State of Ohio and more particularly described as follows:

Situated in the City of Medina, County of Medina, State of Ohio and being known as part of Medina City Out Lot No. 5 and part of lands conveyed to Board of Education of the Medina City Schools and Medina City Schools by deed dated May 01, 2006 as recorded in 2006OR013105 of the Medina County Recorder's Records, further bounded and described as follows:

Commencing at the Southwest corner of said lands of Board of Education of the Medina City Schools and Medina City Schools, also being the Northwest corner of said MCL 3477 as shown on plat recorded in Plat Volume 17, Page 142 of the Medina County Recorder's Records, also being a point on the Eastern Right-of-Way of Spring Grove Street and the **TRUE PLACE OF BEGINNING** of the parcel herein described;

Thence along the Eastern Right-of-Way of Spring Grove Street, bearing North $00^{\circ}44'09''$ East, a distance of 32.96 feet to a point thereon;

Thence at a right angle and perpendicular to the Eastern Right-of-Way of Spring Grove Street, bearing South $89^{\circ}15'51''$ East, a distance of 12.00 feet to a point;

Thence at a right angle and parallel to the Eastern Right-of-Way of Spring Grove Street, bearing South $00^{\circ}44'09''$ West, a distance of 20.00 feet to a point;

Thence, bearing South $82^{\circ}52'27''$ East, a distance of 25.50 feet to a point on the Northern line of aforesaid MCL 3477, also being a point on a Southern line of aforesaid lands of Board of Education of the Medina City Schools and Medina City Schools;

Thence along the Northern line of said MCL 3477 and a Southern line of aforesaid lands of Board of Education of the Medina City Schools and Medina City Schools, bearing South $75^{\circ}33'54''$ West, a distance of 38.69 feet to the Northwest corner of said MCL 3477, also being a Southwest corner of said lands of Board of Education of the Medina City Schools and Medina City Schools, also being a point on the Eastern Right-of-Way of Spring Grove Street and the **TRUE PLACE OF BEGINNING** containing 0.0115 acres of land, more or less but subject to all legal highways and all covenants and agreements of record.

Bearings are based on an assumed meridian and are used herein to indicate angles only.

This legal description was prepared based on a survey by and/or under the supervision of Douglas S. Jewel P.S. # S-8007 by Cunningham & Associates, Inc. in November 2020.

together with the right of reasonable ingress and egress over the immediately adjacent lands of the Grantor(s) for the purpose and use of said easement. The Grantee covenants and agrees that it will not use said easement for public right-of-way purposes.

As additional consideration for this easement and right-of-way, the Grantee covenants and agrees as follows:

1. Grantee shall repair any and all damage arising from the installation or subsequent repair, maintenance or reconstruction of a PERPETUAL WATERCOURSE; STORM SEWER AND APPURTENANCES; WATER MAIN AND APPURTENANCES.
2. Grantee shall repair any and all damage arising from the installation of a SIDEWALK AND APPURTENANCES. Grantee shall replace any portion of the SIDEWALK AND APPURTENANCES which may become defective for a period of twenty-four (24) months from the time of the original installation.
3. Grantee shall replace any driveway, lawn, shrubbery, or other improvement which may be damaged as a result of construction.
4. Within a reasonable time after completion of construction, and in no event later than forty-five (45) days, Grantee will return the ground to its original condition.
5. Grantee will secure and protect all permanent structures within the construction zone.
6. Grantee will pay for all costs of surveying, recording of documents, filing and transfer fees, escrow costs and title expenses, if any.

Grantor(s) covenant and agrees as follows:

1. Grantor will not install, erect or maintain any structure, fixture or device upon the easement which could in any way interfere with Grantee's use of the easement and right-of-way; however, Grantor retains the right to use the surface of the easement area provided said use does not interfere with the uses granted to Grantee.
2. Upon completion of the twenty-four (24) month warranty period the Grantor will maintain the sidewalk and appurtenances per the City of Medina Codified Ordinance.
3. Authorize the City of Medina, its Engineer, and all other officials, assistants, employees, agents and contractors thereof to enter upon the properties designated as 320 N. Spring Grove Street; Permanent Parcel No. 028-19B-16-237, part of Medina City Outlot 5 with the necessary equipment to remove any obstructions as necessary to allow for the installation of the proposed water main, culvert, headwall and rock rip rap including any trees, tree stumps, brush, vegetation, and landscaping; to complete grading to establish the watercourse; to install the proposed headwall, appurtenances and rock channel protection; to remove a portion of the existing concrete walk and to replace it with concrete in the same location; to install a new water main and appurtenances; to complete grading as necessary; to restore the affected areas with topsoil, seed, fertilizer, and mulch in accordance with the plans and/or specifications as prepared by the City of Medina or its agents during the period of time commencing with the breaking of ground for the above described proposed work and terminating when the work has been completed and/or accepted by the City; and
4. Release the City of Medina, its Engineer, and all other officials, assistants, employees, agents and contractors thereof, from claims of damage, of compensation by reason of the above described work as called for by the said plans and/or specifications provided that the property designated as 320 N. Spring Grove Street; Permanent Parcel No. 028-19B-16-237, part of Medina City Outlot 5 is restored to the condition before construction or as close as reasonably possible in conformance with the plans and/or specifications and/or proposed work described above.

All the terms and conditions of this Easement and Right-of-way shall be binding upon and inure to the benefit of the Grantor(s), the Grantee, their heirs, executors, administrator, successors and assigns.

The grant of this Easement and Right-of-way shall constitute a covenant running with the land for the benefit of the Grantee, its successors and assigns.

IN WITNESS WHEREOF, the undersigned have executed this instrument this 7th day of JUNE, 2021.

Grantor:

Signature: [Handwritten Signature]

Print Name: Robert C. Skidmore

Title: Board President

Company: Board of Education of the Medina City Schools and Medina City Schools

State of Ohio)
County of Medina) SS:

Before me, a Notary Public, in and for said County and State, personally appeared the Grantor, _____, who acknowledged that he/she/they did sign the foregoing instrument and that the same is his/her/their free act and deed.

In testimony whereof, I have set my hand and official seal at Medina, Ohio, this _____ day of _____, 20____.

Notary Signature: _____

Print Name: _____

My Commission Expires: _____

Notary Seal:

This instrument was prepared by:
Gregory Huber, Law Director
City of Medina, Ohio
132 N. Elmwood Avenue
Medina, OH 44256

STATE OF OHIO)
) SS
COUNTY OF MEDINA)

The foregoing instrument was acknowledged before me this 7th day of June 2021 by The Board of Education of the Medina City School District & Medina City Schools by its Board President, Robert C. Skidmore, who acknowledged that he did sign this Power of Attorney, and that it is his free act and deed.

I have signed and sealed this Power of Attorney at Medina, Ohio, this 7th day of June, 2021

James A. Shields, Attorney-At-Law
Notary Public, State of Ohio
My Commission Has No Expiration Date
Sec. 147.03 R.C.

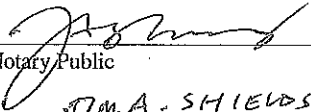

Notary Public
JAMES A. SHIELDS

Printed Name

CUNNINGHAM & ASSOCIATES, INC.
 CIVIL ENGINEERING and SURVEYING
 203 W. LIBERTY ST. MEDINA, OHIO 44256 330-725-5980

LOCATED IN:
CITY OF MEDINA
COUNTY OF MEDINA
STATE OF OHIO

DRAWN BY: KAJ
 DATE: 02/06/2007
 PROJECT NO.: 20-116
 ACAD. INDEX NO.: MCL 126-116 EXH1
 SHEET NO.: 3

SITUATED IN THE CITY
 OF MEDINA, COUNTY OF
 MEDINA, STATE OF OHIO
 AND BEING KNOWN AS
 PART OF MEDINA CITY
 OUT LOT 5

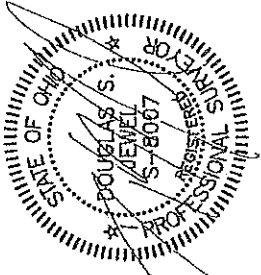

E. NORTH ST. 33'

SPRING GROVE ST. 33' R/W

PART OF OUT LOT 5
 BOARD OF EDUCATION OF THE
 MEDINA CITY SCHOOL DISTRICT
 & MEDINA CITY SCHOOLS
 DOC. NO. 2006OR013105
 05/01/2006

PROPOSED
 EASEMENT AREA
 0.0115 AC.

M.C.L. 3477
 P.V. 17, PG. 142
 KUBASTA HOLDING COMPANY LLC
 DOC. NO. 2005OR002891
 01/17/2003

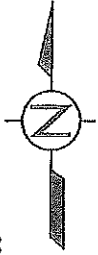

Scale: 1" = 40'
 BEARINGS ARE TO AN ASSUMED MERIDIAN
 AND ARE USED TO DENOTE ANGLES ONLY.

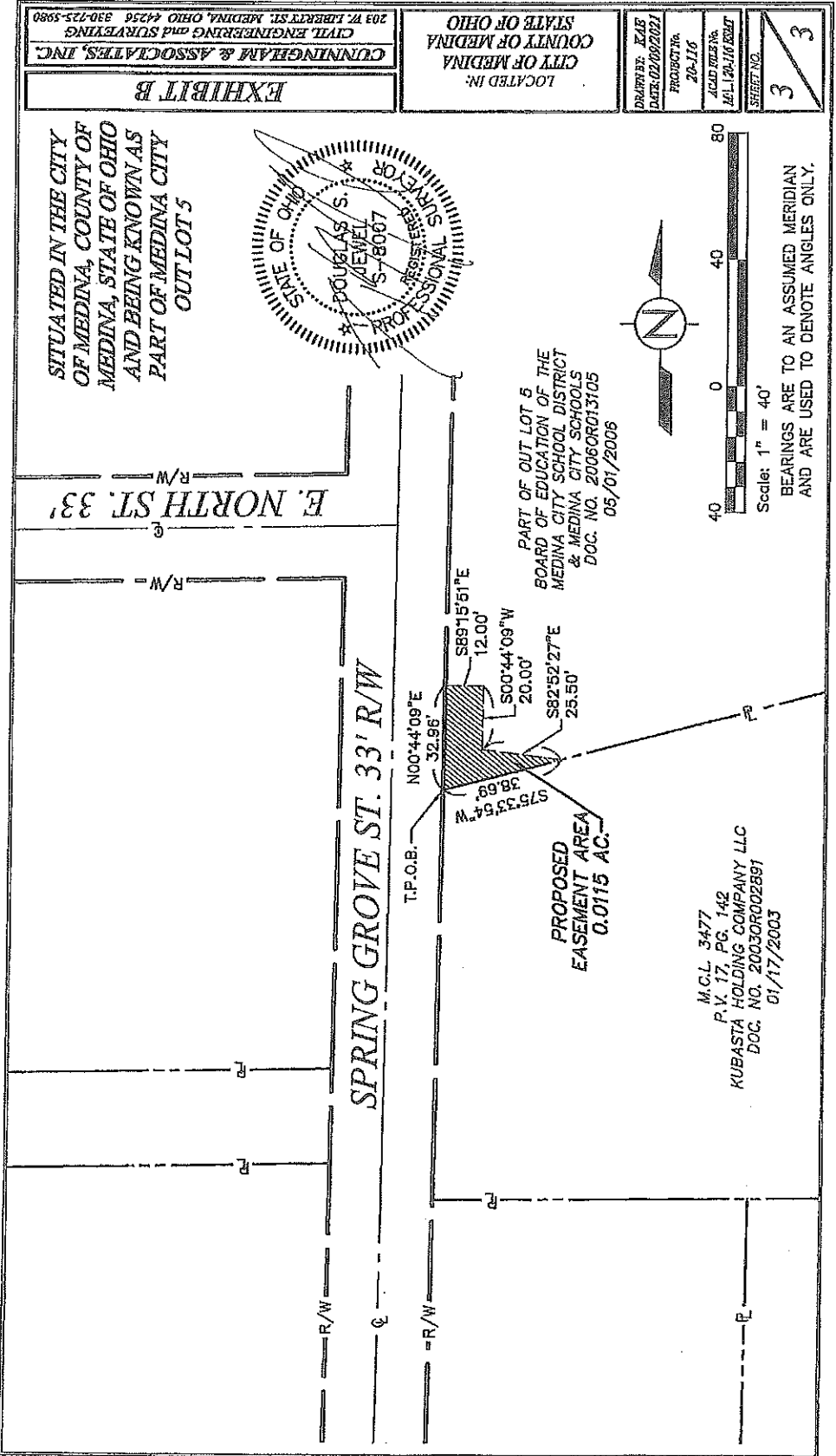

REQUEST FOR COUNCIL ACTION

No. RCA 21-133-6/28

**From: POLICE DEPARTMENT
Chief Edward R. Kinney**

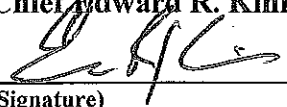

(Signature)

Mayor's Initials:

Committee Finance

Guidelines: See information on back of form

Date: 6/14/21

Subject: Donation from Anonymous Resident

Summary and Background: The Medina Police respectfully requests the approval to accept a \$7,000.00 donation from a Medina resident who wishes to remain anonymous. The donation is given for the growth of drone operations.

Estimated Cost: \$ 0.0

Suggested Funding:

Sufficient Funds in Account:

Transfer Needed From: _____ **To:** _____

New Appropriation Needed: N/A

Account No:

Emergency Clause Requested:

No Yes If yes, reason:

Council Use Only:

Committee Recommendation:

Council Action Taken:

Ord./Res.No:

Date:

REQUEST FOR COUNCIL ACTION

No. PCA 21-134-6/28

FROM: MEDINA MUNICIPAL COURT

Committee: Finance

DATE: JUNE 14, 2021

SUBJECT: FIRSTCOMM – PHONE UPGRADE SYSTEM

SUMMARY AND BACKGROUND:

Medina Municipal Court respectfully requests Council to approve a contract with FirstComm Communications, LLC to upgrade our existing telephone system.

Our existing PBX is an analog telephone system. It is currently in the “end of life” cycle and experiencing intermittent failures.

This upgraded system is a VOIP (voice over IP) and provide the Court with new upgraded technology.

Pending Law Director’s approval

Estimated Cost: \$723.57 per month

Suggested Funding:

- sufficient funds in Account No. 001-0705-52212
- transfer needed from Account No. _____ to Account No. _____
- NEW APPROPRIATION needed in Account No. _____

Emergency Clause Requested: no

Reason: Current lease has expired

COUNCIL USE ONLY:

Committee Action/Recommendation:

Council Action Taken:

Ord./Res.

Date:



Amendment

This is an amendment ("Amendment") to the new Service Order dated _____, 2021 by and between First Communications, LLC ("Company") and Medina Municipal Court ("Customer") located at 135 N. Elmwood Avenue Medina, Ohio 44256. The effective date of this Amendment shall be the later of the dates signed by Customer and Company below.

This Amendment is in addition to the Service Order, RFQ #12497, and all terms incorporated in this Amendment are as defined in the Service Order, including the Master Services Agreement, Terms and Conditions of Business Services, and any other related applicable document, collectively the "Agreement". For good and valuable consideration, the sufficiency of which is hereby acknowledged by the parties, the parties agree to amend the Service Order and Agreement as follows:

Changes to the Terms and Conditions of Business Services Section XI. LEGAL TERMS

D. Indemnification. This Section shall be retitled "Liability for Claims" and replaced in its entirety with the following: "TO THE FULLEST EXTENT PERMITTED BY LAW, YOU AGREE TO BE RESPONSIBLE AND LIABLE FOR CLAIMS OR DAMAGES RELATING TO ANY USE OF THE SERVICES OR EQUIPMENT OR FACILITIES RELATING THERETO, UNLESS DUE TO OUR GROSS NEGLIGENCE OR WILLFUL MISCONDUCT, OR TO YOUR BREACH OF THE AGREEMENT OR YOUR PROMISES. IT IS YOUR RESPONSIBILITY TO CONFORM TO ALL APPLICABLE LAWS OR REGULATIONS AND YOU WILL BE RESPONSIBLE AND LIABLE TO COMPANY AND ITS REPRESENTATIVES FOR CLAIMS ARISING FROM ANY SUCH BREACH AND/OR USE WHETHER LAWFUL OR NOT, INCLUDING THOSE RELATED TO 911 DIALING. YOU ACKNOWLEDGE AND AGREE TO COMPANY'S 911 CHARACTERISTICS AND LIMITATIONS SET FORTH IN THIS AGREEMENT, AND NO SUCH CHARACTERISTICS AND/OR LIMITATIONS SHALL BE DEEMED TO CONSTITUTE NEGLIGENCE, GROSS NEGLIGENCE OR WILLFUL MISCONDUCT OF COMPANY OR ITS REPRESENTATIVES. THIS PARAGRAPH WILL SURVIVE TERMINATION OR EXPIRATION OF THE AGREEMENT."

REMOVE

~~Wherever else indemnification language appears in the Agreement, including indemnify, defend and/or hold harmless language, Customer shall not indemnify Company, provided however, Customer shall be responsible and liable for all such claims, liabilities, losses or damages in such cases."~~

H. Choice of Law/Forum. The word "Fees" shall be removed from this section heading, and the last sentence of this section shall be deleted in its entirety.

Reduced Early Termination Fee

Parties agree that the Early Termination Fees for the Services on this Service Order shall be calculated from the Termination Month and ETF Rate of MRC, as set forth below, times the number of months remaining in the current term, plus the average of the last 3 months usage, as well as any waived installation fees and/or promotional credits (i.e., if Customer terminates the Agreement before the end of the 12th month of the Term, Customer will be charged 100% ETFs, including the usage, waived installation fees, and/or promotional credits as described herein). Customer must provide a 60 day Disconnect Notice as outlined in the applicable terms and conditions found at www.firstcomm.com.

Termination Month	ETF Rate of MRC
0 to 12	100%
13 to 24	75%
25 to 36	50%



Amendment

If there is any conflict between the terms and provisions of the Amendment and the terms and provisions of the Service Order, the Agreement or any prior addenda or amendments thereto, the terms and provisions of this Amendment shall govern. Except as specifically set forth herein, all other provisions of the Service Order and the Agreement and any prior addenda or amendment thereto shall remain in full force and effect and be binding upon the parties in accordance with their terms.

The undersigned hereby represent and warrant that they are duly authorized to execute this Amendment and have fully read and understand the terms and conditions.

Medina Municipal Court

First Communications, LLC

Authorized Signature: _____

Authorized Signature: _____

Printed Name: _____

Printed Name: _____

Title: _____

Title: _____

Date: _____

Date: _____



Order Type: NEW

Customer Information

Company Name : Medina Municipal Court

Sales Executive Information

Sales Executive : Faber, Ronald - 1008A

Phone : (330) 436-5020

E-Mail : rfaber@firstcomm.com

Billing :

Fed. Tax ID Number : _____

Federal Tax Exempt ID : _____

State Tax Exempt ID : _____

Existing Account Number if applicable : _____

Parent Account Number if applicable : _____

Contract:

Contract Term (yrs) : 3

135 N Elmwood Ave, Medina, OH, 44256 (1)

UCaaS					
UC Packages	Unit Price	QTY	Monthly	One-Time	
UC Standard	\$11.99	40	\$479.60	\$0.00	
Equipment					
Equipment	Unit Price	QTY	Monthly	One-Time	
OBI 300 Voice Adapter - Faxing & UC Standard	\$7.99	3	\$23.97	\$0.00	
UC Phones - Yealink					
UC Phones - Yealink	Unit Price	QTY	Monthly	One-Time	
Yealink T54W Equipment Rental	\$5.50	40	\$220.00	\$0.00	
Usage					
Usage	Unit Price	QTY	Monthly	One-Time	
IP PBX Unlimited Local + LD	\$0.00	40	\$0.00	\$0.00	
Training					
Training	Unit Price	QTY	Monthly	One-Time	
Phone & Feature / Portal Training- Webinar Included up to 2 hours	\$0.00	1	\$0.00	\$0.00	
Site Total			\$723.57	\$0.00	
Order Totals			\$723.57	\$0.00	

Contact Type 1: Service Address Contact

Name : _____

Title : _____

Phone : _____

E-Mail : _____

Responsible Authorized Party Contact :

Name : _____

Customer Management Portal Login ID : _____

Title : _____

Phone : _____

E-Mail : _____

Voice Vendor :

Name : _____

Title : _____

Phone : _____

E-Mail : _____

Data Vendor :

Name : _____
 Title : _____
 Phone : _____
 E-Mail : _____

By signing this Service Order, Customer is ordering the Services set forth herein and agreeing to the following terms and conditions applicable to the specified Services, all of which are incorporated herein by reference as if fully set forth herein and which form an integral part of Customer's Agreement with Company: (i) Master Services Agreement; (ii) applicable Service Terms and/or Service Level Agreement, if any; (i) First Communications, LLC ("Company") Terms and Conditions of Business Services, which can be found at www.firstcomm.com ("T&Cs"); and (iv) any applicable rates, tariffs and/or price/service guides, which may also be found at www.firstcomm.com. Defined terms used herein and not defined shall have the meanings given to them in the T&Cs. Customer agrees to pay for all Services ordered or otherwise used or provided, including, but not limited to, applicable federal, state, local use, excise, sales, or privilege taxes, duties or similar liabilities, surcharges, and any other fees charged by Company, including those in the applicable tariff and/or rate guide. Customer acknowledges and agrees that it has read and agrees to be bound by this Service Order and all applicable agreements and terms described above. Customer authorizes Company to obtain any credit information and/or customer proprietary network information (CPNI) necessary to provision Services and to establish or maintain Customer's account and acknowledges that provision of Services hereunder is subject to a Customer credit check satisfactory to Company in its sole discretion; and hereby also authorizes the release of such information by any third parties to Company. Customer may be required to complete Company's Credit Application to commence the required credit check, and if required, but Customer fails to do so, Customer will be in breach of the Agreement. Customer understands that number and/or IP assignments are not guaranteed and the Agreement is not conditioned upon availability or provisioning of any such number/IP assignment. Customer has provided, and upon request will provide, Company with a valid Letter of Authorization, Letter of Agency, and/or Change of Responsible Organization for all applicable Services ordered. Any changes in the Services ordered (e.g., adding/deleting/replacing lines, equipment or licenses, increasing bandwidth, length of term, software installations or upgrades etc.) will alter the pricing set forth herein, and all such changes shall be subject to the terms of the Agreement under this Service Order regardless of whether they are made by Amendment or otherwise changed in connection with provisioning or delivery of the Services. The parties agree that any change within ten percent of the value signed for herein by Customer will be binding upon Customer and will not be deemed a material change. Customer is responsible for identification and payment of any termination fees to any third party that may apply when switching to Company's Services. By signing below, the undersigned represents that he/she is authorized to enter into the Agreement on behalf of Customer.

Agreed to on behalf of CUSTOMER by:

Name: _____
 Title: _____
 Authorized Signature: _____
 Date: _____

Agreed to on behalf of FIRST COMMUNICATIONS, LLC by:

Name: _____
 Title: _____
 Authorized Signature: _____
 Date: _____



This Master Services Agreement ("MSA") is made by and between First Communications, LLC, with offices at 3340 West Market Street, Akron, OH 44333 ("First Communications"), and Medina Municipal Court ("Customer"). Each party may be referred to herein as a "Party" or collectively as the "Parties." This MSA sets forth the general terms and conditions governing Customer's purchase of Services from First Communications. Defined and/or capitalized terms used in this MSA and not otherwise defined herein shall have the meanings given to them in First Communications' Terms and Conditions of Business Services ("T&Cs") posted on First Communications' website www.firstcomm.com from time to time, which are applicable to all Services provided by First Communications and form an integral part of the Agreement between the Parties.

1. SERVICES; SERVICE ORDERS

1.1 Customer may submit requests for Services hereunder upon or after execution of this MSA by submission of an executed Service Order in the most current form of Service Order that is designated for Service requests by First Communications at the time of such order ("Service Order"). The Service Order, together with the T&Cs and applicable individual Service Terms (if any), shall set forth the Term, pricing, service location(s) and additional terms and conditions specific to the requested Services. Except to the extent expressly set forth in a fully executed Amendment between the parties, all terms and conditions set forth in the Agreement shall control. Customer agrees that any provisioned or delivered changes, including additions, deletions or replacements, to the Service ordered (such as adding/deleting/replacing lines, equipment or licenses, increasing bandwidth or licenses, changing length of Term or installing or upgrading software) arising out of such ordered Service shall be governed by the Agreement.

1.2 A Service Order shall be deemed accepted by First Communications upon execution of such Service Order by a duly authorized representative of First Communications. First Communications shall have no obligation to provide and no liability for Services requested in any Service Order that First Communications has not accepted. First Communications reserves the right to add or delete Service offerings under this MSA and to increase prices to be charged to Customer for Services provided during the Term; provided, however, any changes on Service Orders already accepted shall be only in accordance with the T&Cs and/or applicable Service Terms.

1.3 First Communications may elect to offer an electronic or automated method for submitting Service Orders now or in the future and may advise Customer if such order entry system becomes available in the future, in which case an order for Service submitted by such First Communications approved electronic or automated method shall be deemed a Service Order under the Agreement. Customer understands and agrees that any online click through order for Cloud IP PBX Service shall be deemed a Service Order under the Agreement and all terms and conditions of the Agreement shall be binding on Customer with respect to such click through Service Order.

1.4 Service Level Goals for applicable Services are outlined in separate Service Terms or Service Level Agreements particular to each Service (each, an "SLA") and posted on First Communications' website www.firstcomm.com. First Communications may change the form of the SLA at any time for any Services and Service Orders not yet executed by the Parties. Each SLA applies only for the specific Service as defined in that individual SLA. In the event of performance issues resulting in the relevant Service Level Goal not being met, eligible Customers will receive a service credit against the applicable Affected Service MRC in accordance with SLA terms and conditions.

2. TERM AND TERMINATION

2.1 Unless earlier terminated as provided in the Agreement, this MSA shall be in effect for as long as the Term of any accepted Service Order(s), or Amendments thereto or hereto, or otherwise for as long as First Communications shall provide Services to Customer. Each Service Order placed under the Agreement shall have its own Term as indicated on such Service Order. At the valid expiration or termination of the initial Term plus any renewal Term of the individual Service Order(s), if First Communications continues to provide Service under such Service Order regardless of such expiration or termination, the applicable Service Order shall remain in effect on a month-to-month basis pursuant to the terms of the Agreement until thereafter non-renewed and/or terminated in accordance with the T&Cs by either Party. If Customer continues to receive Service after the effective date of any prior termination/disconnect notice, Customer will be deemed to have waived the prior termination/disconnect request and must submit a new termination/disconnect notice thereafter in accordance with the timeframes and terms set forth herein and in the T&Cs.

2.2 In all cases where Customer desires to non-renew or terminate Services, including, without limitation, those being provided on a month-to-month basis, Customer shall provide First Communications with at least 60 days prior written notice that Customer is disconnecting or terminating Services. If Customer terminates/disconnects this MSA, a Service Order and/or any Service(s) prior to the end of the applicable Term, or if First Communications terminates this MSA, a Service Order and/or any Service(s) pursuant to a Customer default under the Agreement, Customer shall be subject to an Early Termination Fee.

3. BILLING AND PAYMENT; CREDIT APPROVAL

3.1 Billing for Services shall commence upon the date Service is first made available to Customer. First Communications shall provide Customer with a monthly invoice and all amounts due First Communications shall be payable in full within 30 days from the date of invoice. First Communications may charge interest at the rate of 1.5% per month, not to exceed the highest lawful rate, on delinquent amounts, without prejudice to its other rights under the Agreement in the event of delinquent payment. Customer must deliver written notice of any billing dispute together with all supporting documentation to First Communications within 60 days from the date of the original invoice, otherwise such invoice shall be deemed correct. In the event of a billing dispute, Customer shall timely pay all undisputed amounts including any undisputed portion of a disputed invoice. Customer will receive a monthly paper invoice from First Communications at a charge of \$10 per month unless it elects the paperless billing option by submitting the Paperless Invoice Authorization Form with the Agreement.

3.2 Provision of all Service Orders are subject to a Customer credit check, and at its sole option upon written (including via e-mail) or verbal notice to Customer, First Communications may require a Customer deposit or other assurance of performance or financial wherewithal prior to initiation of any provisioning or installation of Service, or may promptly terminate the Agreement and/or any Service Order without liability to First Communications, including, without limitation, any termination due to Customer's failure to provide the required deposit or other assurance of performance or financial wherewithal. Customer agrees that it must complete First Communications' Credit Application to commence the required credit check and failure to do so will be deemed to be a breach of the Agreement. First Communications shall refund all or a portion of a deposit paid to First Communications if First Communications determines in good faith, based on Customer's credit rating and payment history, that such deposit is no longer necessary to ensure timely payment. Refund of all deposit monies remaining with First Communications shall occur upon termination or expiration of the Agreement and all associated Service Orders, less any amounts that may be due from Customer hereunder.

4. TAXES AND REGULATORY FEES

Customer shall be responsible for the proper and timely payment and reporting of, and shall hold First Communications harmless from and against, applicable federal, state, local and other sales, use, excise, regulatory or other taxes, fees, charges or surcharges (other than taxes imposed on First Communications' net income, capital or net worth) to taxing authorities that are assessed, related to or due by reason of the provision of Services by First Communications to Customer under the Agreement, including any penalties and interest thereon. If applicable, Customer shall keep on file with First Communications copies of its current tax exemption certificates, and in any event, shall provide such certificates annually to First Communications. All federal, state, local or other taxes determined by First Communications to be due on the Services provided under the Agreement shall be charged to Customer and be due and payable according to the terms of the Agreement.

5. APPLICABLE LAWS

5.1 The Agreement is subject to all applicable federal, state, local or other laws, and regulations, rulings and orders of governmental agencies, including, but not limited to, the Communications Act of 1934, as amended, the Telecommunications Act of 1996, the Rules and Regulations of the Federal Communications Commission ("FCC"), First Communications' applicable tariffs or price guides, if any, and the receipt and continuance of any required approval or authorization by First Communications from the FCC or any governmental body with authority over the Services to be provided. The Services provided by First Communications are subject to the condition that they will not be used for any unlawful or unauthorized purposes. Customer agrees that it is solely responsible for determining whether any Services, including applications, features, data or third party services relating thereto, or any use thereof comply with laws, standards, regulations and policies applicable to Customer's business or industry, including without limitation those relating to privacy, data protection, financial standards, personally identifiable information, personal health information, consumer protection and/or telemarketing, and ensuring compliance therewith.

5.2 Either Party may terminate its obligations under the Agreement and/or any Service Order without liability if ordered to do so by the final order or ruling of a court or other governmental agency or if any order or ruling would make it impossible for either Party to carry out its obligations under the Agreement or such Service Order. In the event Customer engages in any unlawful or unauthorized use of the Services, or in the event Customer violates any laws, rules or orders of the FCC, other regulatory authority or a court of competent jurisdiction, First Communications may, in its discretion, take such action as is necessary to comply with applicable law or regulation, including but not limited to, termination of the Agreement, the applicable Service Order and/or the Services to Customer in whole or in part.

6. DISPUTE RESOLUTION; CHOICE OF LAW AND FORUM

6.1 The Parties agree to use the dispute resolution procedures set forth in the T&Cs with respect to any claim, dispute or other controversy arising out of or relating to the Agreement, except for the following types of claims, disputes or controversies: (a) suits for preliminary injunctions or temporary restraining orders; (b) suits to compel compliance with the dispute resolution processes; or (c) billing or payment collections matters or claims initiated by First Communications. In any court proceeding to enforce the Parties' agreement to arbitrate, the only issues to be determined shall be the existence of the agreement to arbitrate in the T&Cs, whether the issue is subject to arbitration and the failure of one Party to comply with that arbitration agreement. These issues shall be decided by the court without a jury. The Parties agree that there shall be no appeal of an order compelling arbitration except as part of an appeal concerning confirmation of the decision of the arbitrator.

6.2 This MSA and the Agreement shall be construed and enforced in accordance with, and the validity and performance hereof shall be governed by, the laws of the State of Ohio without regard to its conflict of laws principles. The Parties agree that Akron, Ohio will be the exclusive jurisdiction for any claim, dispute or other controversy that may arise between the Parties. Each Party consents to personal jurisdiction and venue in Akron, Ohio and waives any objection based on inconvenient forum. Notwithstanding anything to the contrary set forth herein, each Party irrevocably waives any right to trial by jury in connection with any claim, dispute or other controversy.

7. ENTIRE AGREEMENT; SEVERABILITY

The Agreement (including all fully executed Service Order(s) and Amendments hereto and thereto) constitutes the entire understanding between the Parties relating to all Services provided by First Communications to Customer and correctly sets forth the rights, duties and obligations of each Party to the other; provided, however, that the Agreement shall not affect or modify the terms or applicability of any other agreement between the Parties regarding subject matter other than Services provided by First Communications to Customer. Any prior or contemporaneous agreements, promises, negotiations or representations regarding the subject matter of the Agreement not expressly set forth in the Agreement are of no force or effect. No alteration, modification or variation of the terms of any provision shall be valid unless made in a written Amendment and signed by a duly authorized representative of First Communications and Customer. In the event that any one or more of the provisions of the Agreement shall for any reason be held to be invalid or unenforceable, the remaining provisions of the Agreement shall be unimpaired and shall remain in effect and be binding upon the Parties. Each Party hereby represents and agrees that it has read and understands the T&Cs and any applicable Service Terms for additional provisions of the Agreement binding on the Parties, including, without limitation, those relating to Charges, Term, Conditions of Use, Acceptable Internet Use Policy, 911/E911 Services, Indemnification, Warranty Disclaimer and Limitation of Liability.

8. BINDING EFFECT; ASSIGNMENT; WAIVER

This MSA and the Agreement shall be binding upon and inure to the benefit of the Parties hereto and their respective successors and permitted assigns. Customer may not assign the Agreement or any rights or obligations thereunder without First Communications' prior written consent. Any provision of this Agreement may be waived in writing at any time by the Party that is entitled to the benefit of such provision. No failure nor delay by a Party in exercising any right, power or privilege under the Agreement will operate as a waiver of such right, power or privilege, and no single or partial exercise of such right, power or privilege shall preclude any other or further exercise of such right, power or privilege or the exercise of any other right, power or privilege.

9. CONSTRUCTION AND INTERPRETATION; CONFIDENTIALITY

The Parties hereby waive any rule requiring construction or interpretation against the drafter with respect to the Agreement, including, without limitation, any Service Order under this MSA. With respect to any interpretation hereof and thereof, the Agreement shall be deemed to be drafted by both parties by mutual effort and agreement. The Parties agree that this MSA and any Service Order hereunder shall be deemed and will be treated as confidential information pursuant to the T&Cs.

10. COUNTERPARTS; ELECTRONIC SIGNATURES

Acceptance of this MSA and any Service Order hereunder is contingent upon acceptance by a representative of First Communications duly authorized to execute this MSA and/or the Service Order. Documents requiring signature as part of the Agreement may be executed in separate counterparts, each of which, when so executed, shall be an original, but all such counterparts which shall together constitute one and the same Agreement. Facsimile and electronic signatures, including any click through ordering portal or DocuSign confirmation, shall be deemed and will be treated as an original signed Agreement or counterpart, as applicable.

The undersigned each hereby represent and warrant that he/she is duly authorized to execute this MSA and any Service Order hereunder, has fully read and understood the terms and conditions of the Agreement and accepts the Agreement on behalf of the respective company identified below.

IN WITNESS WHEREOF, the Parties have executed the Agreement as of the date set forth below.

Medina Municipal Court

First Communications, LLC

Authorized

Authorized

Signature: _____

Signature: _____

Printed

Printed

Name: _____

Name: _____

Title: _____

Title: _____

Date: _____

Date: _____



As a First Communications customer, you are eligible to sign up for our Paperless Billing option. Please select the option you wish and sign below. If you do not select an option and/or sign below, you will receive a paper invoice, which does require a \$10.00 fee that will appear on your monthly invoice.

- Yes! I want to *save \$10 a month* by receiving a Paperless Invoice.
- No, I would like to receive a Paper Invoice.

Billing Contact Name

Title

Email Address

Customer Signature

Date

How it works:

- ❖ An email will be sent to your billing email address with a Temporary Username and Password
- ❖ You can now log on to <https://www.firstcomm.com/customer-login/> to view your invoice, payment information, call detail and more
- ❖ When your invoice is ready for viewing, you will receive an email notification
- ❖ Make payments *even simpler* by signing up for First Communications Automatic Payment Feature

*Charges and fees may be subject to change. Please see www.firstcomm.com for more information.

OK
Approved
6-16-2021

REQUEST FOR COUNCIL ACTION

No. RCA 21-135-6/28

FROM: Kimberly Marshall

Committee Finance

DATE: June 16, 2021

SUBJECT: Amend Job Creation Grant Agreement – Kraft Werks Engineering, LLC JCG-18

SUMMARY AND BACKGROUND:

Ordinance 103-18 authorized the Mayor to enter into a Job Creation Grant Agreement with Kraft Werks Engineering, LLC for the company to establish a new business in the City of Medina at 935 Heritage Dr., and create 45 full-time jobs and \$3,000,010.00 in new payroll

During our Job Creation Grant monitoring this year, Kraft Werks Engineering discovered that the annual payroll and number of jobs estimated in the initial application had been miscalculated.

Kraft Werks Engineering, LLC has requested their grant agreement be amended to reflect the annual payroll of \$2,000,100 and 32 full time positions. Please see attached letter from Kraft Werks Engineering, LLC.

The amended agreement will reduce the grant term from 6 years to 5 years.

Per our grant guidelines, the company still has one year left to hit payroll and job goals. We will monitor it again in 2022 accordingly.

Suggested Funding:

- Sufficient funds in Account No.
- Transfer needed from Account No.
to Account No.
- NEW APPROPRIATION needed in Account No.

Emergency Clause Requested:

Reason:

COUNCIL USE ONLY:

Committee Action/Recommendation:

Council Action Taken:

**Ord./Res.
Date:**

PLEASE REVIEW THE EMPLOYMENT AND PAYROLL NUMBERS FOR CONSISTENCY WITH YOUR APPLICATION FORM. THESE NUMBERS WILL BECOME YOUR COMPANY'S COMMITMENT TO THE CITY OF MEDINA.

EXHIBIT A

GRANT# JCG18-Kraft Werks Engineering LLC-18

(Administrative Only)

JOB CREATION GRANT AGREEMENT

This Agreement made and entered into by and between the CITY OF MEDINA, OHIO, a municipal corporation, with its main offices located at 132 North Elmwood Avenue, Medina, Ohio 44256 (hereinafter referred to as "Medina") and **Kraft Werks Engineering LLC** with its main offices located at **935 Heritage Drive, Medina, Ohio 44256** (hereinafter referred to as "The Company"), and is dated as of _____.

WHEREAS, the "Company" has requested an amendment to Exhibit A grant agreement as revised below:

WITNESSETH:

WHEREAS, Medina has encouraged the creation and retention of new job opportunities throughout the City of Medina; and

WHEREAS, "The Company" is desirous of **establishing a new business located at 935 Heritage Drive, Medina, Ohio** to create **32** new full time employment opportunities (hereinafter sometimes referred to as the "PROJECT") within the boundaries of the City of Medina, provided that the appropriate development incentives are available to support the economic viability of said PROJECT; and

WHEREAS, the Council of the City of Medina, Ohio by Ordinance No. 154-07 adopted September 25, 2007 created the Job Creation Grant Program pursuant to Article XVIII, Section 3 and Article VIII, Section 13 of the Ohio Constitution; and

WHEREAS, the City of Medina, having the appropriate authority for the stated type of program, is desirous of providing **"The Company"** with incentives available for the development of the PROJECT; and

WHEREAS, **"The Company"** has submitted a proposed Agreement application (herein attached as Exhibit A1) to the City of Medina (said application hereinafter referred to as "Application"); and

WHEREAS, **"The Company"** has remitted the required application fee of \$ 500.00 made payable to the City of Medina; and

WHEREAS, the Business Development Committee of the City of Medina has investigated the application of **"The Company"** and has recommended the same to Medina City Council on the basis that **"The Company"** is qualified by financial responsibility and

business experience to create employment opportunities in the City of Medina and improve the economic climate of Medina; and

WHEREAS, the Business Development Committee of the City of Medina has investigated the request of "The Company" to amend the agreement and has recommended the same to City Council on the basis that "The Company" is qualified by financial responsibility business experience and have created the employment opportunities in the City of Medina and improved the economic climate of Medina and;

NOW, THEREFORE, in consideration of the mutual covenants hereinafter contained and the benefit to be derived by the parties from the execution hereof, the parties herein agree as follows:

1. Description of the Project.

- A. "The Company" shall acquire a building located at 935 Heritage Drive, Medina, Ohio for the purpose of manufacturing. This project will include significant investments for land and building acquisition, building improvements, machinery & equipment and inventory.

2. Project Investment.

- A. The PROJECT will involve a total investment, plus or minus 10%, by the Property Owner of \$4,000,000(dollars).
- B. The PROJECT will involve a total investment, plus or minus 10%, by "The Company" as follows:

1. New Machinery and Equipment	\$ 800,000
2. Improvements to Existing Buildings	\$ 50,000
3. Land/Building Acquisition	\$ 1,920,000
4. Inventory	\$ 1,200,000
5. Furniture & Equipment	\$ 30,000
TOTAL	\$4,000,000

- C. Occupancy of the building will begin approximately **May 24, 2018**.

3. Job Creation and Retention.

- A. "The Company" shall create in the City of Medina within a time period not exceeding **36** months after the occupation of the aforesaid facility, the equivalent of **32** new full-time permanent job opportunities in the City of Medina.

- 1) "The Company" schedule for hiring permanent full time employees is as follows:

<u>Year</u>	<u>Number of Jobs New to Medina</u>
2019	27
2020	3
2021	2

- B. The job creation period begins approximately July 2018 and all jobs will be in place by December 31, 2021.
- C. The Company currently has 0 employees at the project site. The Company currently has 0 employees in the City of Medina. The Company will create 32 full-time permanent employees in the City of Medina in the State of Ohio.
- D. The increase in the number of employees new to the City of Medina will result in approximately **\$2,000,100.** of additional annual payroll in the City of Medina when the projected maximum employment level is achieved.

4. Issuance of Grant.

- A. The City of Medina hereby grants a Job Creation Grant based upon the creation of new payroll and jobs in the City of Medina, and the implementation of the PROJECT, according to the schedules contained herein in Section 4(C).

<u>Years</u>	<u>Amount of Grant as a Percentage Of Payroll Taxes New to Medina</u>
5	40%

Funding for the grant issued herein shall only be from the following non-tax revenue sources: interest income, permit fees, activity fees, service charges, and tax incentive application and monitoring fees.

- B. For purposes of calculating the amount of the grant, the new payroll upon which the grant is based may not exceed 25% above the maximum payroll projected in Section 3(D) above. The grant amount shall be based on the current 1.25% income tax rate. The maximum grant amount in any year shall be **\$12,500.63 (maximum NEW PAYROLL projection x 125% X 1.25% x 40% of grant)**
- C. To receive a grant in any given year, **“The Company”** must retain full time permanent jobs existing in Medina as per the grant Agreement.

- (1) If **“The Company”** does not achieve at least 90% of new payroll projections, **“The Company”** shall receive reduced incentives according to the schedule below:

<u>% of New Payroll Projection Achieved</u>	<u>Amount of Grant as a Percentage of Payroll Taxes New to Medina</u>
90-100%	full grant
85-89%	reduce grant by 5% (Ex.: 40% grant reduced to 35%)
80-84%	reduce grant by 10% (Ex.: 40% grant reduced to 30%)
75-79%	reduce grant by 15%
Less than 75%	no grant for that year; and

- (2) If **“The Company”** fails to meet 75% of new payroll **or** new employment projections in any given year, the grant shall not be awarded for that year.
- (3) If **“The Company”** has multiple locations in the City of Medina and new employment and new payroll projections are met at any combination of locations in the City of Medina, **“The Company”** will receive its annual grant payment.
- (4) New payroll is defined as that amount in Section 3(D) above.

5. Grant Payments.

A. Initial Grant Payment.

- (1) Year 1 projections must be met by December 31, 2019. The initial grant payment shall be made by approximately June 30th, 2022, provided that **“The Company”** files its Reconciliation of City Income Tax Withheld Form S-W3 by February 28, 2022, and reconciliation is confirmed by the City of Medina Finance Department.
- (2) If the project start or occupancy of the project facility is delayed, Year 1 may be extended to the following year and the Year 1 projections deadline adjusted accordingly, upon written request by **“The Company”** to the Economic Development Director, provided that the extension is approved by the Economic Development Director with notice to the Business Development Committee.
- (3) If the project or occupancy of a project facility begins in the third or fourth quarter of the year and **“The Company”** is not able to meet its Year 1 projections by December 31st of that year, Year 1 will be considered the first full year of occupancy, and the first grant payment will occur in the year following the first full year of the project or occupancy of the project facility.

B. Timing of Annual Grant Payments. Annual grant payments shall be made by June 30th of the following year, provided that **“The Company”** files its Reconciliation of City Income Tax Withheld Form S-W3 by February 28th and reconciliation is confirmed by the City of Medina Finance Department. If **“The Company”** requests an extension for filing of its S-W3 form, the City of Medina shall make the grant payment within three months of the extended filing date. It is the responsibility of **“The Company”** to advise the Economic Development Director of the filing extension.

C. Use of Grant Payments. Grants shall be allocated by **“The Company”** for land acquisition, building acquisition, purchase of machinery/equipment, purchase of furniture/fixtures, and/or other non-construction related and non-installation related costs of the project.

6. Payment of Taxes and Filing Reports and Returns. **“The Company”** shall pay all taxes and shall file all tax reports and returns as required by law. If **“The Company”** fails to

pay such taxes or file such returns and reports, all incentives granted under this Agreement are terminated beginning with the year for which such taxes are charged or such reports or returns are required to be filed and thereafter.

7. Information for Annual Review. **"The Company"** shall timely provide to the City of Medina any information reasonably required by the City of Medina to evaluate **"The Company's"** compliance with the Agreement.

8. Maintenance of Grant.
 - A. Medina shall perform such acts as are reasonably necessary or appropriate to effect, claim, reserve, and maintain incentives granted under this Agreement including, without limitation, joining in the execution of all documentation and providing necessary information to maintain the incentives granted hereunder.

 - B. If for any reason the Job Creation Grant Program is discontinued, entitlements granted under this Agreement shall continue for the number of years specified under this Agreement, unless **"The Company"** materially fails to fulfill its obligations under this Agreement and Medina terminates or modifies the incentives granted under this Agreement.

9. Certification as to Payment of Taxes. **"The Company"** certifies that at the time this Agreement is executed, **"The Company"** does not owe any delinquent real or tangible personal property taxes to any taxing authority of the State of Ohio, and does not owe delinquent taxes for which **"The Company"** is liable under Chapter 5733, 5735, 5739, 5741, 5743, 5747, or 5753 of the Ohio Revised Code, or, if such delinquent taxes are owed, **"The Company"** currently is paying the delinquent taxes pursuant to an undertaking enforceable by the State of Ohio or an agent or instrumentality thereof, has filed a petition in bankruptcy under 11 U.S.C.A. 101, et seq., or such a petition has been filed against **"The Company"** For the purposes of the certification, delinquent taxes are taxes that remain unpaid on the latest day prescribed for payment without penalty under the chapter of the Revised Code governing payment of those taxes.

10. Non-Discrimination Hiring. Medina has developed a policy to ensure recipients of Job Creation Grants practice non-discriminatory hiring in its operations. By executing this Agreement, **"The Company"** is committing to following non-discriminatory hiring practices acknowledging that no individual may be denied employment solely on the basis of race, religion, sex, disability, color, national origin, or ancestry.

11. Transfer and Assignment. This Agreement is not transferable or assignable without the express, written approval of Medina. The City of Medina acknowledges that it would be unreasonable to withhold such consent in the event of a proposed transfer or assignment to any parent, subsidiary or affiliate of **"The Company"** or to any third party so long as with respect to all or any of such proposed transfers or assignments, the proposed transferee or assignee adequately and sufficiently demonstrates to the

City of Medina, to the City of Medina's reasonable satisfaction, its financial ability, business experience and intentions to continue its operations of the Facility and Project in a manner similar to that of **"The Company"** in all pertinent respects.

12. Termination or Modification of Incentives.

- A. If **"The Company"** fails to meet 75% of new payroll or new employment projections in any given year, the grant shall not be awarded for that year.
- B. If **"The Company"** fails to meet 75% of new payroll or new employment projections for three consecutive years, this Agreement shall be terminated by the City of Medina.
- C. If the project does not proceed as specified in Section 5(A)(1) of the Agreement or within the approved one year extension period, the City of Medina may terminate the Agreement upon recommendation of the Business Development Committee.
- D. If **"The Company"** fails to submit required information and/or reports as set forth in Section 7 above, the City of Medina may terminate or modify this Agreement and deny or modify future grants heretofore granted from the date of **"The Company's"** breach or default.

In the case as provided in this Subsection D, the City of Medina's termination or modification of this Agreement may be instituted only if **"The Company"** fails to cure any breach of any term of this Agreement as determined by the City of Medina within ten (10) days of receiving written notice of such failure from the City of Medina or, if cure of the breach cannot be completed within ten (10) days, if **"The Company"** has not made a good faith start of the cure, and/or not diligently pursued same.

- E. Nothing contained in Sections 12(A), 12(B), 12(C), or 12(D) shall permit the City of Medina to recapture or otherwise deny **"The Company"** the benefit of a grant in respect of any period prior to the date of such termination or modification by the City of Medina.
- F. The City of Medina may terminate or modify this Agreement and may also require the repayment of the full amount of grant payments awarded under this Agreement, upon the occurrence of any of the following:
 - 1) the City of Medina determines that the certification as to delinquent taxes required by this Agreement is fraudulent, or
 - 2) **"The Company"** vacates the Facility and/or moves the Project out of the City of Medina or terminates its operations at the Facility altogether during a 9 (numeral) year period beginning on the effective date of this Agreement.

The City of Medina may, absent any legislative action, resolution or court ordered mandate to the contrary, collect any and all grant payments awarded under this Agreement, and **"The Company"** shall pay directly to the City of Medina or its authorized agent any and all grant payments awarded under this Agreement due on the date **"The Company"** moves the Project out of the City of Medina or terminates its operations at the Facility altogether during the 9 year period beginning on the effective date of this Agreement; or within ten (10) days from the date **"The Company"** is notified by the City of Medina that any tax certification is fraudulent.

G. **"The Company"** or successor entity shall promptly notify the City of Medina if any of the following events occur:

- (i) If control of **"The Company"** or substantially all of its assets located at the Project site is obtained by another entity or shareholders or
- (ii) If **"The Company"** merges with another entity or
- (iii) If **"The Company"** substantially restructures itself through an acquisition or divestiture or otherwise

and if any of these events affects the ability of **"The Company"** or its successor entity to perform substantially the obligations of **"The Company"** under this Agreement and to meet the employment and payroll projections anticipated herein. **"Control of 'The Company'"** for the purposes of this subsection means that persons and/or entities owning the majority of Company's outstanding voting stock at the date of this Agreement cease to own such or cease to have the unconditional right to elect a majority of **"The Company's"** board of directors.

H. Each provision for modification or termination hereunder shall not affect **"The Company's"** obligations or the City of Medina's rights under any other provision of this Agreement.

13. Fees. **"The Company"** shall pay an annual fee of \$ 500 (five hundred dollars) in each year that **"The Company"** has a grant agreement in effect upon notification that such payment is due. The proceeds will be used to defray costs of program administration and to help fund the program.

14. Any notices, statements, acknowledgements, consent approvals, certificates, or requests required to be given on behalf of either party shall be made in writing addressed as follows:

If to the City to: Dennis Hanwell, Mayor
Medina City Hall
132 N. Elmwood Avenue
Medina, Ohio 44256

With a copy to: Director of Law-- City of Medina
Gregory Huber
Medina City Hall
132 N. Elmwood Avenue
Medina, Ohio 44256

If to KRAFT WERKS ENGINEERING LLC to:

Kris Klingmann
935 Heritage Drive
Medina, Ohio 44256

or such other address as may be noticed.

15. Condition Precedent. **"The Company"** and Medina acknowledge that this Agreement must be approved by formal action of the legislative authority of the City of Medina as a condition for the Agreement to take effect.

IN WITNESS WHEREOF, the City of Medina, Ohio, by Dennis Hanwell, its Mayor, and pursuant to Ordinance No. 154-07 and **"The Company"**, by _____, have caused this instrument to be executed on the _____ day of _____, 2018.

WITNESSED BY:

CITY OF MEDINA

By: _____

Title: Mayor

WITNESSED BY:

KRAFT WERKS ENGINEERING LLC
(The Company)

By: _____

Title: _____

The legal form and correctness of the within instrument is hereby approved.

DIRECTOR OF LAW-- CITY OF MEDINA

By: _____

Date: _____

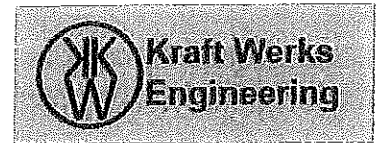

30 April 2021

City of Medina
Kimberly Marshall
Economic Development Director
132 N Elmwood
Medina, OH 44256

Kraft Werks Engineering LLC
935 Heritage Drive
Medina, OH 44256

Tel: +1 330 721 7374
Fax: +1 234 802 0460
Web: www.kraftwerkseng.com

Kraft Werks Engineering Job Creation Grant - Amendment Request

Dear Ms. Marshall,

The letter is to request that the Jobs Creation Grant (JCG) be amended because of a couple of miscalculations that were made at the time of the initial grant application submission.

As the only location of Kraft Werks Engineering is our facility here in Medina, it was assumed at the time the application was submitted that all employee wages would be attributable but unfortunately this is not the case. Kraft Werks Engineering currently has 6 full time employees that live out of state and work primarily from home or as traveling Field Service Technicians. Some of these employees lived locally in NE Ohio at the time they were hired in June 2018 and were part of our staff based out of our location in Medina but have since relocated and can no longer be counted as local wages or jobs created in the City of Medina.

At the time the grant was originally submitted, we had planned to organize the company as an S-Corp, but due to unforeseen circumstances, we were required to form the company as a partnership / LLC and the original application was amended accordingly prior to being approved. Because of this the salary for myself and our finance manager is not considered taxable wages attributable to the company in the city of Medina. In addition, at the beginning of 2020 we made one of our key employees a minority partner and his employment and compensation no longer counts toward the headcount or wages for the same reasons.

These differences account for 10 full time employees of Kraft Werks Engineering and more than \$1 million dollars in annual wages that are not attributable toward Kraft Werks Engineering meeting the annual payroll amounts or number of new hires in Medina for purposes of the Jobs Creation Grant as shown on the original grant application.

Based on the facts mentioned above, Kraft Werks Engineering is requesting the Jobs Creation Grant to be amended as follows:

Number of new Full-Time or Full-Time Equivalent employees added since the inception of the grant: **32**
Annual Payroll as a result of new employees added since the inception of the grant: **\$2,000,100.**



I would like to apologize again for the misunderstanding of how certain employees' wages would (or would not) be attributable to the Jobs Creation Grant and appreciate the City of Medina's consideration to this request to amend this grant accordingly.

Yours sincerely,

Kris Klingmann

Kris Klingmann,
President
Kraft Werks Engineering

**Job Creation Grant Estimate - Kraft Werks Engineering Rev Agmt
For Tax Years**

Projected New Payroll	\$ 2,000,100.00	\$ 2,000,100.00
Actual new Payroll	\$ 2,000,100.00	\$ 2,500,125.00
Percentage	100.00%	125.00%
Maximum basis	125.00%	125.00%
Base Payroll	\$ 2,000,100.00	\$ 2,500,125.00
W/H Tax Rate	1.25%	1.25%
Payroll W/H Tax*	\$ 25,001.25	\$ 31,251.56
Max Per Agreement	40.00%	40.00%
Reduction		0.00%
Grant	40.00%	40.00%
Amt of Grant	\$ 10,000.50	\$ 12,500.63

REQUEST FOR COUNCIL ACTION

OK
D. Hamerly
6-22-2021

NO. RCA 21-137-6/28

FROM: Patrick Patton 

COMMITTEE
REFERRAL: Finance

DATE: June 22, 2021

SUBJECT: Wheeling & Lake Erie Railroad Preliminary Engineering Agreement: West Smith Road, Phase 4

The City's upcoming West Smith Road project spans the Wheeling and Lake Erie Railway. Our project will not only install new pavement within the railroad right of way, but also install a water line beneath the crossing, storm sewer in the area, sidewalk, etc.

In order to secure a permit from the railroad to allow us to make these improvements, the railroad will need to review and approve our plans. They are requiring the City to enter into a preliminary engineering agreement with them to compensate them for their review time and for any engineering or design they may have to complete.

Thank you for your consideration.

ESTIMATED COST: \$12,000

SUGGESTED FUNDING:

Sufficient Funds in Account Number: 108-0610-54411

Transfer Needed From:
To:

New Appropriation:

Emergency Clause Requested: No

Reason:

COUNCIL USE ONLY:

COMMITTEE RECOMMENDATION:

Council Action Taken:

Ord./Res. Number:

Date:

Project: West Smith Road Reconstruction, PH 4, Medina, OH
ODOT PID: 112540

WLE AC&Y Subdivision Mile Post 140.12

Agreement No. _____

PRELIMINARY ENGINEERING AGREEMENT

This Engineering Agreement (“**Agreement**”) is made as of _____, 2021 by and between **Wheeling & Lake Erie Railway Company**, a Delaware corporation with its principal place of business in Ohio (“**RAILROAD**”), and the **City of Medina, Ohio**, (“**CITY**”)

EXPLANATORY STATEMENT

1. The CITY wishes to facilitate the development of plans for West Smith Road Reconstruction, Phase 4 (MED-CR 0004 – 15.47) over the RAILROAD’s AC&Y Subdivision tracks at Mile Post 140.12, in the City of Medina in Medina County, OH. (the “**Project**”).
2. The project work will include the following: 1) Installation of a new twelve (12) inch water line (bore and jack operation) beneath the RAILROAD’s tracks; 2) Removal and replacement of the existing concrete pavement within the railroad right-of-way adjacent to the existing precast concrete grade crossing panels (the existing panels will not be disturbed); 3) Installation of approximately 5 additional precast grade crossing panels, abutting the existing crossing; on the north side only; 4) Installation of new concrete sidewalk abutting both sides of the new grade crossing panels on the north side of West Smith Road. The CITY has requested that RAILROAD proceed with certain necessary engineering and/or design services for the Project to facilitate the parties’ consideration of the Project.
3. Subject to the approval of RAILROAD, which approval may not be unreasonably withheld, the Project is to be constructed, if at all, at no cost to RAILROAD, under a separate construction agreement to be executed by the parties at a future date.

NOW, THEREFORE, for and in consideration of the foregoing Explanatory Statement and other good and valuable consideration, the receipt and sufficiency of which are acknowledged by the parties, the parties agree as follows:

1. Scope of Work

1.1 Generally. The work to be done by RAILROAD under this Agreement may consist of: (1) the preparation or review and approval of engineering and design plans, specifications, drawings and other documents pertaining to the Project, (2) the preparation of cost estimates for RAILROAD’s work in connection with the Project, and (3) the review of construction cost estimates, site surveys, assessments, studies and related construction documents submitted to RAILROAD by the CITY for the Project (“**Engineering Work**”). Engineering Work may also include: (1) office reviews, (2) field reviews, (3) attendance at hearings and meetings, and (4) preparation of correspondence, reports, and other documentation in connection with the Project. Nothing contained in this Agreement shall oblige RAILROAD to perform work which, in RAILROAD’s opinion, is not relevant to RAILROAD’s participation in the Project.

1.2 Effect of RAILROAD Approval or Preparation of Documents. By its review, approval or preparation of plans, specifications, drawings or other documents pursuant to this Agreement

(collectively, the “Plans”), RAILROAD signifies only that the Plans and improvements constructed in accordance with the Plans satisfy RAILROAD’s requirements.

RAILROAD expressly disclaims all other representations and warranties in connection with the Plans, including, but not limited to, the integrity, suitability or fitness for the purposes of the CITY, or any other purpose of such Plans or improvements constructed in accordance with the Plans.

2. Reimbursement of RAILROAD Expenses.

2.1 Reimbursable Expenses. The CITY shall reimburse RAILROAD for all costs and expenses incurred by RAILROAD in connection with the Engineering Work, including, without limitation: (1) all out of pocket expenses, (2) travel and lodging expenses, (3) telephone, facsimile, and mailing expenses, (4) costs for equipment, tools, materials and supplies, (5) sums paid to consultants and subcontractors by RAILROAD and (6) RAILROAD labor, together with RAILROAD labor overhead percentages established by RAILROAD pursuant to applicable law, (collectively, “Reimbursable Expenses”).

2.2 Estimate. RAILROAD has estimated the total Reimbursable Expenses for the Project to be approximately \$12,000.00 (the “Estimate” as amended or revised). As per 23 CFR 646.216 (d) (vi), RAILROAD shall submit an itemized estimate for approval by the CITY prior to beginning work. In the event RAILROAD anticipates that actual Reimbursable Expenses may exceed such Estimate, it shall provide the CITY with the revised Estimate of total Reimbursable Expenses for the CITY’s approval and confirmation that sufficient funds have been appropriated to cover the total Reimbursable Expenses as reflected in the revised Estimate. RAILROAD may elect, by delivery of notice to the CITY, to immediately cease all further Engineering Work, unless and until CITY provides such approval and confirmation.

2.3 Federal Reimbursement. Any federal reimbursement to the CITY for railroad work performed on projects undertaken pursuant to the provisions of 23 CFR part 646, subpart B, shall be made in accordance with 23 CFR part 140, subpart I, as applicable.

2.4 Payment Terms

2.4.1 The CITY shall pay RAILROAD for Reimbursable Expenses in the amounts and on the dates set forth in the Payment Schedule attached to this Agreement as Exhibit A (the “Payment Schedule,” as revised from time to time pursuant to Section 2.2). RAILROAD agrees to submit invoices to the CITY for Reimbursable Expenses. The CITY shall remit payment to RAILROAD within thirty (30) days following delivery to the CITY of such proper invoice or, if later, the payment date (if any) set forth in the Payment Schedule.

2.4.2 Following completion of all Engineering Work, RAILROAD shall submit to the CITY a final invoice that reconciles the total Reimbursable Expenses incurred by RAILROAD against the total payments received from the CITY. The CITY shall pay to RAILROAD the amount by which actual Reimbursable Expenses exceed total payments, as shown by the final invoice, within thirty (30) days following delivery to CITY of the final invoice.

2.4.3 In the event that the CITY fails to pay RAILROAD any sums due RAILROAD under this Agreement: (i) the CITY shall pay RAILROAD interest as permitted by applicable law on the delinquent amount until paid in full; and (ii) RAILROAD may elect, by delivery of notice to CITY: (A) to immediately cease all further work on the Project, unless and until the CITY pays the entire delinquent sum, together with accrued interest; and/or (B) to terminate this Agreement.

2.4.4 All invoices from RAILROAD shall be delivered to the CITY in accordance with Section 6 of this Agreement. All payments by the CITY to RAILROAD shall be made by CITY issued warrant check and mailed to the following address or such other address as designated by RAILROAD's notice to CITY:

Wheeling & Lake Erie Railway Company
100 East First Street
Brewster, Ohio 44613

3. Appropriations. The CITY represents to RAILROAD that: (i) the CITY has obtained appropriations sufficient to reimburse RAILROAD for the Reimbursable Expenses encompassed by the initial Estimate; (ii) the CITY shall use its best efforts to obtain appropriations necessary to cover Reimbursable Expenses encompassed by subsequent Estimates approved by the CITY; and (iii) the CITY shall promptly notify RAILROAD in the event that the CITY is unable to obtain such additional appropriations. It is agreed and understood by all parties that the obligations described in this agreement are subject to Section 126.07 of the Ohio Revised Code.
4. Termination.
 - 4.1 By the CITY. The CITY may terminate this Agreement, for any reason, by delivery of notice to RAILROAD. Such termination shall become effective upon the expiration of fifteen (15) calendar days following delivery of notice to RAILROAD or such later date designated by the notice.
 - 4.2 By RAILROAD. RAILROAD may terminate this Agreement as provided pursuant to Section 2.4.3.
 - 4.3 Consequences of Termination. If the Agreement is terminated by either party pursuant to this Section or any other provision of this Agreement, the parties understand that it may be impractical for them to immediately stop the Engineering Work. Accordingly, they agree that, in such instance a party may continue to perform Engineering Work until it has reached a point where it may reasonably and safely suspend the Engineering Work. The CITY shall reimburse RAILROAD pursuant to this Agreement for the Engineering Work performed, plus all costs reasonably incurred by RAILROAD to discontinue the Engineering Work and all other costs of RAILROAD incurred as a result of the Project up to the time of full suspension of the Engineering Work. Termination of this Agreement or Engineering Work on the Project, for any reason, shall not diminish or reduce the CITY's obligation to pay RAILROAD for Reimbursable Expenses incurred in accordance with this Agreement. In the event of the termination of this Agreement or the Engineering Work for any reason, RAILROAD's only remaining obligation to the CITY shall be to refund to the CITY payments made to RAILROAD in excess of Reimbursable Expenses in accordance with Section 2.
5. Subcontracts. RAILROAD shall be permitted to engage consultants and subcontractors to perform all or any portion of the Engineering Work.
6. Notices. All notices, consents and approvals required or permitted by this Agreement shall be in writing and shall be deemed delivered upon personal delivery, upon the expiration of three (3) days following mailing by first class U.S. mail, or upon the next business day following mailing by a nationally recognized overnight carrier, to the parties at the addresses set forth below, or such other addresses as either party may designate by delivery of prior notice to the other party:

If to RAILROAD: Wheeling & Lake Erie Railway Company
100 East First Street
Brewster, OH. 44613
Attention: Jeffrey A. Davis, Jr.
Manager of Real ECITY

If to the CITY: City of Medina
132 N. Elmwood Avenue
Medina, OH 44256
Attn: Patrick Patton
City Engineer

7. Project Construction. Nothing contained in this Agreement shall be deemed to constitute RAILROAD's approval of or consent to the construction of the Project.
8. Entire Agreement. This Agreement embodies the entire understanding of the parties, may not be waived or modified except in a writing signed by authorized representatives of both parties, and supersedes all prior or contemporaneous written or oral understandings, agreements or negotiations regarding its subject matter. In the event of any inconsistency between this Agreement and the Exhibits, the more specific terms of the Exhibits shall be deemed controlling.
9. Waiver. If either party fails to enforce its respective rights under this Agreement, or fails to insist upon the performance of the other party's obligations hereunder, such failure shall not be construed as a permanent waiver of any rights or obligations in this Agreement.
10. Assignment. RAILROAD may assign this Agreement and all rights and obligations herein to a successor in interest, parent company, affiliate, or future affiliate. RAILROAD shall consult with the CITY prior to assignment. Upon assignment of this Agreement by RAILROAD and the assumption by RAILROAD's assignee of RAILROAD's obligations under this Agreement, RAILROAD shall have no further obligations under this Agreement. The CITY shall not assign its rights or obligations under this Agreement without RAILROAD's prior written consent, which consent may be withheld for any reason.
11. Termination by Operation of Law. If engineering efforts covered under said agreement are not complete by June 30, 2019, it is the expressed intention of the parties to renew said obligations for one successive biennium period; with the renewal period beginning July 1, 2019, and ending no later than June 30, 2021; until such time as engineering efforts covered under said agreement are complete. Said renewal is conditioned upon the CITY determining future appropriations will permit the CITY to renew said obligations.
12. Record Keeping Requirements. The RAILROAD shall keep all financial records in a manner consistent with generally accepted accounting procedures. Documentation to support each action shall be filed in a manner allowing it to be readily located. During the period covered by this contract and until the expiration of three years after final payment under this contract, the RAILROAD agrees to provide CITY, its duly authorized representatives or any person, agency, or instrumentality providing financial support to the work undertaken hereunder, with access to and the right to examine any books, documents, papers, and records of the RAILROAD involving transactions related to this contract.

13. Conflicts of Interest

- 13.1 No personnel of RAILROAD who exercises any functions or responsibilities in connection with the review or approval of the understanding or carrying out of any such work, shall, prior to the completion of said work, voluntarily acquire any personal interest, direct or indirect, which is incompatible or in conflict with the discharge and fulfillment of his or her functions and responsibilities with respect to the carrying out of said work.
- 13.2 Any such person who acquires an incompatible or conflicting personal interest, on or after the effective date of this contract, or who involuntarily acquires any such incompatible or conflicting personal interest, shall immediately disclose his or her interest to CITY in writing. Thereafter, he or she shall not participate in any action affecting the work under this contract, unless CITY shall determine that, in the light of the personal interest disclosed, his or her participation in any such action would not be contrary to the public interest.

14. Equal Employment Opportunity

- 14.1 In carrying out this contract, the RAILROAD shall not discriminate against any employee or applicant for employment because of race, religion, color, sex, national origin, disability, sexual orientation, gender identity, or age. The RAILROAD will ensure that applicants who are hired to perform the Engineering Work and that employees performing the Engineering Work are treated during employment without regard to their race, religion, color, sex, national origin, disability, sexual orientation, gender identity, or age. Such action shall include, but not be limited to, the following: Employment, Upgrading, Demotion, or Transfer; Recruitment or Recruitment Advertising; Layoff or Termination; Rates of Pay or other forms of Compensation; and Selection for Training including Apprenticeship.
- 14.2 The RAILROAD agrees that while it is performing the Engineering Work it will post on the internet notices setting forth the provisions of this nondiscrimination clause. In all solicitations or advertisements for employees placed by or on behalf of the RAILROAD for the Engineering Work, the RAILROAD will CITY that all qualified applicants will receive consideration for employment without regard to race, religion, color, sex, national origin, disability, or age. The RAILROAD shall incorporate the foregoing requirements of this paragraph in all of its contracts for any of the work prescribed herein (other than subcontracts for standard commercial supplies or raw materials) and will require all of its subcontractors for any part of such work to incorporate such requirements in all subcontracts for such work.
- 14.3 RAILROAD agrees to fully comply with Title VI of the Civil Rights Act of 1964, 42 USC Sec. 2000. RAILROAD shall not discriminate on the basis of race, color, or national origin in its programs or activities. The Director of Transportation may monitor the RAILROAD's compliance with Title VI.
15. Antitrust. CITY and the RAILROAD recognize that in actual economic practice, overcharges resulting from antitrust violations are usually borne by CITY. As consideration for the award of the contract, and intending to be legally bound, the RAILROAD assigns to CITY all right, title and interest, to all claims and causes of action the RAILROAD now has or may acquire under CITY or federal antitrust laws PROVIDED that the claims or causes of action relate to the goods or services that are acquired and used for purposes of the Engineering Work and are Reimbursable Expenses, and EXCEPT as to any claims or causes of action which result from antitrust violations that occur after the price is established under the Contract and that are not passed on to CITY. Additionally,

RAILROAD warrants that any overcharges resulting from antitrust violations by RAILROAD's first tier suppliers and subcontractors shall not be knowingly passed on to CITY.

16. Compliance with Law. The RAILROAD agrees to comply with all applicable federal, CITY, and local laws in the conduct of the work hereunder. RAILROAD accepts full responsibility for payment of all taxes including without limitation, unemployment compensation insurance premiums, all income tax deductions, social security deductions, and any and all other taxes or payroll deductions required for all employees engaged by RAILROAD in the performance of the work authorized by this contract. CITY is exempt from federal excise taxes and all CITY and local taxes, unless otherwise provided herein. CITY does not agree to pay any taxes on commodities, goods, or services acquired from any RAILROAD.
17. Certification of Funds. It is expressly understood by the parties that none of the rights, duties, and obligations described in this contract shall be binding on either party until all statutory provisions under the Ohio Revised Code, including but not limited to Section 126.07, have been complied with and until such time as all necessary funds are made available and forthcoming from the appropriate CITY agencies, and, when required, such expenditure of funds is approved by the General Assembly and by the Controlling Board of the CITY of Ohio or, in the event that federal funds are used, until such time that CITY gives the RAILROAD written notice that such funds have been made available to CITY, by CITY's funding source.
18. Change or Modifications. Either party may, at any time during the term of this contract, request amendments or modifications. Requests for amendments or modifications shall be in writing and shall specify the requested changes and the justifications of such changes. Should the parties consent to modification of the contract, then an amendment shall be drawn, approved, and executed in the same manner as the original contract.
19. Applicable Law. This Agreement shall be governed by the laws of the CITY of Ohio and any applicable federal law, specifically 23 CFR part 646, subpart B.
20. Governing Law/Severability.
 - 20.1 This Contract and any claims arising out of this Contract shall be governed by the laws of the CITY of Ohio. Any provision of this Contract prohibited by the law of Ohio shall be deemed void and of no effect.
 - 20.2 If any provision of the Contract or the application of any such provision shall be held by a court of competent jurisdiction to be contrary to law, the remaining provisions of the Contract shall remain in full force and effect.
21. Drug-Free Workplace. RAILROAD agrees to comply with all applicable CITY and federal laws regarding drug-free workplace. RAILROAD shall make a good faith effort to ensure that all RAILROAD employees, while performing the Engineering Work on CITY property, will not purchase, transfer, use or possess illegal drugs or alcohol or abuse prescription drugs in any way.
22. Ohio Ethics Law Requirements. In accordance with Executive Order 2007-01S, RAILROAD, by signing this document, certifies: (1) it has reviewed and understands Executive Order 2007-01S, (2) has reviewed and understands the Ohio ethics and conflict of interest laws, and (3) will take no action inconsistent with those laws and this order. RAILROAD understands that failure to comply with Executive Order 2007-01S is, in itself, grounds for termination of this contract and may result in the loss of other contract with the CITY of Ohio.

23. Ohio Elections Law. RAILROAD certifies that all applicable parties listed in Division (I)(3) or (J)(3) of R.C. 3517.13 are in compliance with Divisions (I)(1) and (J)(1) of R.C. 3517.13.
24. Force Majeure. Except as otherwise provided herein, neither the RAILROAD nor CITY shall be liable to the other for any delay or failure of performance of any provisions contained herein, nor shall any such delay or failure or performance constitute default hereunder, to the extent that such delay or failure is caused by force majeure. The term force majeure, as used herein shall mean without limitation: acts of God, such as epidemics; lightning; earthquakes; fire, storms; hurricanes; tornadoes; floods; washouts; droughts, or other severe weather disturbances; explosions; arrests; restraint of government and people; and other such events or any other cause which could not be reasonably foreseen in the exercise of ordinary care, and which is beyond the reasonable control of the party affected and said party is unable to prevent.
25. CITY Audit Findings. RAILROAD affirmatively represents to CITY that it is not subject to a Finding for Recovery under R.C. 9.24, or that it has taken the appropriate remedial steps required under R.C. 9.24 or otherwise qualifies under that section. RAILROAD agrees that if this representation is deemed to be false, the contract shall be void *ab initio* as between the parties to this contract, and any funds paid by CITY hereunder shall be immediately repaid to CITY, or an action for recovery may be immediately commenced by CITY for recovery of said funds.
26. Debarment. RAILROAD represents that it is not debarred from consideration for contract awards by the Director of the Department of Administrative Services, pursuant to either R.C. 5513.06 or R.C. 125.25. If this representation is found to be false, this Agreement is void *ab initio* and RAILROAD shall immediately repay to CITY any funds paid under this Agreement.
27. Signatures. Any person executing this Contract in a representative capacity hereby warrants that he/she has been duly authorized by his/her principal to execute this Contract on such principal's behalf.

IN WITNESS WHEREOF, the parties have caused this Agreement to be executed in duplicate, each by its duly authorized officers, as of the date of this Agreement.

City of Medina, OH:

By: _____
 Dennis Hanwell
 Mayor

Wheeling & Lake Erie Railway Company

By: _____
 Print Name: _____
 Title: _____

EXHIBIT A

PAYMENT SCHEDULE

Progress Payments

Notwithstanding anything to the contrary set forth in this Agreement, the CITY shall pay RAILROAD in arrears for its Reimbursable Expenses, rather than in advance, with only such exceptions, such as purchasing materials and equipment, as the parties mutually agree. Accordingly, the CITY shall remit full payment to RAILROAD, with no retainage, for its Reimbursable Expenses within thirty (30) days following delivery to the CITY of an invoice.

REQUEST FOR COUNCIL ACTION

FROM: Patrick Patton

DATE: June 22, 2021

SUBJECT: Job #1085: Memorandum of Understanding with Medina County relative to water service on SR 18

NO. RCA 21-138-6/28

COMMITTEE REFERRAL: Finance

*OK
6-22-21
Hansen*

This request asks Council to enter into a Memorandum of Understanding (MOU) with Medina County relative to the transfer of certain water services on State Route 18 from the City to the County.

The City desires to abandon the large water main running from the water plant, through Lake Medina, then along SR 18 to Footè Road. Because the City now receives its drinking water from Avon Lake through our Litchfield pump station west of the City, the large mains extending from the water plant are not necessary anymore and present a maintenance and repair liability.

In order to abandon these lines, water service will have to transfer from City supplied to Medina County supplied at the following locations:

- Woodlake Subdivision, Phase I & II
- The Woods At Lake Medina Condominiums, Phases I Through IV,
- Serenity Hollow Cluster Homes Subdivision, Phases I Through VIII,
- The Retreat At Lake Medina Cluster Homes Subdivision, Phase I
- 3866 Medina Road

In total that represents a total of 86 residential properties and 2 commercial properties. As noted in the MOU, in addition to changing out the individual water meters, in order to make this transfer between water systems, a total of four water service locations must be changed from City to County. The cost of this work is estimated at \$91,000; this MOU requires the County and the City to each pay an equal share (\$45,500) of the total costs.

Thank you for your consideration

ESTIMATED COST: \$91,000.

SUGGESTED FUNDING: Street Capital and Water Capital Improvements

Sufficient Funds in Account Number: 108 0610 54411 ^{\$91,000} (~~\$45,500~~)
Medina County (~~\$45,500~~)

Transfer Needed from: to:

New Appropriation Account Number:

Emergency Clause Requested: No
Reason:

COUNCIL USE ONLY:

COMMITTEE RECOMMENDATION:

Council Action Taken:

Ord./Res. Number:

Date:

MEMORANDUM OF UNDERSTANDING

TRANSFER of WATER SERVICE PROVIDER for PARCELS LOCATED in the TOWNSHIP OF MEDINA
within the WOODLAKE SUBDIVISION, PHASE I & II
THE WOODS AT LAKE MEDINA CONDOMINIUMS, PHASES I THROUGH IV,
SERENITY HOLLOW CLUSTER HOMES SUBDIVISION, PHASES I THROUGH VIII,
THE RETREAT AT LAKE MEDINA CLUSTER HOMES SUBDIVISION, PHASE I,
and 3866 MEDINA ROAD

Terms to be contained in a Memorandum of Understanding ("MOU") between the MEDINA COUNTY COMMISSIONERS (County), and the CITY OF MEDINA (CITY).

Section I: Project Description

The CITY is currently the water service provider for 86 residential properties and 2 commercial properties within the subdivisions noted above and as shown in Exhibit "A" that are within Medina Township outside the CITY limits. The CITY'S 16", 20" and 24" water mains that services these areas along Medina Road (SR 18) and along Lake Medina are aging and will need to be repaired / replaced in the near future.

The Medina County Sanitary Engineers (MCSE) currently has existing water mains that run parallel to the CITY'S water main(s) through the Lake Medina parcel and along Medina Road that can provide water service to these properties.

The Ohio Department of Transportation (ODOT) will begin completing a widening project, MED -18-12.99, along Medina Road in 2021 with construction to be complete by 2024. This work will impact the CITY'S existing water mains along Medina Road and would necessitate the replacement/relocation a portion of these lines with costs to be borne by the City.

The CITY requests that the COUNTY become the water service provider for the 86 residential properties and the 2 commercial properties by transferring water service at four locations as indicated on Exhibit "B". With the transfer of service the COUNTY will assume ownership and maintenance responsibilities of all existing CITY water mains that service these properties.

Construction and transfer of water service is tentatively scheduled to begin in the summer of 2021.

Section II – Consent Statement

Being in the public interest, the CITY gives consent to the COUNTY to complete the transfer of the water service(s) from the CITY'S water supply system to the COUNTY'S water supply system.

Section III - Cooperation Statement

The CITY and the COUNTY shall cooperate as follows:

1. The CITY and COUNTY shall each bear fifty percent (50%) of the total costs for engineering, materials, labor, equipment, construction, inspection, surveying and project administration for this project.
2. The COUNTY shall draft a scope of work for the water transfer locations "1", "2", and "3" as shown on the Exhibit "B" and submit to the CITY for review. The COUNTY and CITY shall agree on the scope for each location prior to soliciting for proposals to complete the work.
3. The CITY shall solicit a minimum of three (3) proposals from contractors based on the agreed upon scope of work for the three (3) water transfer locations. The CITY shall provide the proposals to the COUNTY for review and the CITY and COUNTY shall agree upon the proposal to be selected.
4. The water transfer for location #4, as shown on Exhibit "B", shall be completed through the ODOT MED-18-12.99 project based on the ODOT unit price items. The CITY shall reimburse the COUNTY for fifty (50) percent of the total costs for this water service installation based on the ODOT contract unit prices.
5. The CITY shall enter into a contract with the selected contractor for the completion of the water service transfer work. All payments per the contact shall be made by the CITY.
6. Upon completion of the water service transfers, the County shall furnish and install new water meters to each of the water meter service locations. The City and the County shall each bear 50% of the costs for the purchase of the new water meters.
7. The preliminary cost estimate to fully complete the water service transfer of all properties from the CITY's water supply system to the COUNTY'S is as follows:
 - Water service transfer location #1 (3866 Medina Road): \$4,500.
 - Water service transfer location #2 (Burgundy Bay-Lake Medina): \$35,000.
 - Water service transfer location #3 (Retreat, Ph. I): \$16,000.
 - Water service transfer location #4 (Burgundy Bay-Medina Rd): \$24,00.
 - Water meter change out equipment costs: \$9,000.
 - Survey / Easements costs: \$2,500.

 - Total preliminary cost = \$91,000
8. The COUNTY agrees to provide all costs and invoices for all equipment and meters associated with the project. The actual final total cost for the project shall be calculated by the CITY upon completion of all project components as listed above and provided to the COUNTY for review. The COUNTY and CITY shall agree upon the final total project cost. The CITY shall provide the COUNTY with an invoice for their share (50%) of the total cost for the project.
9. The COUNTY shall submit payment for their total share (50%) due to the CITY within sixty (60) days after receiving the invoice from the CITY.

Section IV – Ownership and Maintenance

The COUNTY shall take ownership and maintenance responsibilities for all current CITY owned water mains and appurtenances within the project limits as shown on the attached Exhibit "B" that shall be remain in service and be used for water supply by the COUNTY.

MEDINA COUNTY COMMISSIONERS

CITY OF MEDINA, OHIO

By (signature): _____

By (signature): _____

Printed Name: _____

Printed Name: _____

Title: _____

Title: _____

Date: _____

Date: _____

REQUEST FOR COUNCIL ACTION

*OK
as Howard
6-22-2021*

NO. RCA 21-139.6/28

FROM: Patrick Patton

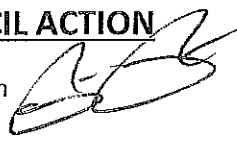

COMMITTEE REFERRAL: Finance

DATE: June 22, 2021

SUBJECT: Easements for Job #1074: Lindenwood Headwall Replacement

In order to complete project Job #1074: Lindenwood Headwall Replacement, the City must acquire a total of two (2) easements from property owners. Attached are both of the easements needed for this project; see below for a summary:

	Property	Acquisition	Value
1	811 Lindenwood Lane PPN 028-19B-11-027; MCL #2796	One (1) storm sewer and drainage easement	\$2,878.07
2	850 Shorewood Drive PPN 028-19B-11-028; MCL #4496	One (1) storm sewer and drainage easement	\$2,210.40
TOTAL			\$5,088.47

This requests asks Council to accept the easements submitted herein. Thank you for your cooperation.

ESTIMATED COST: \$5,088.47

SUGGESTED FUNDING: 108-0610-54411

Sufficient Funds in Account Number:

Transfer Needed from: To:

New Appropriation Account Number:

Emergency Clause Requested: NO

Reason:

COUNCIL USE ONLY:

COMMITTEE RECOMMENDATION:

Council Action Taken:

Ord./Res. Number:
Date:

1.
p lot 5

Storm Sewer and Drainage Easement

KNOW ALL MEN BY THESE PRESENTS:

That in consideration of (TWO THOUSAND EIGHT HUNDRED SEVENTY EIGHT and 07/100) Dollars (\$2,878.07) and other good and valuable consideration recited herein given to RAYMOND A. TOMAZIC and SANDRA S. TOMAZIC (Husband and Wife) hereinafter "Grantor(s)" by the CITY OF MEDINA, Ohio, hereinafter "Grantee", the receipt of which is hereby acknowledged, the Grantor does hereby grant, bargain, sell, transfer and convey unto the Grantee, its successors and assigns, a drainage and storm sewer easement for the purpose of erecting, constructing, installing and thereafter using, operating, inspecting, maintaining, repairing, replacing and removing STORM SEWER AND APPURTENANCES under, across, and through certain land of the Grantor(s) situated in the City of Medina, County of Medina and State of Ohio and more particularly described as follows:

Situated in the City of Medina, County of Medina and State of Ohio, known as being part of Medina City Lot 2796, as recorded in Plat Volume 13, Page 4 of Medina County Recorder's Records, also being a part of land conveyed to Raymond A. Tomazic and Sandra S. Tomazic by deed recorded on August 12, 1999 in Document Number 1999OR028230 of Medina County Recorder's Record further bounded and described as follows:

Commencing at a 5/8-inch iron pin found without cap at the Southwest corner of said Medina City Lot No. 2796, the same being a point in the Northern line of Lindenwood Lane having a 60 foot wide right of way and the TRUE PLACE OF BEGINNING of the drainage easement herein described;

Thence along the Northern line of said Medina City Lot No. 2796, bearing North 45°12'31" East, a distance of 80.00 feet to a point thereon;

Thence, bearing South 44°47'29" East, a distance of 12.02 feet to an angle point;

Thence, bearing South 10°31'57" West, a distance of 49.22 feet to a point in the Northern line of said Lindenwood Lane;

Thence along the Northern line of said Lindenwood Lane along the arc of a curve to the left with a radius of 1181.4 feet, a tangent length of 28.13 feet, a delta of 02°43'42", the chord which bears North 89°25'52" West, for a distance of 56.25 feet, along said arc for a distance of 56.26 feet to the Southwest corner of said Medina City Lot No. 2796 and the TRUE PLACE OF BEGINNING, containing 0.0421 acres (1,832 square feet) of land, more or less but subject to all legal highways and all covenants of record.

Bearings are based on an assumed meridian and are used herein to indicate angles only.

This legal description was prepared based on a survey under the supervision of Andrew G. Planet, P.S. No. S-7802 by Rolling & Hocevar, Inc. in October 2020.

together with the right of reasonable ingress and egress over the immediately adjacent lands of the Grantor(s) for the purpose and use of said easement. The Grantee covenants and agrees that it will not use said easement for public right-of-way purposes.

#1
p. 2 of 5

As additional consideration for this easement and right-of-way, the Grantee covenants and agrees as follows:

1. Grantee shall repair any and all damage arising from the installation or subsequent repair, maintenance or reconstruction of a STORM SEWER AND APPURTENANCES.
2. Grantee shall replace any driveway, lawn, shrubbery, or other improvement which may be damaged as a result of construction.
3. Within a reasonable time after completion of construction, and in no event later than forty-five (45) days, Grantee will return the ground to its original condition.
4. Grantee will secure and protect all permanent structures within the construction zone.
5. Grantee will pay for all costs of surveying, recording of documents, filing and transfer fees, escrow costs and title expenses, if any.

Grantor(s) covenant and agrees as follows:

1. Grantor will not install, erect or maintain any structure, fixture or device upon the easement which could in any way interfere with Grantee's use of the easement and right-of-way; however, Grantor retains the right to use the surface of the easement area provided said use does not interfere with the uses granted to Grantee.
2. Authorize the City of Medina, its Engineer, and all other officials, assistants, employees, agents and contractors thereof to enter upon the property designated as 811 Lindenwood Lane; Permanent Parcel No. 028-19B-11-027, part of Medina City Lot 2796 with the necessary equipment to remove any obstructions as necessary to allow for the proposed storm sewer headwall installation including tree stumps, brush, vegetation, and landscaping; to install the proposed headwall, appurtenances and rock channel protection; to complete grading as necessary; to restore the affected areas with topsoil, seed, fertilizer, and mulch in accordance with the plans and/or specifications as prepared by the City of Medina or its agents during the period of time commencing with the breaking of ground for the above described proposed work and terminating when the work has been completed and/or accepted by the City; and
3. Release the City of Medina, its Engineer, and all other officials, assistants, employees, agents and contractors thereof, from claims of damage, of compensation by reason of the above described work as called for by the said plans and/or specifications provided that the property designated as 811 Lindenwood Lane; Permanent Parcel No. 028-19B-11-027, part of Medina City Lot 2796 is restored to the condition before construction or as close as reasonably possible in conformance with the plans and/or specifications and/or proposed work described above.

All the terms and conditions of this Easement and Right-of-way shall be binding upon and inure to the benefit of the Grantor(s), the Grantee, their heirs, executors, administrator, successors and assigns.

The grant of this Easement and Right-of-way shall constitute a covenant running with the land for the benefit of the Grantee, its successors and assigns.

#1
p. 3 of 5

IN WITNESS WHEREOF, the undersigned has executed this instrument this 18 day of DECEMBER, 2020.

Grantor:

Raymond A. Tomazic

Signature: [Handwritten Signature]
Print Name: RAYMOND TOMAZIC

State of Ohio)
County of Medina) SS:

Before me, a Notary Public, in and for said County and State, personally appeared the Grantor, Raymond A. Tomazic, who acknowledged that he/she/they did sign the foregoing instrument and that the same is his/her/their free act and deed.

In testimony whereof, I have set my hand and official seal at Medina, Ohio, this 18th day of December, 2020.



Notary Signature: [Handwritten Signature]
Notary Public, State of Ohio: DERRICK J. COPE
My Commission Expires: October 7, 2025
COMMISSION: 2015-RE-54277

IN WITNESS WHEREOF, the undersigned has executed this instrument this 18 day of DECEMBER, 2020.

Grantor:

Sandra S. Tomazic

Signature: [Handwritten Signature]
Print Name: SANDRA S. TOMAZIC

State of Ohio)
County of Medina) SS:

Before me, a Notary Public, in and for said County and State, personally appeared the Grantor, Sandra S. Tomazic, who acknowledged that he/she/they did sign the foregoing instrument and that the same is his/her/their free act and deed.

In testimony whereof, I have set my hand and official seal at Medina, Ohio, this 18th day of December, 2020.



Notary Signature: [Handwritten Signature]
Notary Public, State of Ohio: DERRICK J. COPE
My Commission Expires: October 7, 2025
COMMISSION: 2015-RE-54277

This instrument was prepared by:
Gregory Huber, Law Director, City of Medina, Ohio
132 N. Elmwood Avenue
Medina, OH 44256

SKETCH OF EASEMENT CREATING A DRAINAGE EASEMENT

SITUATED IN THE CITY OF MEDINA, COUNTY OF
MEDINA AND STATE OF OHIO, ALSO KNOWN AS BEING
PART OF MEDINA CITY LOT 2796.

C-1
Arc: 56.26'
Radius: 1181.40'
Delta: 002° 43' 42"
Tangent: 28.13'
Chord: 56.25'
Brg: N89° 25' 52"W

L-1
Course: N45° 12' 31"E
Length: 80.00'

L-2
Course: S44° 47' 29"E
Length: 12.02'

L-3
Course: S10° 31' 57"W
Length: 49.22'

OCTOBER 2020

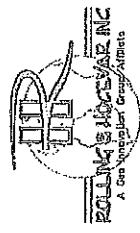

CIVIL ENGINEERING & SURVEYING
257 SOUTH COURT STREET
SUITE 6
MEDINA, OHIO 44256
PHONE: (330)723-1828
FAX: (330)723-6637

PROJECT No. 31-979

LEGEND
- PROPOSED DRAINAGE EASEMENT

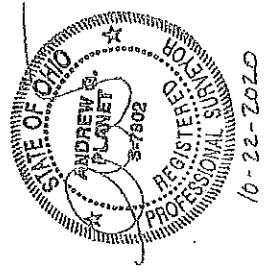

PPN 028-19B-11-027
MCL 2796
FOREST MEADOWS SUBD. NO. 6
PLAT VOL. 13, PAGE 4
RAYMOND A. & SANDRA S. TOMAZIC
DOC. NO. 1999OR028230
08-12-1999

MCL 4497
PPN 028-19B-11-028
MCL 4496
PLAT VOL. 19, PAGE 247
ROBERT A. BLOMQUIST &
KATHERINE J. BAILLIS
DOC. NO. 2003OR045480
08-26-2003

MCL 2709

MCL 2710

DRAINAGE EASEMENT - NO. 1
0.0421 ACRES (1.832 S.F.)

LINDENWOOD LANE 60' R/W

I.P.O.B.

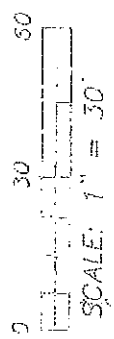

NOTE: BEARINGS ARE BASED ON
AN ASSUMED MERIDIAN AND ARE
USED TO DENOTE ANGLES ONLY.

1
P. 10/25

#1
p. 5 of 5

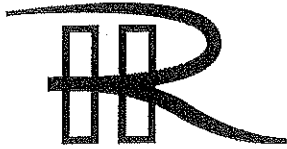

ROLLING & HOCEVAR
A Geo Innovation Group Affiliate

Engineering and Surveying
257 S. Court St. • Suite 6
Medina, Ohio 44256
Phone: 330-723-1828 • 800-723-1870
Fax: 330-723-6637
E-mail: info@rh-inc.com

Legal Description for Drainage Easement No. 1
Project No. 31,979
October 22, 2020

Situated in the City of Medina, County of Medina and State of Ohio, known as being part of Medina City Lot No. 2796, as recorded in Plat Volume 13, Page 4 of Medina County Recorder's Records, also being a part of land conveyed to Raymond A. Tomazic and Sandra S. Tomazic by deed recorded on August 12, 1999 in Document Number 1999OR028230 of Medina County Recorder's Records further bounded and described as follows:

Commencing at a 5/8-inch iron pin found without cap at the Southwest corner of said Medina City Lot No. 2796, the same being a point in the Northern line of Lindenwood Lane having a 60-foot wide right of way and the **TRUE PLACE OF BEGINNING** of the drainage easement herein described;

Thence along the Northern line of said Medina City Lot No. 2796, bearing North 45°12'31" East, a distance of 80.00 feet to a point thereon;

Thence, bearing South 44°47'29" East, a distance of 12.02 feet to an angle point;

Thence, bearing South 10°31'57" West, a distance of 49.22 feet to a point in the Northern line of said Lindenwood Lane;

Thence along the Northern line of said Lindenwood Lane along the arc of a curve to the left with a radius of 1181.4 feet, a tangent length of 28.13 feet, a delta of 02° 43' 42", the chord which bears North 89°25'52" West, for a distance of 56.25 feet, along said arc for a distance of 56.26 feet to the Southwest corner of said Medina City Lot No. 2796 and the **TRUE PLACE OF BEGINNING**, containing 0.0421 acres (1,832 square feet) of land, more or less but subject to all legal highways and all covenants of record.

Bearings are based on an assumed meridian and are used herein to indicate angles only.

This legal description was prepared based on a survey under the supervision of Andrew G. Planet, P.S. No. S-7802 by Rolling & Hocevar, Inc. in October 2020.

2.
p. 1 of 5

Storm Sewer and Drainage Easement

KNOW ALL MEN BY THESE PRESENTS:

That in consideration of TWO THOUSAND TWO HUNDRED TEN and 40/100 Dollars (\$2,210.40) and other good and valuable consideration recited herein given to ROBERT A. BLOMQUIST and KATHERINE J. BAILLIS hereinafter "Grantor(s)" by the CITY OF MEDINA, Ohio, hereinafter "Grantee", the receipt of which is hereby acknowledged, the Grantor does hereby grant, bargain, sell, transfer and convey unto the Grantee, its successors and assigns, a drainage and storm sewer easement for the purpose of erecting, constructing, installing and thereafter using, operating, inspecting, maintaining, repairing, replacing and removing STORM SEWER AND APPURTENANCES under, across, and through certain land of the Grantor(s) situated in the City of Medina, County of Medina and State of Ohio and more particularly described as follows:

Situated in the City of Medina, County of Medina and State of Ohio, known as being part of Medina City Lot No. 4496, as recorded in Plat Volume 19, Page 247 of Medina County Recorder's Records, also being a part of land conveyed to Robert A. Blomquist and Katherine J. Baillis by deed recorded on August 26, 2003 in Document No. 2003OR045480 of Medina County Recorder's further bounded and described as follows:

Commencing at a 5/8-inch iron pin found without cap at the Southwest corner of said Medina City No. 4496, the same being a point in the Northern line of Lindenwood Lane having a 60-foot wide right of way and the TRUE PLACE OF BEGINNING of the drainage easement herein described;

Thence along the Wester line of said Medina City Lot No. 4496, bearing North 00°47'43" West, a distance of 27.80 feet to a point thereon;

Thence, bearing North 45°12'31" East, a distance of 60.69 feet to an angle point;

Thence, bearing South 44°47'29" East, a distance of 20.00 feet to a point in the Southern line of said Medina City Lot No. 4496;

Thence along the Southern line of said Medina City Lot No. 4496, bearing South 45°12'31" West, a distance of 80.00 feet to the Southwest corner of said Medina City Lot No. 4496 and the TRUE PLACE OF BEGINNING, containing 0.0323 acres (1,407 square feet) of land, more or less but subject to all legal highways and all covenants of record.

Bearings are based on an assumed meridian and are used herein to indicate angles only.

This legal description was prepared based on a survey under the supervision of Andrew G. Planet, P.S. No. S-7802 by Rolling & Hocevar, Inc. in October 2020.

together with the right of reasonable ingress and egress over the immediately adjacent lands of the Grantor(s) for the purpose and use of said easement. The Grantee covenants and agrees that it will not use said easement for public right-of-way purposes.

#2
p. 2 of 5

As additional consideration for this easement and right-of-way, the Grantee covenants and agrees as follows:

1. Grantee shall repair any and all damage arising from the installation or subsequent repair, maintenance or reconstruction of a STORM SEWER AND APPURTENANCES.
2. Grantee shall replace any driveway, lawn, shrubbery, or other improvement which may be damaged as a result of construction.
3. Within a reasonable time after completion of construction, and in no event later than forty-five (45) days, Grantee will return the ground to its original condition.
4. Grantee will secure and protect all permanent structures within the construction zone.
5. Grantee will pay for all costs of surveying, recording of documents, filing and transfer fees, escrow costs and title expenses, if any.

Grantor(s) covenant and agrees as follows:

1. Grantor will not install, erect or maintain any structure, fixture or device upon the easement which could in any way interfere with Grantee's use of the easement and right-of-way; however, Grantor retains the right to use the surface of the easement area provided said use does not interfere with the uses granted to Grantee.
2. Authorize the City of Medina, its Engineer, and all other officials, assistants, employees, agents and contractors thereof to enter upon the property designated as 850 Shorewood Drive; Permanent Parcel No. 028-19B-11-028, part of Medina City Lot 4496 with the necessary equipment to remove any obstructions as necessary to allow for the proposed storm sewer headwall installation including tree stumps, brush, vegetation, and landscaping; to install the proposed headwall, appurtenances and rock channel protection; to complete grading as necessary; to restore the affected areas with topsoil, seed, fertilizer, and mulch in accordance with the plans and/or specifications as prepared by the City of Medina or its agents during the period of time commencing with the breaking of ground for the above described proposed work and terminating when the work has been completed and/or accepted by the City; and
3. Release the City of Medina, its Engineer, and all other officials, assistants, employees, agents and contractors thereof, from claims of damage, of compensation by reason of the above described work as called for by the said plans and/or specifications provided that the property designated as 850 Shorewood Drive; Permanent Parcel No. 028-19B-11-028, part of Medina City Lot 4496 is restored to the condition before construction or as close as reasonably possible in conformance with the plans and/or specifications and/or proposed work described above.

All the terms and conditions of this Easement and Right-of-way shall be binding upon and inure to the benefit of the Grantor(s), the Grantee, their heirs, executors, administrator, successors and assigns.

The grant of this Easement and Right-of-way shall constitute a covenant running with the land for the benefit of the Grantee, its successors and assigns.

IN WITNESS WHEREOF, the undersigned has executed this instrument this 18th day of JUNE, 2021.

Grantor:
Robert A. Blomquist

Signature: [Handwritten Signature]
Print Name: Robert Blomquist

State of Ohio)
County of Medina) SS:

Before me, a Notary Public, in and for said County and State, personally appeared the Grantor, **Robert A. Blomquist**, who acknowledged that he/she/they did sign the foregoing instrument and that the same is his/her/their free act and deed.

In testimony whereof, I have set my hand and official seal at Medina, Ohio, this 18th day of JUNE, 2021.

Notary Signature: [Handwritten Signature]
Print Name: SERAFINO S. PICCOLI
My Commission Expires: OCTOBER 26, 2024
Notary Seal:

IN WITNESS WHEREOF, the undersigned has executed this instrument this 18th day of JUNE, 2021.

Grantor:
Katherine J. Baillis

Signature: [Handwritten Signature]
Print Name: Katherine Blomquist

State of Ohio)
County of Medina) SS:

Before me, a Notary Public, in and for said County and State, personally appeared the Grantor, **Katherine J. Baillis**, who acknowledged that he/she/they did sign the foregoing instrument and that the same is his/her/their free act and deed.

In testimony whereof, I have set my hand and official seal at Medina, Ohio, this 18th day of JUNE, 2021.

Notary Signature: [Handwritten Signature]
Print Name: SERAFINO S. PICCOLI
My Commission Expires: OCTOBER 26, 2024
Notary Seal:

This instrument was prepared by:
Gregory Huber, Law Director, City of Medina, Ohio
132 N. Elmwood Avenue
Medina, OHed 44256

#2
P. 4025

**SKETCH OF EASEMENT
CREATING A DRAINAGE EASEMENT**

SITUATED IN THE CITY OF MEDINA, COUNTY OF
MEDINA AND STATE OF OHIO, ALSO KNOWN AS BEING
PART OF MEDINA CITY LOT 4496.

LEGEND
- PROPOSED DRAINAGE EASEMENT

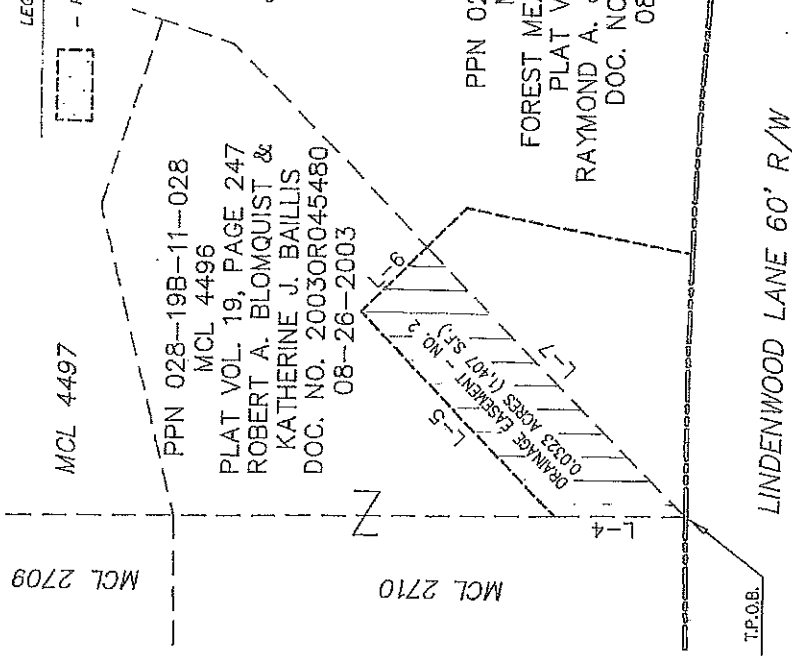
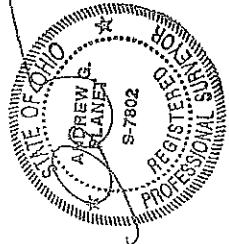

- L-4 Course: N00° 47' 43"W Length: 27.80'
- L-5 Course: N45° 12' 31"E Length: 60.69'
- L-6 Course: S44° 47' 29"E Length: 20.00'
- L-7 Course: S45° 12' 31"W Length: 80.00'

OCTOBER 2020

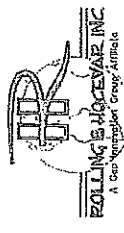

POLLING & McDEVARE INC.
A Geospatial Group Affiliata
CIVIL ENGINEERING & SURVEYING
257 SOUTH COURT STREET
SUITE 6
MEDINA, OHIO 44256
PHONE: (330)723-1828
FAX: (330)723-6637
PROJECT No. 31,979

NOTE: BEARINGS ARE BASED ON
AN ASSUMED MERIDIAN AND ARE
USED TO DENOTE ANGLES ONLY.

MCL 4497
PPN 028-19B-11-028
MCL 4496
PLAT VOL. 19, PAGE 247
ROBERT A. BLOMQUIST &
KATHERINE J. BAILLIS
DOC. NO. 2003OR045480
08-26-2003

PPN 028-19B-11-027
MCL 2796
FOREST MEADOWS SUBD. NO. 6
PLAT VOL. 13, PAGE 4
RAYMOND A. & SANDRA S. TOMAZIC
DOC. NO. 1999OR028230
08-12-1999

LINDENWOOD LANE 60' R/W

T.P.O.B.

itZ
p. 5 of 5

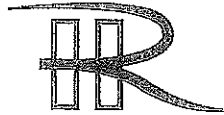

ROLLING & HOCEVAR
A Geo Innovation Group Affiliate

Engineering and Surveying
257 S. Court St. • Suite 6
Medina, Ohio 44256
Phone: 330-723-1828 • 800-723-1870
Fax: 330-723-6637
E-mail: info@rh-inc.com

Legal Description for Drainage Easement No. 2
Project No. 31,979
October 22, 2020

Situated in the City of Medina, County of Medina and State of Ohio, known as being part of Medina City Lot No. 4496, as recorded in Plat Volume 19, Page 247 of Medina County Recorder's Records, also being a part of land conveyed to Robert A. Blomquist and Katherine J. Bailis by deed recorded on August 26, 2003 in Document Number 2003OR045480 of Medina County Recorder's Records further bounded and described as follows:

Commencing at a 5/8-inch iron pin found without cap at the Southwest corner of said Medina City Lot No. 4496, the same being a point in the Northern line of Lindenwood Lane having a 60-foot wide right of way and the **TRUE PLACE OF BEGINNING** of the drainage easement herein described;

Thence along the Western line of said Medina City Lot No. 4496, bearing North 00° 47' 43" West, a distance of 27.80 feet to a point thereon;

Thence, bearing North 45°12'31" East, a distance of 60.69 feet to an angle point;

Thence, bearing South 44°47'29" East, a distance of 20.00 feet to a point in the Southern line of said Medina City Lot No. 4496;

Thence along the Southern line of said Medina City Lot No. 4496, bearing South 45°12'31" West, a distance of 80.00 feet to the Southwest corner of said Medina City Lot No. 4496 and the **TRUE PLACE OF BEGINNING**, containing 0.0323 acres (1,407 square feet) of land, more or less but subject to all legal highways and all covenants of record.

Bearings are based on an assumed meridian and are used herein to indicate angles only.

This legal description was prepared based on a survey under the supervision of Andrew G. Planet, P.S. No. S-7802 by Rolling & Hocevar, Inc. in October 2020.

Prepared for:
MEDINA CITY OF
132 N ELMWOOD AVE
MEDINA, OH 44256
Phone: 330-801-1499

Prepared by:
Greg Simonic
Valley Freightliner & Western Star
10901 Brookpark Rd
Parma, OH 44130
Phone: 216-267-4800
E-Mail: gsimonic@valley1.com

A proposal for
MEDINA CITY OF

Prepared by
Valley Freightliner & Western Star
Greg Simonic

May 05, 2021

Freightliner 108SD

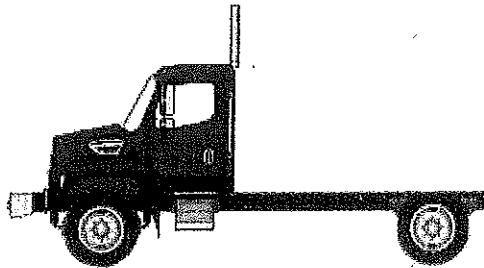

Components shown may not reflect all spec'd options and are not to scale



Prepared for:
 MEDINA CITY OF
 132 N ELMWOOD AVE
 MEDINA, OH 44256
 Phone: 330-801-1499

Prepared by:
 Greg Simonic
 Valley Freightliner & Western Star
 10901 Brookpark Rd
 Parma, OH 44130
 Phone: 216-267-4800
 E-Mail: gsimonic@valley1.com

S P E C I F I C A T I O N P R O P O S A L

Data Code	Description	Weight Front	Weight Rear
Price Level			
PRL-23D	SD PRL-23D (EFF:01/21/20)		
Data Version			
DRL-013	SPECPRO21 DATA RELEASE VER 013		
Interior Convenience/Driver Retention Package			
055-002	INTERIOR CONVENIENCE PACKAGE		
Vehicle Configuration			
001-176	108SD CONVENTIONAL CHASSIS	6,829	3,748
004-222	2022 MODEL YEAR SPECIFIED		
002-004	SET BACK AXLE - TRUCK		
019-002	STRAIGHT TRUCK PROVISION		
003-001	LH PRIMARY STEERING LOCATION		
General Service			
AA1-002	TRUCK CONFIGURATION		
AA6-002	DOMICILED, USA (EXCLUDING CALIFORNIA AND CARB OPT-IN STATES)		
A85-010	UTILITY/REPAIR/MAINTENANCE SERVICE		
A84-1GM	GOVERNMENT BUSINESS SEGMENT		
AA4-010	DIRT/SAND/ROCK COMMODITY		
AA5-002	TERRAIN/DUTY: 100% (ALL) OF THE TIME, IN TRANSIT, IS SPENT ON PAVED ROADS		
AB1-008	MAXIMUM 8% EXPECTED GRADE		
AB5-001	SMOOTH CONCRETE OR ASPHALT PAVEMENT - MOST SEVERE IN-TRANSIT (BETWEEN SITES) ROAD SURFACE		
995-1A0	FREIGHTLINER SD VOCATIONAL WARRANTY		
A66-99D	EXPECTED FRONT AXLE(S) LOAD : 16000.0 lbs		
A68-99D	EXPECTED REAR DRIVE AXLE(S) LOAD : 23000.0 lbs		
A63-99D	EXPECTED GROSS VEHICLE WEIGHT CAPACITY : 39000.0 lbs		
Truck Service			
AA3-018	FRONT PLOW/END DUMP BODY		



Prepared for:
 MEDINA CITY OF
 132 N ELMWOOD AVE
 MEDINA, OH 44256
 Phone: 330-801-1499

Prepared by:
 Greg Simonic
 Valley Freightliner & Western Star
 10901 Brookpark Rd
 Parma, OH 44130
 Phone: 216-267-4800
 E-Mail: gsimonic@valley1.com

Data Code	Description	Weight Front	Weight Rear
A88-99D	EXPECTED TRUCK BODY LENGTH : 0.0 ft		
AF3-1W0	HENDERSON		
Engine			
101-3BT	CUM L9 350 HP @ 2200 RPM; 2200 GOV RPM, 1050 LB-FT @ 1200 RPM		
Electronic Parameters			
79A-065	65 MPH ROAD SPEED LIMIT		
79B-000	CRUISE CONTROL SPEED LIMIT SAME AS ROAD SPEED LIMIT		
79K-007	PTO MODE ENGINE RPM LIMIT - 1100 RPM		
79M-001	PTO MODE BRAKE OVERRIDE - SERVICE BRAKE APPLIED		
79P-002	PTO RPM WITH CRUISE SET SWITCH - 700 RPM		
79Q-003	PTO RPM WITH CRUISE RESUME SWITCH - 800 RPM		
79S-001	PTO MODE CANCEL VEHICLE SPEED - 5 MPH		
79U-007	PTO GOVERNOR RAMP RATE - 250 RPM PER SECOND		
79V-001	FUEL DOSING OF AFTERTREATMENT ENABLED IN PTO MODE-CLEANS HYDROCARBONS AT HIGH TEMPERATURES ONLY		
80G-002	PTO MINIMUM RPM - 700		
80J-001	REGEN INHIBIT SPEED THRESHOLD - 0 MPH		
Engine Equipment			
99C-021	2016 ONBOARD DIAGNOSTICS/2010 EPA/CARB/GHG21 CONFIGURATION		
99D-010	NO 2008 CARB EMISSION CERTIFICATION		
13E-001	STANDARD OIL PAN		
105-001	ENGINE MOUNTED OIL CHECK AND FILL		
014-1C5	SIDE OF HOOD AIR INTAKE WITH FIREWALL MOUNTED DONALDSON AIR CLEANER AND INSIDE/OUTSIDE AIR WITH SNOW DOOR	10	
124-1D7	DR 12V 160 AMP 28-SI QUADRAMOUNT PAD ALTERNATOR WITH REMOTE BATTERY VOLT SENSE		
292-235	(2) DTNA GENUINE, FLOODED STARTING, MIN 2000CCA, 370RC, THREADED STUD BATTERIES		
290-017	BATTERY BOX FRAME MOUNTED		
281-001	STANDARD BATTERY JUMPERS		
282-001	SINGLE BATTERY BOX FRAME MOUNTED LH SIDE UNDER CAB		
291-017	WIRE GROUND RETURN FOR BATTERY CABLES WITH ADDITIONAL FRAME GROUND RETURN		
289-001	NON-POLISHED BATTERY BOX COVER		



Prepared for:
 MEDINA CITY OF
 132 N ELMWOOD AVE
 MEDINA, OH 44256
 Phone: 330-801-1499

Prepared by:
 Greg Simonic
 Valley Freightliner & Western Star
 10901 Brookpark Rd
 Parma, OH 44130
 Phone: 216-267-4800
 E-Mail: gsimonic@valley1.com

Data Code	Description	Weight Front	Weight Rear
87P-001	CAB AUXILIARY POWER CABLE	5	
293-058	POSITIVE LOAD DISCONNECT WITH CAB MOUNTED CONTROL SWITCH MOUNTED OUTBOARD DRIVER SEAT	8	
107-032	CUMMINS TURBOCHARGED 18.7 CFM AIR COMPRESSOR WITH INTERNAL SAFETY VALVE		
152-041	ELECTRONIC ENGINE INTEGRAL SHUTDOWN PROTECTION SYSTEM		
128-076	CUMMINS ENGINE INTEGRAL BRAKE WITH VARIABLE GEOMETRY TURBO ON/OFF	20	
016-1C2	RH OUTBOARD UNDER STEP MOUNTED HORIZONTAL AFTERTREATMENT SYSTEM ASSEMBLY WITH RH B-PILLAR MOUNTED VERTICAL TAILPIPE	30	25
28F-002	ENGINE AFTERTREATMENT DEVICE, AUTOMATIC OVER THE ROAD REGENERATION AND DASH MOUNTED REGENERATION REQUEST SWITCH		
239-026	10 FOOT 06 INCH (126 INCH+0/-5.9 INCH) EXHAUST SYSTEM HEIGHT		
233-017	STANDARD CURVE BRIGHT UPPER STACK(S)		
237-1CR	RH CURVED VERTICAL TAILPIPE B-PILLAR MOUNTED ROUTED FROM STEP		
23U-002	13 GALLON DIESEL EXHAUST FLUID TANK		
30N-003	100 PERCENT DIESEL EXHAUST FLUID FILL		
23Y-001	STANDARD DIESEL EXHAUST FLUID PUMP MOUNTING		
23Z-002	NON-POLISHED ALUMINUM DIAMOND PLATE DIESEL EXHAUST FLUID TANK COVER	15	5
43X-002	LH MEDIUM DUTY STANDARD DIESEL EXHAUST FLUID TANK LOCATION		
43Y-001	STANDARD DIESEL EXHAUST FLUID TANK CAP		
242-001	STAINLESS STEEL AFTERTREATMENT DEVICE/MUFFLER/TAILPIPE SHIELD		
273-018	HORTON DRIVEMASTER ADVANTAGE ON/OFF FAN DRIVE		
276-001	AUTOMATIC FAN CONTROL WITHOUT DASH SWITCH, NON ENGINE MOUNTED		
110-003	CUMMINS SPIN ON FUEL FILTER		
118-008	COMBINATION FULL FLOW/BYPASS OIL FILTER		
266-104	1115 SQUARE INCH ALUMINUM RADIATOR		
103-039	ANTIFREEZE TO -34F, OAT (NITRITE AND SILICATE FREE) EXTENDED LIFE COOLANT		
171-007	GATES BLUE STRIPE COOLANT HOSES OR EQUIVALENT		
172-001	CONSTANT TENSION HOSE CLAMPS FOR COOLANT HOSES		



Prepared for:
 MEDINA CITY OF
 132 N ELMWOOD AVE
 MEDINA, OH 44256
 Phone: 330-801-1499

Prepared by:
 Greg Simonic
 Valley Freightliner & Western Star
 10901 Brookpark Rd
 Parma, OH 44130
 Phone: 216-267-4800
 E-Mail: gsimonic@valley1.com

Data Code	Description	Weight Front	Weight Rear
270-016	RADIATOR DRAIN VALVE		
138-011	PHILLIPS-TEMRO 1000 WATT/115 VOLT BLOCK HEATER	4	
140-022	CHROME ENGINE HEATER RECEPTACLE MOUNTED UNDER LH DOOR		
132-004	ELECTRIC GRID AIR INTAKE WARMER		
155-058	DELCO 12V 38MT HD STARTER WITH INTEGRATED MAGNETIC SWITCH		

Transmission

342-582	ALLISON 3000 RDS AUTOMATIC TRANSMISSION WITH PTO PROVISION
---------	------------------------------------------------------------

Transmission Equipment

343-339	ALLISON VOCATIONAL PACKAGE 223 - AVAILABLE ON 3000/4000 PRODUCT FAMILIES WITH VOCATIONAL MODELS RDS, HS, MH AND TRV
84B-012	ALLISON VOCATIONAL RATING FOR ON/OFF HIGHWAY APPLICATIONS AVAILABLE WITH ALL PRODUCT FAMILIES
84C-023	PRIMARY MODE GEARS, LOWEST GEAR 1, START GEAR 1, HIGHEST GEAR 6, AVAILABLE FOR 3000/4000 PRODUCT FAMILIES ONLY
84D-023	SECONDARY MODE GEARS, LOWEST GEAR 1, START GEAR 1, HIGHEST GEAR 6, AVAILABLE FOR 3000/4000 PRODUCT FAMILIES ONLY
84E-013	S1 PERFORMANCE PRIMARY SHIFT SCHEDULE, AVAILABLE FOR 3000/4000 PRODUCT FAMILIES ONLY
84F-012	S1 PERFORMANCE SECONDARY SHIFT SCHEDULE, AVAILABLE FOR 3000/4000 PRODUCT FAMILIES ONLY
84G-005	1500 RPM PRIMARY MODE SHIFT SPEED
84H-011	1950 RPM SECONDARY MODE SHIFT SPEED
84U-000	DRIVER SWITCH INPUT - DEFAULT - NO SWITCHES
85F-094	MAXIMUM ENGINE SPEED FOR PTO OPERATION 5000 RPM
85H-159	MAXIMUM OUTPUT SPEED FOR PTO OPERATION 4000 RPM - ALLISON 5TH GEN TRANSMISSIONS
353-022	VEHICLE INTERFACE WIRING CONNECTOR WITHOUT BLUNT CUTS, AT BACK OF CAB
34C-001	ELECTRONIC TRANSMISSION CUSTOMER ACCESS CONNECTOR FIREWALL MOUNTED
362-823	CUSTOMER INSTALLED CHELSEA 280 SERIES PTO



Prepared for:
 MEDINA CITY OF
 132 N ELMWOOD AVE
 MEDINA, OH 44256
 Phone: 330-801-1499

Prepared by:
 Greg Simonic
 Valley Freightliner & Western Star
 10901 Brookpark Rd
 Parma, OH 44130
 Phone: 216-267-4800
 E-Mail: gsimonic@valley1.com

Data Code	Description	Weight Front	Weight Rear
363-001	PTO MOUNTING, LH SIDE OF MAIN TRANSMISSION		
341-018	MAGNETIC PLUGS, ENGINE DRAIN, TRANSMISSION DRAIN, AXLE(S) FILL AND DRAIN		
345-003	PUSH BUTTON ELECTRONIC SHIFT CONTROL, DASH MOUNTED		
97G-004	TRANSMISSION PROGNOSTICS - ENABLED 2013		
370-015	WATER TO OIL TRANSMISSION COOLER, IN RADIATOR END TANK		
346-013	TRANSMISSION OIL CHECK AND FILL WITH CROSSOVER TO CLEAR LH PTO AND DIRECT MOUNT PUMP		
35T-001	SYNTHETIC TRANSMISSION FLUID (TES-295 COMPLIANT)		

Front Axle and Equipment

400-1A9	DETROIT DA-F-16.0-5 16,000# FL1 71.0 KPI/3.74 DROP SINGLE FRONT AXLE	190	
402-030	MERITOR 16.5X6 Q+ CAST SPIDER CAM FRONT BRAKES, DOUBLE ANCHOR, FABRICATED SHOES	10	
403-002	NON-ASBESTOS FRONT BRAKE LINING		
419-023	CONMET CAST IRON FRONT BRAKE DRUMS		
427-001	FRONT BRAKE DUST SHIELDS	5	
409-006	FRONT OIL SEALS		
408-001	VENTED FRONT HUB CAPS WITH WINDOW, CENTER AND SIDE PLUGS - OIL		
416-022	STANDARD SPINDLE NUTS FOR ALL AXLES		
405-002	MERITOR AUTOMATIC FRONT SLACK ADJUSTERS		
406-001	STANDARD KING PIN BUSHINGS		
536-012	TRW TAS-85 POWER STEERING	40	
539-003	POWER STEERING PUMP		
534-003	4 QUART POWER STEERING RESERVOIR	5	
533-001	OIL/AIR POWER STEERING COOLER	5	
40T-002	CURRENT AVAILABLE SYNTHETIC 75W-90 FRONT AXLE LUBE		

Front Suspension

620-004	16,000# FLAT LEAF FRONT SUSPENSION	260	
619-004	GRAPHITE BRONZE BUSHINGS WITH SEALS - FRONT SUSPENSION		
62G-998	NO FRONT SUSPENSION OPTIONS		
410-001	FRONT SHOCK ABSORBERS		

Rear Axle and Equipment



Prepared for:
 MEDINA CITY OF
 132 N ELMWOOD AVE
 MEDINA, OH 44256
 Phone: 330-801-1499

Prepared by:
 Greg Simonic
 Valley Freightliner & Western Star
 10901 Brookpark Rd
 Parma, OH 44130
 Phone: 216-267-4800
 E-Mail: gsimonic@valley1.com

Data Code	Description	Weight Front	Weight Rear
420-051	RS-23-160 23,000# R-SERIES SINGLE REAR AXLE		180
421-563	5.63 REAR AXLE RATIO		
424-001	IRON REAR AXLE CARRIER WITH STANDARD AXLE HOUSING		
386-073	MXL 17T MERITOR EXTENDED LUBE MAIN DRIVELINE WITH HALF ROUND YOKES	20	20
452-001	DRIVER CONTROLLED TRACTION DIFFERENTIAL - SINGLE REAR AXLE		20
878-018	(1) DRIVER CONTROLLED DIFFERENTIAL LOCK REAR VALVE FOR SINGLE DRIVE AXLE		
87B-004	BLINKING LAMP WITH EACH MODE SWITCH, DIFFERENTIAL UNLOCK WITH IGNITION OFF, ACTIVE <5 MPH		
423-033	MERITOR 16.5X7 Q+ CAST SPIDER HEAVY DUTY CAM REAR BRAKES, DOUBLE ANCHOR, FABRICATED SHOES		
433-002	NON-ASBESTOS REAR BRAKE LINING		
434-011	BRAKE CAMS AND CHAMBERS ON FORWARD SIDE OF DRIVE AXLE(S)		
451-023	CONMET CAST IRON REAR BRAKE DRUMS		10
425-002	REAR BRAKE DUST SHIELDS		5
440-006	REAR OIL SEALS		
426-100	WABCO TRISTOP D LONGSTROKE 1-DRIVE AXLE SPRING PARKING CHAMBERS		
428-002	MERITOR AUTOMATIC REAR SLACK ADJUSTERS		
41T-002	CURRENT AVAILABLE SYNTHETIC 75W-90 REAR AXLE LUBE		
42T-001	STANDARD REAR AXLE BREATHER(S)		

Rear Suspension

N	622-1DF	30,000# FLAT LEAF SPRING REAR SUSPENSION WITH HELPER AND RADIUS ROD	160
	621-004	SPRING SUSPENSION - 1.50" AXLE SPACER	10
	431-001	STANDARD AXLE SEATS IN AXLE CLAMP GROUP	
	623-005	FORE/AFT CONTROL RODS	

Brake System

	490-100	WABCO 4S/4M ABS	
	871-001	REINFORCED NYLON, FABRIC BRAID AND WIRE BRAID CHASSIS AIR LINES	
	904-001	FIBER BRAID PARKING BRAKE HOSE	
	412-001	STANDARD BRAKE SYSTEM VALVES	
	46D-002	STANDARD AIR SYSTEM PRESSURE PROTECTION SYSTEM	



Prepared for:
 MEDINA CITY OF
 132 N ELMWOOD AVE
 MEDINA, OH 44256
 Phone: 330-801-1499

Prepared by:
 Greg Simonic
 Valley Freightliner & Western Star
 10901 Brookpark Rd
 Parma, OH 44130
 Phone: 216-267-4800
 E-Mail: gsimonic@valley1.com

Data Code	Description	Weight Front	Weight Rear
413-002	STD U.S. FRONT BRAKE VALVE		
432-003	RELAY VALVE WITH 5-8 PSI CRACK PRESSURE, NO REAR PROPORTIONING VALVE		
480-088	WABCO SYSTEM SAVER HP WITH INTEGRAL AIR GOVERNOR AND HEATER		
479-015	AIR DRYER FRAME MOUNTED		
460-007	ALUMINUM AIR BRAKE RESERVOIRS	-10	-15
607-001	CLEAR FRAME RAILS FROM BACK OF CAB TO FRONT REAR SUSPENSION BRACKET, BOTH RAILS OUTBOARD		
477-008	BW DV-2 AUTO DRAIN VALVE WITH HEATER - WET TANK		
485-003	QUICK DISCONNECT FITTING WITH TIRE INFLATION KIT	2	
Trailer Connections			
296-027	PRIMARY CONNECTOR/RECEPTACLE WIRED FOR COMBINATION STOP/TURN, CENTER PIN POWERED THROUGH IGNITION WITH STOP SIGNAL PREWIRE PACKAGE		
297-001	SAE J560 7-WAY PRIMARY TRAILER CABLE RECEPTACLE MOUNTED END OF FRAME	5	5
335-004	UPGRADED CHASSIS MULTIPLEXING UNIT		
Wheelbase & Frame			
545-427	4275MM (168 INCH) WHEELBASE		
546-102	7/16X3-9/16X11-1/8 INCH STEEL FRAME (11.11MMX282.6MM/0.437X11.13 INCH) 120KSI	170	150
548-803	BODY COMPANY INSTALLED ADDITIONAL FRONT FRAME REINFORCEMENT FOR SNOW PLOW		
552-039	1825MM (72 INCH) REAR FRAME OVERHANG		
55W-007	FRAME OVERHANG RANGE: 71 INCH TO 80 INCH	-20	100
549-002	24 INCH INTEGRAL FRONT FRAME EXTENSION	140	-20
AC8-99D	CALC'D BACK OF CAB TO REAR SUSP C/L (CA) : 102.76 in		
AE8-99D	CALCULATED EFFECTIVE BACK OF CAB TO REAR SUSPENSION C/L (CA) : 99.76 in		
AE4-99D	CALC'D FRAME LENGTH - OVERALL : 305.37		
FSS-0LH	CALCULATED FRAME SPACE LH SIDE : 38.99 in		
FSS-0RH	CALCULATED FRAME SPACE RH SIDE : 130.71 in		
AM6-99D	CALC'D SPACE AVAILABLE FOR DECKPLATE : 96.45 in		
553-001	SQUARE END OF FRAME		
550-001	FRONT CLOSING CROSSMEMBER		



Prepared for:
 MEDINA CITY OF
 132 N ELMWOOD AVE
 MEDINA, OH 44256
 Phone: 330-801-1499

Prepared by:
 Greg Simonic
 Valley Freightliner & Western Star
 10901 Brookpark Rd
 Parma, OH 44130
 Phone: 216-267-4800
 E-Mail: gsimonic@valley1.com

Data Code	Description	Weight Front	Weight Rear
559-003	LIGHTWEIGHT HEAVY DUTY ALUMINUM ENGINE CROSSMEMBER	-12	
562-001	STANDARD MIDSHIP #1 CROSSMEMBER(S)		
572-001	STANDARD REARMOST CROSSMEMBER		
565-001	STANDARD SUSPENSION CROSSMEMBER		
Chassis Equipment			
556-997	OMIT FRONT BUMPER, CUSTOMER INSTALLED SPECIAL BUMPER, DOES NOT COMPLY WITH FMCSR 393.203	-110	
558-001	FRONT TOW HOOKS - FRAME MOUNTED	15	
551-007	GRADE 8 THREADED HEX HEADED FRAME FASTENERS		
44Z-003	EXTERIOR HARNESSSES WRAPPED IN ABRASION TAPE & SECONDARY COVERING		
Fuel Tanks			
204-151	60 GALLON/227 LITER ALUMINUM FUEL TANK - LH		
218-006	25 INCH DIAMETER FUEL TANK(S)		
215-007	PLAIN ALUMINUM/PAINTED STEEL FUEL/HYDRAULIC TANK(S) WITH POLISHED STAINLESS STEEL BANDS		
212-007	FUEL TANK(S) FORWARD		
664-001	PLAIN STEP FINISH		
205-002	CHROME FUEL TANK CAP(S)		
122-1H7	DAVCO 245 FUEL/WATER SEPARATOR WITH WATER IN FUEL SENSOR	5	
216-020	EQUIFLO INBOARD FUEL SYSTEM		
202-016	HIGH TEMPERATURE REINFORCED NYLON FUEL LINE		
213-001	INSULATION FOR FUEL LINES	2	
Tires			
093-1RJ	MICHELIN X WORKS Z 315/80R22.5 20 PLY RADIAL FRONT TIRES	100	
094-1UX	MICHELIN X MULTI D 11R22.5 14 PLY RADIAL REAR TIRES		96
Hubs			
418-060	CONMET PRESET PLUS PREMIUM IRON FRONT HUBS		
450-060	CONMET PRESET PLUS PREMIUM IRON REAR HUBS		
Wheels			
502-356	ALCOA ULTRA ONE 89U64X 22.5X9.00 10-HUB PILOT 5.99 INSET ALUMINUM FRONT WHEELS	-28	



Prepared for:
 MEDINA CITY OF
 132 N ELMWOOD AVE
 MEDINA, OH 44256
 Phone: 330-801-1499

Prepared by:
 Greg Simonic
 Valley Freightliner & Western Star
 10901 Brookpark Rd
 Parma, OH 44130
 Phone: 216-267-4800
 E-Mail: gsimonic@valley1.com

Data Code	Description	Weight Front	Weight Rear
505-693	ALCOA LVL ONE 88267X 22.5X8.25 10-HUB PILOT ALUMINUM DISC REAR WHEELS		-112
524-022	POLISHED DISC SIDE FRONT WHEELS WITH DURA-BRIGHT FINISH		
525-023	POLISHED OUTER (DISHED SIDE) REAR WHEELS WITH OUTER ONLY DURA-BRIGHT FINISH		
Cab Exterior			
829-1A5	108 INCH BBC FLAT ROOF ALUMINUM CONVENTIONAL CAB		
650-008	AIR CAB MOUNTING		
705-012	CAB ROOF REINFORCEMENTS FOR ROOF MOUNTED COMPONENTS	2	
648-002	NONREMOVABLE BUGSCREEN MOUNTED BEHIND GRILLE		
667-037	SHORT FENDER WITH MUDFLAP		
754-017	BOLT-ON MOLDED FLEXIBLE FENDER EXTENSIONS	10	
678-067	SAFETY YELLOW LH AND RH INTERIOR GRAB HANDLES AND LH AND RH EXTERIOR GRAB HANDLES WITH SINGLE RUBBER INSERT		
645-002	BRIGHT FINISH RADIATOR SHELL/HOOD BEZEL		
646-042	STATIONARY BLACK GRILLE WITH BRIGHT ACCENTS		
65X-003	CHROME HOOD MOUNTED AIR INTAKE GRILLE		
644-004	FIBERGLASS HOOD		
727-1AF	SINGLE 14 INCH ROUND HADLEY AIR HORN UNDER LH DECK		
726-001	SINGLE ELECTRIC HORN		
728-001	SINGLE HORN SHIELD		
657-001	DOOR LOCKS AND IGNITION SWITCH KEYED THE SAME		
78G-002	KEY QUANTITY OF 2		
575-001	REAR LICENSE PLATE MOUNT END OF FRAME		
312-067	HALOGEN COMPOSITE HEADLAMPS WITH BRIGHT BEZELS		
302-047	LED AERODYNAMIC MARKER LIGHTS		
294-001	INTEGRAL STOP/TAIL/BACKUP LIGHTS		
300-015	STANDARD FRONT TURN SIGNAL LAMPS		
744-1BC	DUAL WEST COAST BRIGHT FINISH HEATED MIRRORS WITH LH AND RH REMOTE		
797-001	DOOR MOUNTED MIRRORS		
796-001	102 INCH EQUIPMENT WIDTH		



Prepared for:
 MEDINA CITY OF
 132 N ELMWOOD AVE
 MEDINA, OH 44258
 Phone: 330-801-1499

Prepared by:
 Greg Simonic
 Valley Freightliner & Western Star
 10901 Brookpark Rd
 Parma, OH 44130
 Phone: 216-267-4800
 E-Mail: gsimonic@valley1.com

Data Code	Description	Weight Front	Weight Rear
743-204	LH AND RH 8 INCH BRIGHT FINISH CONVEX MIRRORS MOUNTED UNDER PRIMARY MIRRORS		
729-001	STANDARD SIDE/REAR REFLECTORS		
677-055	RH AFTERTREATMENT SYSTEM CAB ACCESS WITH POLISHED DIAMOND PLATE COVER		
275-061	ELECTRIC HORN WARNING SYSTEM FOR PARK BRAKE NOT SET WITH DOOR OPEN AND ALL IGNITION KEY POSITIONS		
768-043	63X14 INCH TINTED REAR WINDOW		
661-004	TINTED DOOR GLASS LH AND RH WITH TINTED OPERATING WING WINDOWS		
654-027	RH AND LH ELECTRIC POWERED WINDOWS, PASSENGER SWITCHES ON DOOR(S)	4	
663-029	1-PIECE BONDED HEATED WIPER PARK SOLAR GREEN GLASS WINDSHIELD		
659-007	8 LITER (2 GAL) WINDSHIELD WASHER RESERVOIR, CAB MOUNTED, WITHOUT FLUID LEVEL INDICATOR		

Cab Interior

707-1AK	OPAL GRAY VINYL INTERIOR		
706-016	MOLDED DOOR PANEL WITH UPPER VINYL INSERTS		
708-016	MOLDED DOOR PANEL WITH UPPER VINYL INSERTS		
772-006	BLACK MATS WITH SINGLE INSULATION		
785-004	DASH MOUNTED ASH TRAY(S) WITHOUT LIGHTER		
691-014	FORWARD ROOF MOUNTED CONSOLE WITH UPPER STORAGE COMPARTMENTS AND ADDITIONAL CENTER COMPARTMENT WITHOUT NETTING		
742-007	(2) CUP HOLDERS LH AND RH DASH		
680-007	GRAY/CHARCOAL WING DASH		
860-004	SMART SWITCH EXPANSION MODULE		
720-002	2-1/2 LB. FIRE EXTINGUISHER	5	
700-002	HEATER, DEFROSTER AND AIR CONDITIONER		
701-008	STANDARD HVAC DUCTING WITH SNOW SHIELD FOR FRESH AIR INTAKE		
703-005	MAIN HVAC CONTROLS WITH RECIRCULATION SWITCH		
170-015	STANDARD HEATER PLUMBING		
130-041	VALEO HEAVY DUTY A/C REFRIGERANT COMPRESSOR		
702-002	BINARY CONTROL, R-134A		
739-034	PREMIUM INSULATION		



Prepared for:
 MEDINA CITY OF
 132 N ELMWOOD AVE
 MEDINA, OH 44256
 Phone: 330-801-1499

Prepared by:
 Greg Simonic
 Valley Freightliner & Western Star
 10901 Brookpark Rd
 Parma, OH 44130
 Phone: 216-267-4800
 E-Mail: gsimonic@valley1.com

Data Code	Description	Weight Front	Weight Rear
285-013	SOLID-STATE CIRCUIT PROTECTION AND FUSES		
280-007	12V NEGATIVE GROUND ELECTRICAL SYSTEM		
324-011	DOMED DOOR ACTIVATED LH AND RH, DUAL READING LIGHTS, FORWARD CAB ROOF		
655-005	LH AND RH ELECTRIC DOOR LOCKS		
284-101	(1) 12V POWER SUPPLY (1) DUAL 2.1 AMP USB CHARGER IN DASH		
722-002	TRIANGULAR REFLECTORS WITHOUT FLARES	10	
756-339	PREMIUM (L2) ISRI HIGH BACK AIR SUSPENSION DRIVERS SEAT WITH 2 AIR LUMBAR, INTEGRATED CUSHION EXTENSION, TILT AND ADJUSTABLE	70	
760-1DC	BASIC HIGH BACK NON SUSPENSION PASSENGER SEAT		
759-007	DUAL DRIVER SEAT ARMRESTS, NO PASSENGER SEAT ARMRESTS	4	
711-004	LH AND RH INTEGRAL DOOR PANEL ARMRESTS		
758-014	BLACK CORDURA PLUS CLOTH DRIVER SEAT COVER		
761-014	BLACK CORDURA PLUS CLOTH PASSENGER SEAT COVER		
763-101	BLACK SEAT BELTS		
532-002	ADJUSTABLE TILT AND TELESCOPING STEERING COLUMN	10	
540-015	4-SPOKE 18 INCH (450MM) STEERING WHEEL		
765-002	DRIVER AND PASSENGER INTERIOR SUN VISORS		

Instruments & Controls

732-003	WOODGRAIN DRIVER INSTRUMENT PANEL		
734-003	WOODGRAIN CENTER INSTRUMENT PANEL		
870-001	BLACK GAUGE BEZELS		
486-001	LOW AIR PRESSURE INDICATOR LIGHT AND AUDIBLE ALARM		
840-002	2 INCH PRIMARY AND SECONDARY AIR PRESSURE GAUGES		
198-002	INTAKE MOUNTED AIR RESTRICTION INDICATOR WITH GRADUATIONS		
721-001	97 DB BACKUP ALARM		3
149-017	ELECTRONIC CRUISE CONTROL WITH SWITCHES ON AUXILIARY GAUGE PANEL (B DASH PANEL)		
156-007	KEY OPERATED IGNITION SWITCH AND INTEGRAL START POSITION; 4 POSITION OFF/RUN/START/ACCESSORY		



Prepared for:
 MEDINA CITY OF
 132 N ELMWOOD AVE
 MEDINA, OH 44256
 Phone: 330-801-1499

Prepared by:
 Greg Simonic
 Valley Freightliner & Western Star
 10901 Brookpark Rd
 Parma, OH 44130
 Phone: 216-267-4800
 E-Mail: gsimonic@valley1.com

Data Code	Description	Weight Front	Weight Rear
811-042	ICU3S, 132X48 DISPLAY WITH DIAGNOSTICS, 28 LED WARNING LAMPS AND DATA LINKED		
160-038	HEAVY DUTY ONBOARD DIAGNOSTICS INTERFACE CONNECTOR LOCATED BELOW LH DASH		
844-001	2 INCH ELECTRIC FUEL GAUGE		
148-003	PROGRAMMABLE RPM CONTROL - ELECTRONIC ENGINE		
33U-007	CHASSIS MODULE JUMPER AND BRACKET FOR BODY BUILDER TO RELOCATE THE CHASSIS MODULE INTO THE CAB		
856-001	ELECTRICAL ENGINE COOLANT TEMPERATURE GAUGE		
864-001	2 INCH TRANSMISSION OIL TEMPERATURE GAUGE		
830-017	ENGINE AND TRIP HOUR METERS INTEGRAL WITHIN DRIVER DISPLAY		
372-051	CUSTOMER FURNISHED AND INSTALLED PTO CONTROLS		
852-002	ELECTRIC ENGINE OIL PRESSURE GAUGE		
N 679-001	OVERHEAD INSTRUMENT PANEL		
746-137	AM/FM/WB WORLD TUNER RADIO WITH BLUETOOTH, USB AND AUXILIARY INPUTS, J1939	10	
747-001	DASH MOUNTED RADIO		
750-002	(2) RADIO SPEAKERS IN CAB		
753-040	24 INCH AM/FM ANTENNA MOUNTED ON LH SIDE MIRROR, RG-62	2	
810-027	ELECTRONIC MPH SPEEDOMETER WITH SECONDARY KPH SCALE, WITHOUT ODOMETER		
817-001	STANDARD VEHICLE SPEED SENSOR		
812-001	ELECTRONIC 3000 RPM TACHOMETER		
162-002	IGNITION SWITCH CONTROLLED ENGINE STOP		
329-012	FOUR ON/OFF ROCKER SWITCHES IN THE DASH WITH INDICATOR LIGHTS AND WIRE ROUTED TO CHASSIS AT BACK OF CAB, LABEL OPT		
81Y-001	PRE-TRIP LAMP INSPECTION, ALL OUTPUTS FLASH, WITH SMART SWITCH		
836-015	DIGITAL VOLTAGE DISPLAY INTEGRAL WITH DRIVER DISPLAY		
660-025	SINGLE ELECTRIC WINDSHIELD WIPER MOTOR WITH DELAY PROGRAMMED TO SLOWEST SPEED WITH PARK BRAKE SET		



Prepared for:
 MEDINA CITY OF
 132 N ELMWOOD AVE
 MEDINA, OH 44256
 Phone: 330-801-1499

Prepared by:
 Greg Simonic
 Valley Freightliner & Western Star
 10901 Brookpark Rd
 Parma, OH 44130
 Phone: 216-267-4800
 E-Mail: gsimonic@valley1.com

Data Code	Description	Weight Front	Weight Rear
304-038	MARKER LIGHT SWITCH INTEGRAL WITH HEADLIGHT SWITCH AND SINGLE CONNECTOR AND SWITCH FOR CUSTOMER FURNISHED SNOW PLOW LIGHTS, LOW BEAMS OFF WITH HIGH BEAMS		
882-009	ONE VALVE PARKING BRAKE SYSTEM WITH WARNING INDICATOR		
299-013	SELF CANCELING TURN SIGNAL SWITCH WITH DIMMER, WASHER/WIPER AND HAZARD IN HANDLE		
298-039	INTEGRAL ELECTRONIC TURN SIGNAL FLASHER WITH HAZARD LAMPS OVERRIDING STOP LAMPS		

Design

065-000 PAINT: ONE SOLID COLOR

Color

980-5E1 CAB COLOR A: L0214EY RED ELITE EY
 986-020 BLACK, HIGH SOLIDS POLYURETHANE CHASSIS PAINT
 963-003 STANDARD E COAT/UNDERCOATING

Extended Front Axle Coverage

WA4-035 AXLE: DETROIT FRONT ONLY: HD MODERATE 5 YEARS/100,000 MILES/161,000 KM EXTENDED AXLE COVERAGE

Certification / Compliance

996-001 U.S. FMVSS CERTIFICATION, EXCEPT SALES CABS AND GLIDER KITS

Raw Performance Data

AE8-99D CALCULATED EFFECTIVE BACK OF CAB TO REAR SUSPENSION C/L (CA) : 99.76 in
 AM6-99D CALC'D SPACE AVAILABLE FOR DECKPLATE : 96.45 in

Sales Programs

NO SALES PROGRAMS HAVE BEEN SELECTED

TOTAL VEHICLE SUMMARY

Weight Summary

	Weight Front	Weight Rear	Total Weight
Factory Weight†	7842 lbs	4390 lbs	12232 lbs

Application Version 11.6.103
 Data Version PRL-23D.013
 Medina ODOT 023-21



Tender #
 05/05/2021 1:03 PM
 Page 14 of 25

Prepared for:
 MEDINA CITY OF
 132 N ELMWOOD AVE
 MEDINA, OH 44256
 Phone: 330-801-1499

Prepared by:
 Greg Simonic
 Valley Freightliner & Western Star
 10901 Brookpark Rd
 Parma, OH 44130
 Phone: 216-267-4800
 E-Mail: gsimonic@valley1.com

Dealer Installed Options	0 lbs	0 lbs	0 lbs
Total Weight ⁺	7842 lbs	4390 lbs	12232 lbs

Extended Warranty

WAI-47H	CUM 2017 L9: HD1 MD DTY 5 YEARS / 100,000 MILES / 161,000 KM EXTENDED WARRANTY. FEX APPLIES
WAX-101	CUM 2017 L9: AT3 MD DTY 5 YEARS / 100,000 MILES / 161,000 KM AFTERTREATMENT. FEX APPLIES
WBB-344	TC4: MD MODERATE 5 YEARS/100,000 MILES / 161,000 KM EXTENDED TRUCK COVERAGE. FEX APPLIES
WAL-231	AXLE: NON-DETROIT SINGLE REAR ONLY: MD MODERATE 5 YEARS/100,000 MILES/161,000 KM EXTENDED COVERAGE

Dealer Installed Options

		Weight Front	Weight Rear	
TCM	RELOCATE TRANSMISSION CONROL MODULE (TCM) INSIDE CAB	0	0	\$675
PDM	RELOCATE CHASSIS POWER DISTRIBUTION MODULE (PDM) INSIDE OF CAB	0	0	\$360
HDN	SEE HENDESON SPECIFICATIONS	0	0	\$82,521
FLMT	WEATHERTECH OR SIMILAR FRONT LH & RH FLOORMATS	0	0	\$325
Total Dealer Installed Options		0 lbs	0 lbs	

(+) Weights shown are estimates only.
 If weight is critical, contact Customer Application Engineering.

(***) All cost increases for major components (Engines, Transmissions, Axles, Front and Rear Tires) and government mandated requirements, tariffs, and raw material surcharges will be passed through and added to factory invoices.



Prepared for:
MEDINA CITY OF
132 N ELMWOOD AVE
MEDINA, OH 44256
Phone: 330-801-1499

Prepared by:
Greg Simonic
Valley Freightliner & Western Star
10901 Brookpark Rd
Parma, OH 44130
Phone: 216-267-4800
E-Mail: gsimonic@valley1.com



HENDERSON

PRODUCTS, INC.

2177 STATE ROUTE 19
BUCYRUS, OH 44820
PHONE: 419-617-7509
FAX: 563-927-7105

CUSTOMER QUOTE

Page 1
Quote #146914
Rev #51

TO: VALLEY FREIGHTLINER STERLING
Attn: GREG SIMONIC
Quote Date: 5/5/2021
Valid Until: 5/1/2021

Quoted By: Ross Rapp
Phone: 419-617-7509
Cell: 4195696155
Fax:
Email: rrepp@hendersonproducts.com

Quoted:
CITY OF MEDINA SINGLE AXLE SNOW & ICE CONTROL TRUCK EQUIPMENT PACKAGE

Henderson Products is pleased to present the following quote. Please contact us if you have any questions.

Reversible snow plow

Plow Length: 11' length
Moldboard Trip: Adjustable cutting edge trip - torsion spring
PushFrame Type: Heavy Duty Outboard cylinders Type
Moldboard Height: 42" height
Moldboard Shield: Integral shield
Moldboard Sheet Material: 10 GA GR50 steel (standard)
Adjustable Trip Spring: Adjustable cutting edge trip springs
Hydraulic Cylinders: 3" x 15" single acting nitrated reversing cylinders
Paint: Henderson Orange
12" Rubber Deflector: Yes, w/ SS Backer
Install Rubber Deflector: Yes
36" Plastic Side Markers, Pair: Yes
Parking Jack, Screw Adjustable: Yes
Install Parking Jack: Yes
Cutting Edge: Std 5/8" x 8" One Piece AASHTO punch
Hitch, Plow Portion: Pin and loop oscillating hitch
Plow Portion Installed on Plow: Yes
Hitch, Truck Portion: See MPH or HCH for Truck portion hitch
Custom Option Fields: Note Custom Details Below
Option 1 Description: MOLDBOARD WITH ORANGE FACE, FLAT BLACK BACK
Option 2 Description: IDC-OH LOW PRO PIN & LOOP HITCH #156042
Option 3 Description: ALL STRUCTURAL STEEL CONSTRUCTION
Option 4 Description: TELESCOPIC LIPT BEAM FOLDS FLAT WHEN NOT IN USE
Option 5 Description:
Option 6 Description:

MARKER SA Dump Body

BODY LENGTH: 10ft BODY LENGTH
SIDE STYLE: STRAIGHT SIDES
SIDE HEIGHT (FROM FLOOR): 30" SIDE HEIGHT
REAR BODY PROFILE: STANDARD STRAIGHT VERTICAL GATE
REAR CORNER POSTS: REAR BOLSTERS 8" ABOVE SIDES
BOARD POCKETS: 2" WIDE BOARD POCKETS

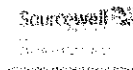

Prepared for:
MEDINA CITY OF
132 N ELMWOOD AVE
MEDINA, OH 44256
Phone: 330-801-1499

Prepared by:
Greg Simonic
Valley Freightliner & Western Star
10901 Brookpark Rd
Parma, OH 44130
Phone: 216-267-4800
E-Mail: gsimonic@valley1.com



HENDERSON

PRODUCTS, INC.

2177 STATE ROUTE 19
BUCYRUS, OH 44820
PHONE: 419-617-7509
FAX: 563-927-7106

CUSTOMER QUOTE

Page 2
Quote #146814
Rev #51

HOIST TYPE: TRN MOUNT TELE HOIST W/ SUBFRM, INTERNAL DOGHOUSE
HOIST CYLINDER/MODEL: MAILHOT CS-SERIES, DOUBLE ACTING, CS90-4.5-3DA
HYDRAULIC PUMP: NO FACTORY SUPPLIED HYDRAULIC PUMP
CYLINDER CRADLE STYLE: STANDARD HOIST CRADLE
INSTALL SUBFRAME AND/OR CYLINDER: SHIP LOOSE - DEALER TO INSTALL
EXTRA BODY PROP: NO EXTRA BODY PROP
HYDRAULIC RESERVOIR: NO RESERVOIR - DEALER TO SUPPLY
FLOOR MATERIAL: 1/4" AR400 FLOOR
FLOOR TO SIDE RADIUS: 5" RADIUS FLOOR TO SIDE
LONGSILL MATERIAL: 5" I-BEAM LONGSILLS (STANDARD SKIP WELD)
SIDES/HEADSHEET MATERIAL: 10GA 201SS SIDES/HEAD
SIDE BRACING TYPE: SINGLE WELD-ON INTERMEDIATE SIDE BRACE
SIDE BRACE MATERIAL: 10GA 201SS SIDE BRACING
TOP RAIL STYLE: FLAT (2" FLAT, THEN SLOPED)
CONTOURED FRONT CORNER POSTS: 10GA 201SS FRONT CORNER POSTS
REAR CORNER POST MATERIAL: 7GA 201SS REAR CORNER POSTS
TAILGATE STYLE: STANDARD TAILGATE
TAILGATE SHEET MATERIAL: 10GA 201SS TAILGATE SHEET
TAILGATE BRACING: DOUBLE HORIZONTAL TAILGATE BRACING
TAILGATE BRACE MATERIAL: 10GA 201SS TAILGATE BRACING
TAILGATE TOP PIVOT HARDWARE: 1-1/4" PINS, 1" PLATES, GREASABLE
TAILGATE LATCH TYPE: MANUAL TAILGATE RELEASE, GREASABLE SS BUSHINGS
TAILGATE RELEASE VALVE: NO TAILGATE RELEASE VALVE
TAILGATE PIN LANYARDS: NO TAILGATE PIVOT PIN LANYARDS
TAILGATE LIFT LOOP: TAILGATE LIFT LOOP, CENTER OUTSIDE (SS)
LATCH JAWS: LOWER TO LATCH JAWS, GREASABLE
COAL CHUTE: COAL CHUTE
COAL CHUTE TYPE: STD 13.5" COAL CHUTE (201SS)
COAL CHUTE QUANTITY: TRIPLE COAL CHUTES
COAL CHUTE INSTALLED: COAL CHUTES INSTALLED
COAL CHUTE LOCATION: LEFT/CENTER/RIGHT
REAR FACE LIGHT HOLES: (3) OBROUND LIGHT HOLES, EA BOLSTER REAR FACE
REAR SIDE MARKER LIGHT HOLE: STD 2.5" SIDE MARKER LIGHT HOLES
EXTERIOR LIGHT BOXES INSTALLED: NO EXTERIOR LIGHT BOXES
LIGHTING PACKAGE: NO OEM LIGHTING PACKAGE
BODY HINGE CONSTRUCTION: STD SUBFRAME INTEGRAL HINGE
BODY HINGE TYPE: GREASABLE HINGE BLOCKS
BODY HINGE PAINT: YES, REAR HINGE PAINTED @ FACTORY
PAINT PREPARATION: SS WASH-NATURAL FINISH, PRIME MILD PARTS (201/304SS BODY)
CABSHIELD STYLE: STANDARD WELD ON CABSHIELD
CABSHIELD MATERIAL: 10GA W/ 7GA END PLATES (201SS)
CABSHIELD SIZE: 22" X 86" CABSHIELD (1/2 CAB)
CABSHIELD MOUNTED LIGHT HOLES: FOUR OVALS, (1) FACING EACH SIDE, (2) FACING FORWARD
INSTALL CABSHIELD: CABSHIELD SHIPPED LOOSE, DEALER TO INSTALL
ASPHALT LIP: NO ASPHALT LIP
WALK RAIDS: WALK RAIL INSTALLED ON LOWER RAILRAILS
WALKRAIL MATERIAL: STAINLESS STEEL WALKRAIL MATERIAL
WALK RAIL TYPE: 1-1/2" GRIP STRUT (304SS)

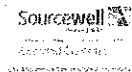

Prepared for:
MEDINA CITY OF
132 N ELMWOOD AVE
MEDINA, OH 44256
Phone: 330-801-1499

Prepared by:
Greg Simonic
Valley Freightliner & Western Star
10901 Brookpark Rd
Parma, OH 44130
Phone: 216-267-4800
E-Mail: gsimonic@valley1.com



HENDERSON

PRODUCTS, INC.

2177 STATE ROUTE 19
BUCYRUS, OH 44320
PHONE: 419-617-7509
FAX: 563-927-7106

CUSTOMER QUOTE

Page 3
Quote #146814
Rev #51

TARP RAILS: NO TARP RAILS
SIDE LADDERS: (YES) SIDE LADDER - Pick From List Below
SIDE LADDER MATERIAL: STAINLESS STEEL LADDER CONSTRUCTION - Pick From List Below
DRIVER'S SIDE FRONT LADDER: 3 STEP PULL OUT LADDER (201SS)
INSTALL DRIVER SIDE FRONT LADDER: NO, SHIP DRIVERS SIDE FRONT LADDER LOOSE
DRIVER'S SIDE REAR LADDER: NO DRIVERS SIDE REAR LADDER
CURBSIDE FRONT LADDER: NO CURBSIDE FRONT LADDER
CURBSIDE REAR LADDER: NO CURB SIDE REAR LADDER
STEP(S): NO STEP(S)
GRAB HANDLES: NO GRAB HANDLES
Show Options: No Additional Options
Option 1 Description: 6 CS LIGHT HOLES - 2 FWD, 2 REAR, 1 EACH SIDE
Option 2 Description: CENTER AND LEFT COAL CHUTE HANDLES TO DS, RIGHT TO PS
Option 3 Description: EXTENDED CENTER COAL CHUTE HANDLE TO DS

RTS - Replacement tailgate spreader

SPREADER & AUGER MATERIAL: 304SS
Option 1 Description: 201 STAINLESS STEEL CONSTRUCTION
Option 2 Description: RTS TO FIT MRE 38 INCH TALL TAILGATE

Installation Workup

Facility: IDC-OR
Chassis Delivery To Henderson: Truck Dealer/Customer Delivers
Completed Truck Delivery Method: Henderson Delivers (100 miles or less)
Chassis Make: Freightliner
Chassis Model Yr: 2022
Chassis Model: M2 108
Useable CA/CT: 102 INCH CA. REQUIREMENT
Front Frame Ext?: Yes
Front Frame Ext Type: Full
Front Frame Wall: Single Wall
Front Frame Width: 34"
Pump Location: Front Mount Pump (REQUIRES FRONT CRANKSHAFT PROVISION)
Transmission Type: Automatic
Transmission Model: Allison Transmission
Set Back Axis: Yes

Hitch Type: Low Profile or Manual Tilt Type Hitch
Mount Type: Cheek Plate Mount Kit (Select type below)
Mount Kit Model (Req'd): Low Pro/MT CK 91t Kit (No Mng, 34"w Full Frame)
Front Bumper: Fabricated Channel Bumper (2po design) (MFG Material)
Front Tow Hooks: Tow Hooks, 44,000 lb, Pair (installed front of chassis)

Front Plow Type: Standard Henderson Plow
Plow Markers (Front Plow): IDC Install of fact supplied markers, sales to order w/ unit

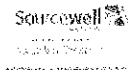

Prepared for:
MEDINA CITY OF
132 N ELMWOOD AVE
MEDINA, OH 44256
Phone: 330-801-1499

Prepared by:
Greg Simonic
Valley Freightliner & Western Star
10901 Brookpark Rd
Parma, OH 44130
Phone: 216-267-4800
E-Mail: gsimonic@valley1.com



HENDERSON

PRODUCTS, INC.

2177 STATE ROUTE 19
BUJCYRUS, OH 44820
PHONE: 419-617-7509
FAX: 563-927-7106

CUSTOMER QUOTE

Page 4
Quote #145814
Rev #51

Rubber Deflector Install: Supplied/Installed @ Factory, sales to order w/ unit
Plow Jack Install: Supl'd/Instl'd on plow @ Factory, Sales order with unit

Dump Body Type: Mark E Single Axle
Floor Length: (10') Floor length
Hoist Type: Tala Trum Hoist with Subframe, Internal Doghouse
Cylinder Type: Double Acting
Body Material (Sides/ends): Stainless Steel Type Body Material
Tailgate Release Type: Manual Tailgate Release
Cabshield Install: Supl'd by fact, welded to body @ IDC, sales to order w/ unit
Step(s): Supplied and install @ IDC (select from step options below)
Step QTY: 1
Step 1 Type: SS Serrated 18" Step (For Flat Surface)
Step 1 Location: Driver Side Front, Inside
Grab Handle(s): (2) IDC supplied/installed grab handles (select type below)
Grab Handle 1 Type: SS 17" grab handle
Grab Handle 2 Type: SS 17" grab handle
Ladder(s): Supplied by factory, Install @ IDC (sales to order w/ unit)
Ladder Install QTY (Dump): (1) LADDER INSTALLED @ IDC (LABOR ONLY)
Ladder Install Style (Dump) 1: 3 Step Pull Out
Ladder Install Loc 1 (Dump): Driver Side Front
Shovel Holder: (1) IDC Supl'd Spring Loaded SS Shovel Holder w/ SS brokt
Shovel Holder Loc (1): Driver side body
Body Install Options 1: SHOVEL HOLDER ATTACHED TO BEHIND CAB BRINE TANK

Body Spec Notes:

Spreader Type: RTS
RTS Drive Type: Hydraulic Drive
RTS Spinner Configuration: Single Spinner Install
HYD QD Mount Brackets: Stainless Steel QD Mount in front of dump body bolster

Prewet/Liquid System: Frame Mount Prewet System
Configuration: IDC Supplied (sales to quote from vendor)
Vendor Supplied Kit: CERTIFIED POWER
Install Location: Cradle Mount (verify fit or CA/CT if Req'd)
Drive Configuration: Hydraulic Drive, Vendor Supplied (sales to quote w/ hyd)
Controls: Supplied by IDC (sales to order w/ hyd entrie)
Liquid Options 1: 240 GALLON BEHIND THE CAB LIQUID TANK SYSTEM
Liquid Options 2: PRE-WET SPRAY AT THE SPINNER

Liquid Details:

Chassis Accessories: Yes (SELECT RELATED OPTIONS BELOW)
Mudflaps (Rear): Swinging w/Logo
Mudflap Type (Rear): 36" Swinging, SS (with LOGO)
Fenders: Poly fenders, Full Pair, single axle, SS mount



Prepared for:
MEDINA CITY OF
132 N ELMWOOD AVE
MEDINA, OH 44256
Phone: 330-801-1499

Prepared by:
Greg Simonic
Valley Freightliner & Western Star
10901 Brookpark Rd
Parma, OH 44130
Phone: 216-267-4800
E-Mail: gsimonic@valley1.com



HENDERSON

PRODUCTS, INC.

2177 STATE ROUTE 19
SUCYRUS, OH 44820
PHONE: 419-617-7509
FAX: 563-927-7106

CUSTOMER QUOTE

Page 5
Quote #146814
Rev #51

Pintle Plate: Yes (select from options below)
Pintle Plate Configuration: 3/4" Plate, PH20/45 Holes, SA w/ SubFrm (3LTC)
Pintle Plate D-Rings: Qty (2) 1" D-rings, 50 deg bend
Pintle Hook: 30 Ton
Trailer Plug (1): 7 Pin Trailer Plug, Truck and 7-Way RV, new style (municipal)
Lube System: Auto Lube System - Supplier Install (Price Below)
Spec Lube System: GROENEVELD CENTRAL LUBE SYSTEM
Truck Wash: Complete Truck Wash/Clean/Vac 1
Warranty: Standard 1 Year Warranty
Inspection: Walk-around meeting only
Reflective Tape: Reflective Tape, Henderson Logo (60' Linear)
Install Touch-up: Basic Installation Touch-Up

Electrical: Yes (SELECT RELATED OPTIONS BELOW)
Power Distribution Panel: Power Distribution Panel
Misc Electrical Supplies: Req'd Misc Elect Supplies
PLOW Lights: Plow Lts, Halogen, Trucklits All Chassis, (PAIR)
PLOW Light Brackets: Plow Lt Brckts, SS, FRTLRN/Western Star/Other, Pair
Worklight(s) QTY: (QTY 1) Work Light (Select type below)
Worklight (1) Type: LED, Worklight, 4in Round (Optilux)
Worklight (1) Gen Location: Rear Spinner
Cabshield Warning Light Qty: Qty 6 Lights (Order Holes with Unit)
Cabshield Warning Lights: QTY 6, 6" LED Oval Strobes, Amber (order holes w/unit)
Cabshield Lighting Harness: Cabshield Warning Lights Only (qty 2-6)
Rear Dump Solster (S/T/T): LED S/T/T. kit (OR) (order holes)
OEM Light Remount: Remount OEM Chassis Lights
Rear Dump Solster (Back-up): B/U Lights, LED, Clear, Oval, pair (Order holes with body)
Rear Dump Solster Strobes: 6" LED Oval Strobes, Amber, 1 PR, (order holes w/unit)
Back up alarm: Backup Alarm, 97db
Junction Box/Backup Alarm Bracket: Backup Alarm Bracket Installed
Body up switch/light: Body UP Switch/Body Up Light (Trucklite)
Brake controller: Brake Controller, Voyager Brake Controller
Backbone & Wire Standoffs: 10' Backbone (For SA)

Electrical Spec Notes:

Hydraulics: Full Hydraulic Package
Hyd Supplier: Certified (Select Pkg Below)
Hyd Supplier (Spec): CERTIFIED POWER QTN 19341842
Controls Type: Cable Controls
Cable Qty: 3 Functions
PTO Type: Included in Hydraulics Package
Reservoir Type: Supplied With Hydraulics
Valve Enclosure Type: Supplied With Hydraulics
Low Oil Indicator: Yes, included in Hyd Pkg
SS Tubing Upgrade: SA, FAR lines, 6' Frnt, 9'Rr

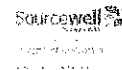

Prepared for:
MEDINA CITY OF
132 N ELMWOOD AVE
MEDINA, OH 44256
Phone: 330-801-1499

Prepared by:
Greg Simonic
Valley Freightliner & Western Star
10901 Brookpark Rd
Parma, OH 44130
Phone: 216-267-4800
E-Mail: gsimonic@valley1.com



HENDERSON

PRODUCTS, INC.

2177 STATE ROUTE 19
BUCYRUS, OH 44820
PHONE: 419-617-7509
FAX: 563-927-7106

CUSTOMER QUOTE

Page 6
Quote #146814
Rev #51

Quick Coupler Upgrade: Standard Quick Couplers
Hyd Options 1: STAINLESS STEEL VALVE ENCLOSURE/OIL RESERVOIR COMBO
Hyd Options 2: FRONT CRANKSHAFT DRIVEN PUMP
Hyd Options 3: PRE-WET PUMP BOX

Hydraulics Notes:

IDC Paint Location: IDC-OH
Undercoat: Undercoat (Body Underside & Chassis)
Paint Code & Color (from color charts):

Single Package: \$82,521.00
Package(s) : 1
Total: \$82,521.00

Due to current raw material market conditions this quote includes a surcharge on Henderson equipment. Quotes exceeding the expressed quote validity date are subject to surcharge revisions.

Signed: _____ Date: _____

Quote notes:



Prepared for:
 MEDINA CITY OF
 132 N ELMWOOD AVE
 MEDINA, OH 44256
 Phone: 330-801-1499

Prepared by:
 Greg Simonic
 Valley Freightliner & Western Star
 10901 Brookpark Rd
 Parma, OH 44130
 Phone: 216-267-4800
 E-Mail: gsimonic@valley1.com

D I M E N S I O N S

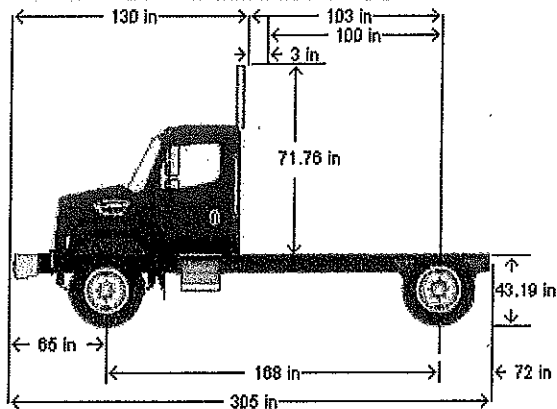

VEHICLE SPECIFICATIONS SUMMARY - DIMENSIONS

Wheelbase (545)	4275MM (168 INCH) WHEELBASE
Rear Frame Overhang (552)	1825MM (72 INCH) REAR FRAME OVERHANG
Fifth Wheel (578)	NO FIFTH WHEEL
Mounting Location (577)	NO FIFTH WHEEL LOCATION
Maximum Forward Position (in)	0
Maximum Rearward Position (in)	0
Amount of Slide Travel (in)	0
Slide Increment (in)	0
Desired Slide Position (in)	0.0
Cab Size (829)	108 INCH BBC FLAT ROOF ALUMINUM CONVENTIONAL CAB
Sleeper (882)	NO SLEEPER BOX/SLEEPER CAB
Exhaust System (016)	RH OUTBOARD UNDER STEP MOUNTED HORIZONTAL AFTERTREATMENT SYSTEM ASSEMBLY WITH RH B-PILLAR MOUNTED VERTICAL TAILPIPE

TABLE SUMMARY - DIMENSIONS



Prepared for:
 MEDINA CITY OF
 132 N ELMWOOD AVE
 MEDINA, OH 44256
 Phone: 330-801-1499

Prepared by:
 Greg Simonic
 Valley Freightliner & Western Star
 10901 Brookpark Rd
 Parma, OH 44130
 Phone: 216-267-4800
 E-Mail: gsimonic@valley1.com

Dimensions	Inches
Bumper to Back of Cab (BBC)	130.1
Bumper to Centerline of Front Axle (BA)	64.6
Min. Cab to Body Clearance (CB)	3.0
Back of Cab to Centerline of Rear Axle(s) (CA)	102.8
Effective Back of Cab to Centerline of Rear Axle(s) (Effective CA)	99.8
Back of Cab Protrusions (Exhaust/Intake) (CP)	2.0
Back of Cab Protrusions (Side Extenders/Trim Tab) (CP)	0.0
Back of Cab Protrusions (CNG Tank)	0.0
Back of Cab Clearance (CL)	3.0
Back of Cab to End of Frame	174.7
Cab Height (CH)	71.8
Wheelbase (WB)	168.3
Frame Overhang (OH)	71.9
Overall Frame Length	305.4
Overall Length (OAL)	304.8
Rear Axle Spacing	0.0
Unladen Frame Height at Centerline of Rear Axle	43.2

Performance calculations are estimates only. If performance calculations are critical, please contact Customer Application Engineering.



Prepared for:
 MEDINA CITY OF
 132 N ELMWOOD AVE
 MEDINA, OH 44256
 Phone: 330-801-1499

Prepared by:
 Greg Simonic
 Valley Freightliner & Western Star
 10901 Brookpark Rd
 Parma, OH 44130
 Phone: 216-267-4800
 E-Mail: gsimonic@valley1.com

Q U O T A T I O N

108SD CONVENTIONAL CHASSIS

SET BACK AXLE - TRUCK CUM L9 350 HP @ 2200 RPM; 2200 GOV RPM, 1050 LB-FT @ 1200 RPM ALLISON 3000 RDS AUTOMATIC TRANSMISSION WITH PTO PROVISION RS-23-160 23,000# R-SERIES SINGLE REAR AXLE 30,000# FLAT LEAF SPRING REAR SUSPENSION WITH HELPER AND RADIUS ROD DETROIT DA-F-16.0-5 16,000# FL1 71.0 KPI/3.74 DROP SINGLE FRONT AXLE	16,000# FLAT LEAF FRONT SUSPENSION 108 INCH BBC FLAT ROOF ALUMINUM CONVENTIONAL CAB 4275MM (168 INCH) WHEELBASE 7/16X3-9/16X11-1/8 INCH STEEL FRAME (11.11MMX282.6MM/0.437X11.13 INCH) 120KSI 1825MM (72 INCH) REAR FRAME OVERHANG BODY COMPANY INSTALLED ADDITIONAL FRONT FRAME REINFORCEMENT FOR SNOW PLOW
----------------------------------------------------------------------------------------------------------------------------------------------------------------------------------------------------------------------------------------------------------------------------------------------------------------------------------------------------	--------------------------------------------------------------------------------------------------------------------------------------------------------------------------------------------------------------------------------------------------------------------------------------------------------------------------------

		PER UNIT	TOTAL
VEHICLE PRICE	TOTAL # OF UNITS (2)	\$ 84,553	\$ 169,106
EXTENDED WARRANTY		\$ 3,650	\$ 7,300
DEALER INSTALLED OPTIONS		\$ 83,881	\$ 167,762
CUSTOMER PRICE BEFORE TAX		\$ 172,084	\$ 344,168

TAXES AND FEES

TAXES AND FEES	\$	0	\$ 0
OTHER CHARGES	\$	0	\$ 0

TRADE-IN

TRADE-IN ALLOWANCE	\$	(0)	\$ (0)
--------------------	----	-----	--------

BALANCE DUE	(LOCAL CURRENCY) \$	172,084	\$ 344,168
-------------	---------------------	---------	------------

Chassis pricing based under Ohio Department of Transportation contract 023-21 cooperative pricing with selected or standard truck warranty. Pricing is valid for Ohio municipal purchases and eligibility coincides with contract terms and dates. It is the responsibility of the purchasing entity to request and determine eligibility of cooperative purchases. A purchase order to this proposal thereby agrees to the pricing, specifications, and terms the cooperative contract unless other arrangements are agreed upon. If an order, please consult with your body builder to assure all dimensions and necessary chassis components are included the specification. All specifications and pricing are subject to final engineering review. Invoicing will occur upon delivery of bare chassis to customer or location of customer's choice. Payment is due upon receipt of invoice. Titles will be transferred and delivered promptly upon receipt of payment.

APPROVAL:

Please indicate your acceptance of this quotation by signing below:

Customer: X _____ Date: ___ / ___ / ___.



Prepared for:
MEDINA CITY OF
132 N ELMWOOD AVE
MEDINA, OH 44256
Phone: 330-801-1499

Prepared by:
Greg Simonic
Valley Freightliner & Western Star
10901 Brookpark Rd
Parma, OH 44130
Phone: 216-267-4800
E-Mail: gsimonic@valley1.com



OHIO DEPARTMENT OF TRANSPORTATION

CENTRAL OFFICE - 1950 WEST BROAD STREET - COLUMBUS, OH 43223
MIKE DEWINE, GOVERNOR - JACK MARCHBANKS, PH.D., DIRECTOR

August 26, 2020

Valley Freightliner Sterling and Western Star, Inc
10901 Brook Park Rd.
Parma, OH 44130

Re: 023-21
Single & Tandem Axle Cab and Chassis

Dear Vendor:

Your bid proposal as submitted has been accepted by the Ohio Department of Transportation.

This invitation permits multiple awarded vendors to provide Single & Tandem Axle Cab and Chassis.
The contract will be in effect from September 1, 2020 to August 31, 2021.

A purchase shall only take place upon the issuance of an official purchase order or the use of a payment card. There is no guarantee that purchase orders will be issued or that products will be ordered against issued purchase orders.

Thank you for bidding on our invitation. Jim Schurch is available for any assistance necessary to ensure that a quality partnership exists between your company and our Department. If you have any questions, please call (614) 644-7870 or (800) 459-3778.

Respectfully,

A handwritten signature in black ink, appearing to read "Jack Marchbanks".

Jack Marchbanks, Ph.D.
Director
Ohio Department of Transportation

OK
Dennis Hanwell
6-23-2021

REQUEST FOR COUNCIL ACTION

No. RCA 21-141-6/28

FROM: Mayor Dennis Hanwell
DATE: June 23, 2021
SUBJECT: Restoration of 10% budget cuts

Committee: Finance

SUMMARY AND BACKGROUND:

Respectfully request Council restore funds that were cut (10% reduction) from 2020 budget due to concerns of lower tax revenue due to COVID-19. Restoration requested for the following:

- Building Department 001-0430
- Cable TV Fund 144-0730
- Cemetery Department 001-0210
- Economic Development 001-0748
- Engineering 001-0742
- Fire Department 107-0110
- Forestry 001-0420
- Medina Recreation Center 574 Funds
- Parks 104 Funds
- Planning & Zoning 001-0410
- Police 106 Funds
- Service Director 001-0741
- Public Buildings 001-0743
- Street Department 102 and 103 Funds
- Water Department 513 Funds
- Sanitation Department 514 Funds
- Auto Mechanics 676-0746
- Street Lighting 001-0140

Detailed requests from each department requesting restoration of cuts are attached.

Estimated Cost:

Suggested Funding: Funding will need to be appropriated in the above accounts.

- Sufficient funds in Account No.
- Transfer needed from Account No. _____ to Account No. _____

NEW APPROPRIATION needed in Account No. _____

Emergency Clause Requested:

Reason:

COUNCIL USE ONLY:

Committee Action/Recommendation:

Council Action Taken:

Ord./Res.
Date:

Building Department

10% Budget Cuts due to Covid-19 concerns

If any reimbursements please return to:

General Fund - 001-0430

Line Item 50111 - Straight Time - Carry Forward

A handwritten signature in black ink, appearing to read "Dan Gladish". The signature is written in a cursive style with a large, sweeping initial "D".

Dan Gladish

Sherry Crow

From: Jarrod Fry <jfry@medinabees.org>
Sent: Wednesday, June 23, 2021 10:11 AM
To: Sherry Crow
Subject: Re: 10% Budget Cut reimbursement

Sherry,

Yes thanks for the reminder. My account number is 144-0730 Cable Department.

I would request to have my 10% reimbursed so that I can cover costs of salary of employees to cover the shortfalls we face in our five year budget. This is exactly what Council requested of me during my budget hearing.

Thanks,
Jarrod

On Tue, Jun 22, 2021 at 4:08 PM Sherry Crow <scrow@medinaoh.org> wrote:
Hi Jarrod,

Hope you enjoyed your time off - just a reminder that we need your brief summary requesting the 10% budget cut to be reimbursed. We need to submit RCA by early afternoon on Wednesday.

Thanks,
Sherry Crow
Administrative Office Manager/Mayor's Office
City of Medina
330-722-9020

--
Jarrod Fry
General Manager
MedinaTV
330-636-3456
jfry@medinabees.org

NOTICE: This e-mail message, including any attachments, is for the sole use of the intended recipient(s) and may contain confidential and/or privileged information, as defined by State and Federal laws. If you are not the intended recipient or an agent of the intended recipient, you are hereby notified that you received this message in error and any review, disclosure, copying, printing, distribution, dissemination, or the taking of any action in reliance on the contents of the information contained herein is strictly prohibited. If you received this e-mail message in error, please notify the sender by return e-mail, and immediately and permanently delete the original from your computer and destroy all copies of this communication. Thank you.

June 21, 2021

Economic Development / Grant Administrator - 001-0748

Budget - 10% Cut Reinstatement Request

52211 - Education & Travel would like to restore the \$4,844.00 to this account that was cut from the budget

Potential Travel in October 2021 - International Economic Development Council Annual Summit in Nashville, TN. Estimated costs are \$2,300.00 to include Registration, Hotel, Travel/Airfare, Meals, Parking

Chamber, MCEDC, OEDA Meetings and Webinars

52214 - Advertising Expense - would like to restore the \$8,565.00 to this account that was cut from the budget

(See attached sheet with Yellow Highlighted expenses for remainder of the year, will need to transfer funds from another line to cover all these costs).

52215 - Contractual Services - would like to restore the \$10,565 to this account that was cut from the budget

Annual Licensing Fee for Salesforce (Lightning Sales Cloud Enterprise Edition) - \$5,300.00

Other items TBD

**** 50111** - Additionally, per council, Barbara's position (Economic Development & Marketing Manager) position is paid for with Carry forward money, so any funds that are not used, will go towards her salary.

Respectfully,



Kimberly Marshall

Economic Development Director

June 18, 2021

Upcoming Advertising Expenses for the remainder of 2021

Medina Magazine Ad	
Double page ad	\$4,395.00
Single page ad	\$2,295.00
Medina County Visitor's Bureau Statewide Publication	
Full page ad	\$950.00
2021-2022 Visitor's Guide	
10,000 copies	\$1,800.00
12,000 copies	\$2,020.00
Site Selectors AD	
Double page spread	\$19,000.00
Cleveland Magazine	
Full page ad	\$5,335
Half page ad	\$2,995.00
Third page ad	\$2,060.00
Quarter page ad	\$1,590.00
Digital banner	\$300.00
Video ad (60 seconds)	\$500.00
Must be hosted on YouTube	
CM Promote Your City Issue June/October	
Full page ad	\$2,500.00
Digital ad	\$250.00
Crain's Cleveland Business	
Eighth page ad onetime	\$1,022.55 per time
Eighth page ad four times	\$920.55 per time
None of these prices include the cost of ad designs.	Estimate: \$2,000.00

Sherry Crow

From: Patrick Patton
Sent: Wednesday, June 23, 2021 9:06 AM
To: Sherry Crow
Subject: RE: Engineering Budget

Sherry-

Regarding the 10%, I anticipate using the funds for the following:

1. Salary for the Engineering Clerk position
2. Salary for the Engineering Intern position
3. Purchase of a new vehicle to replace the 1997 Ford F250

Let me know if you have any questions, thanks.

Patrick Patton, PE
City Engineer
City of Medina, Ohio

Phone: (330) 721-4721
Email: ppatton@medinaoh.org
Website: www.medinaoh.org

Medina City Hall / 132 N. Elmwood Avenue / Medina, Ohio 44256



From: Patrick Patton
Sent: Tuesday, June 22, 2021 5:08 PM
To: Sherry Crow <scrow@medinaoh.org>
Subject: Engineering Budget

Hi Sherry-

The Engineering Department would like to request reinstatement of the 10% budget reduction. Our Department is funded by account #001-0742.

Thanks,

Patrick Patton, PE

Medina Fire Department – Account # 107-0110

We are evaluating staffing models that would improve response times to calls for service on Saturday and Sunday. Estimated cost \$ 46,675 / year.

Aging buildings and properties:

- Station 1 complete parking lot replacement. Estimated cost \$ 440,000
- Station 2 driveway repair. Estimated cost \$ 8,000
- Station 3 complete roof replacement. Quoted cost \$ 24,500

Several sets of firefighter personal protective clothing will be expiring over the next three to five years. Total estimated replacement cost is \$ 104,000.

Chief Walters
6/22/21

Medina Recreation Center

2021 Budget Cuts \$249,000 from original 2021 Plan:

o Admin	Cut hiring of new program Specialist	\$82,295	Total	\$101,000
	▪ Cut OT, education, travel	\$6,000		
	▪ Advertising	\$5,000		
	▪ Operating, office, tools	\$8,000		
o Aquatics Staffing & contractual		\$60,000	Total	\$100,000
	▪ Supplies, chemicals & tools	\$40,000		
o Facility Staffing – rentals , MOD's			Total	\$16,000
o Guest Services Staffing – Front desk attendants			Total	\$16,000
o Program Staffing and instructors			Total	\$16,000

Plus unanticipated loss of two full time positions at \$11,000 per month for 8 months so far = \$88,000 savings

Revenue Replacement: Loss of \$987,000 revenues in 2020 over 2019's totals

If Budget cuts Reinstated:

Rebuild Staffing to recover lost part time positions: Priority: Increase Facility Monitors and Front Desk staffing!
Also increase allowable hours for pool manager, marketing, programming part timer staff.

- o Rehire one Full Time staff person when revenues hit 70% of normal year
- o Rehire second Full Time staff person when revenues hit 85-90% of normal year

Capital Projects to rebuild revenues and memberships:

Multipurpose / Aerobics flooring in 1200 sf meeting room that largely sat empty pre-2020. This will increase our class offerings during peak times, and be open to members for stretching, free weights and our TRX functional training rack when no classes are held. Would add sound system for classes.

Estimated cost: \$15,000

Reconfigure the front desk and lobby area to create a more efficient entrance flow and create a gathering area for some of our senior activities. The past year we have converted much of our information systems to an electronic format and do not need such a large storage space. We would rather use that space to give members a more appealing lobby. Needs tile work & new furnishings as well as architect's drawings.

Estimated cost: \$30,000

Conversion of café area into a Commons area for birthday parties and social gathering. The area was originally built for food service and has been used for vending since 2006. We would like to redecorate as a permanent party room that customers can reserve for birthday parties, etc. Currently the only party areas are in the front of the building, leading to trails of wet, barefoot children running through the lobby. The location is directly across from the pools and would help alleviate those issues. Requires painting, signage, acoustic panels for sound dampening, and new furnishings to accommodate more party attendees. The area will remain open to members unless reserved. Vending will be moved to the field house where the majority of teens and kids gather.

Estimated cost: \$5,000

Rebranding and image update for acoustic panels in 19 year old facility by reupholstering or replacing fabric covered panels that line the lobby and concourse with more modern, upbeat fabric. Prefer to reuse existing panels if possible, but estimate below is for replacement.

Estimated cost: \$12,000

Rebranding and image update via painting facility interior with vibrant colors and adding window / door graphics throughout building.

Estimated cost: \$10,000

Leisure Pool Fun Center atmosphere upgrade to complement the new jungle themed play feature. Wall murals and faux trees and plants will add to the ambience of the leisure pool. Repaint the underside and support beams of the giant slide to mimic a jungle tree house, and adding accessories that carry the theme and engage families.

Estimated cost: \$10,000

Fitness Equipment Replacement Project that will evaluate and replace aging equipment that is original to the building in 2002.

- Treadmills: \$100,000
- Free Weight Equipment: \$75,000
- Selectorized strength equipment: \$75,000
- Various cardio equipment and accessories: \$50,000

Total for all fitness equipment: \$300,000 – the majority to come from Carryforward Funds.

Meeting room updates – Convert front admin office large receptionist desk into a staff meeting space by adding conference table and chairs. Upgrade the community room furnishings with rolling stackable tables that can be easily placed in multiple configurations. Currently using folding white plastic tables that usually require two people to carry and set up. Reconfigure back admin office to provide adequate and efficient storage for all program supplies. This may just include moving existing front desk and admin office cabinets to the back office for storage.

Estimated cost: \$8,000

Total for all upgrades to facility with the intent to recapture lost members and appeal to families as well as senior and fitness enthusiasts: \$390,000

Parks Department 104 Accounts

2021 Budget Cuts **\$123,524** from original 2021 Plan:

- o Parks Budget Four Accounts Overall
 - Cut staffing \$26,524
 - Parks Operations and Equipment \$7,500
 - Maintenance of Parks Facilities \$14,500
 - Capital Buildings & Equipment \$35,000
 - Sports Fields Maintenance \$40,000

Cemetery 001-0210 and Forestry 001-0420

Cemetery and Forestry Budgets' Required 10% reductions were taken from Carryforward Funds.

If Budget cuts Reinstated:

Deferred Capital projects and vehicle/equipment purchases will be made. In all three departments maintenance and care of facilities cannot stop. Reduction in seasonal staff in 2020 has set us behind resulting in a greater need for 2021. Please see attached project list for parks with an estimated cost in excess of 1.5 million.

City of Medina Parks - Capital Improvements 2019 - 2024

	2019	2020	2021	2022	2023	2024
Community, Nature & Neighborhood Park Improvements	Improve dish-RG Upper Replace entry sign- HC, RE, RG, SM Various tree planting Install Memorial Bench at SM Install Permanent RR- SM Drainage improvements- JC	New concrete by permanent-RR- HG Replace entry sign- RM, JC Various tree planting Replace concrete by concession- RG New concrete by permanent-RR- RE Gasbo Painting- Upper- UP	Install more wildflower areas Replace entry sign- FG Various tree planting Mountain bike trail wash station- RG Dog Park Surface/Fence/Relocate Powder coat cans - UP	New small playground- ML Various tree planting Bandstand truck points - UP New concrete by permanent RR- RE Powder coat trash cans- UP Move dog park- RM	Various tree planting Crushed gravel along nature trail- NP Install permanent- RR- ML	Various tree planting
Equipment	3/4 ton truck purchase Pressure washer purchase Zero steer mower purchase Replace ball diamond groomer	3/4 ton truck purchase Replace Ventrac Replace field sprayer	4-6 week purchase Purchase new zero steer	3/4 Ton truck purchase Replace ball diamond groomer Replace field sprayer Replace wide area mower Replace zero steer mower	Replace landscape trailer LCF Truck Purchase Replace zero steer mower	3/4 ton truck purchase Replace zero steer mower
Tennis/Basketball Courts	Crack seal tennis court - KC Paint pickleball court- KC	Replace tennis court- post- RG		Crack seal basketball court - RM		Resurface tennis court- KC Replace tennis court post- KC
Sports Fields	Replace bleachers- RG Rebuild retaining wall RG #6 Build guard rail RG #6	Replace fence capping- RG Replace bleachers- RM Replace player benches- RG, RM	Replace bleachers- RG Replace fence capping- RM	Replace fence capping at FG Paint Bill Dunn Field House	Light- RG #4	
Parking Lots / Roads	Rear drive paving- RG	Seal/strip- Foundry lot- RM Strip parking- Vet- lower- RG	Resurface parking- RG Stripe foundry lot Stripe lot, ML, HC	Porch driveway- HC Resurface- KC Expand parking- RM	Pave parking- RE	Resurface parking- RG
Trails	Get in nature- self-serve- use- post- RG	Resurface/Seal multi-use path- RG Extend MPT on Reagan Pkwy.	Pave and reroute trail- RM	Resurface/seal multi-use path- RG	Gravel on trail - XT	
Structures	Pavilion Improvements- Lower- RG Wash and stain bridges- RE Construct new pavilion- JC Reagan 6 Dugout/ Concrete Paint Concession stand- RG Evaluate staffing needs Seasonal, PT, FT	Pavilion Ceiling- JC Footbridge replacement- RE Wash and stain pavilion- ML Replace RG driver stand- RG Rebuild City bridge HC Evaluate staffing needs- Seasonal Evaluate Turf Tech Position/ Anticipated Restroom	Bill Dunn field house painting- RG Foot bridge replacement- SM Replace RC driver stand- RG Build new seasonal pole barn Reagan 4 concession painting Evaluate staffing needs- Seasonal	Replace roof on pole barn- RG CXT Restroom- RE	CXT Restroom- HC	
Staffing				Evaluate staffing needs- Seasonal	Evaluate staffing needs- Seasonal	Evaluate staffing needs- Seasonal

Park Abbreviations
 Reagan = RG
 Jaycee = JC
 Kuehn/Todd = KT
 Memorial = ML
 Uptown = UP
 Nichols Park = NP
 Reagan = RM
 Sam Masi = SM
 Splash Pad = SP
 Reyan = RE
 Liberty = LY
 Roscoe Ewing = RE
 Sycamore = SY
 Ken Cleveland = KC
 Fred Greenwood = FG
 Weigh Station = WS
 Huffman/Cunningham = HC
 Feckley Lot = FL
 Sophia Victoria Trailhead = SV

Note: This schedule is for planning purposes only. Actual timeline may vary.
 Red = Complete
 Blue = In process



CITY of MEDINA
Community Development
Department

MEMORANDUM

TO: Mayor Dennis Hanwell

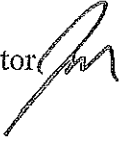
From: Jonathan Mendel, Community Development Director 

Date: June 21, 2021

Subject: 10% 2021 P&Z budget cut replacement (001-410)

General Fund Account: 001-410

Line

52211 – Education and Travel: return \$1,000 but no specific expenditures planned at this time

52214 – Advertising Expenses: return \$1,000 for code required Bds and Comm public notice requirements for the remainder of 2021 Boards and Commission cases

52215 – Contractual: return \$9,000 in case of additional contractual costs for current Comprehensive Plan creation process with OHM Advisors and Ohio Regional Development Corp's management of CHIP, CDBG-CV and CDBG Allocation grants, especially due to key staff shortages in Community Development

10% PLAN ----- 2021

Service Director Office – 001-0741-\$18,642 Vehicle- Equipment

Public Buildings – 001-0743 \$31,999 Make Whole Deficit from Cares Funding overages

Street Dept.- 102-0145 Traffic Control \$9,143- Equipment/ 102-0545 Leaf Collection-\$10,391-
Equipment/102- 0610 Street Maint. & Repair \$46,640 Building Improvements/102-0615-Street Cleaning-
\$35,775- Salt-Equipment/ 102-0620- Storm Sewer \$38,580 -Equipment/ Building Improvements /103-
0610-\$9,452- Salt

Water Office 513-0531- \$11,286 --Meter Equip/ Upgrades- GIS

Water Distribution-513-0533- \$360,743- Tank Painting / Building Construction

Sanitation Office- 514-0541- \$5,623- Recycling Program

Sanitation Collection- 514-0543- \$ 289, 532- Sanitation Truck/Container Replacements/ Building
improvements

Auto Mechanics Revolving-676-0746- \$41,469 Shop upgrades /Building improvements

Street Lighting 001-0140- \$21,000 cover State Capital Grant expenditures

RCA 21-142-6/28
Finance

ORDINANCE NO. ____-20

AN ORDINANCE TO APPROVE, ADOPT AND ENACT
CURRENT REPLACEMENT PAGES TO THE
CODIFIED ORDINANCES OF THE CITY OF MEDINA,
OHIO.

WHEREAS: Various ordinances of a general and permanent nature have been passed which should be included in the Codified Ordinances of the City of Medina, Ohio; and

WHEREAS: Certain traffic and misdemeanor ordinances should be revised to comply with current State law; and

WHEREAS: The codification of such ordinances, together with the new matter to be adopted, the matters to be amended and those to be repealed are before the Council.

NOW, THEREFORE, BE IT ORDAINED BY THE COUNCIL OF THE CITY
OF MEDINA, OHIO:

SEC. 1: That the ordinances of the City of Medina, Ohio, of a general and permanent nature, as revised, recodified, rearranged and consolidated into component codes, titles, chapters and sections within the 2021 Replacement Pages to the Codified Ordinances, which are hereby attached to this Ordinance as Exhibit A, are hereby approved and adopted.

SEC. 2: The following sections of the Traffic and General Offenses Codes, as amended, are hereby approved and adopted as amended or enacted so as to conform to enactments of the Ohio General Assembly:

Traffic Code

- 301.183 Low-Speed Micromobility Device. (Added)
- 301.22 Pedestrian. (Amended)
- 301.51 Vehicle. (Amended)
- 331.37 Driving Upon Sidewalks, Street Lawns or Curbs. (Amended)
- 331.42 Wearing Earplugs or Earphones Prohibited. (Amended)
- 335.04 Certain Acts Prohibited. (Amended)
- 371.13 Operation of Personal Delivery Device on Sidewalks and Crosswalks. (Added)
- 371.14 Low-Speed Micromobility Devices. (Added)
- 373.14 Motorized Bicycle Operation. (Amended)
- 373.12 Electric Bicycles. (Amended)

General Offenses Code

- 501.99 Penalties for Misdemeanors. (Amended)
- 505.071 Cruelty to Companion Animals. (Amended)
- 509.07 Making False Alarms. (Amended)
- 513.01 Drug Abuse Control Definitions. (Amended)
- 521.07 Littering and Deposit of Garbage, Rubbish, Junk, Etc. (Amended)
- 525.13 Interfering with Civil Rights. (Amended)
- 529.01 Liquor Control Definitions. (Amended)
- 533.08 Procuring; Engagement in Sexual Activity for Hire. (Amended)
- 533.09 Soliciting. (Amended)
- 533.091 Loitering to Engage in Solicitation. (Amended)
- 533.10 Prostitution. (Amended)
- 537.02 Vehicular Homicide and Manslaughter. (Amended)
- 537.17 Reserved. (Previously "Criminal Child Enticement")
- 541.04 Criminal Mischief. (Amended)
- 541.05 Criminal Trespass. (Amended)
- 541.051 Aggravated Trespass. (Amended)
- 549.02 Carrying Concealed Weapons. (Amended)
- 549.06 Unlawful Transactions in Weapons. (Amended)
- 553.04 Railroad Vandalism. (Amended)

SEC. 3: That it is found and determined that all formal actions of this Council concerning and relating to the passage of this Ordinance were adopted in an open meeting of this Council, and that all deliberations of this Council and any of its committees that resulted in such formal action, were in meetings open to the public, in compliance with the law.

SEC. 4: That this Ordinance shall be in full force and effect at the earliest period allowed by law.

PASSED: _____

SIGNED: _____
President of Council

ATTEST: _____
Clerk of Council

APPROVED: _____

SIGNED: _____
Mayor

INSTRUCTIONS FOR INSERTING
2021 REPLACEMENT PAGES
FOR THE
CODIFIED ORDINANCES OF MEDINA

All new replacement pages bear the footnote "2021 Replacement". Please discard old pages and insert these new replacement pages immediately as directed in the following table.

*Directory of
Officials*

Discard Old Pages

Insert New Pages

PRELIMINARY UNIT

<u>Discard Old Pages</u>	<u>Insert New Pages</u>
Cover and Certification Page	Cover and Certification Page
3, 4	3, 4
19, 20	19, 20
31, 32	31, 32
36A, 36B	36A, 36B
36 O, 36P	36 O, 36P
42I	42I
46G	46G
50G	50G
54A, 54B	54A, 54B
63, 64	63, 64

PART ONE - ADMINISTRATIVE CODE

36A, 36B	36A through 36B1
----------	------------------

PART THREE - TRAFFIC CODE

3, 4	3, 4
7 through 12	7 through 12B
59, 60	59, 60
62A through 62D	62A through 62D
89, 90	89, 90
163, 164	163, 164
169, 170	169 through 170B
176A, 176B	176A, 176B

Discard Old Pages

Insert New Pages

PART FIVE - GENERAL OFFENSES CODE

12C through 12G	12C through 12H
15 through 16B	15 through 16B
20C through 20H	20C through 20H
25 through 28	25 through 28
44A, 44B	44A, 44B
50G, 50H	50G, 50H
50K, 50L (Keep 50M thru 50V)	50K through 50L2
51, 52	51, 52
56A through 58B	56A through 58B
60W, 60X	60W, 60X
63 through 64D	63 through 64F
81 through 84	81 through 84
87, 88	87, 88
93, 94	94, 94

PART NINE - STREETS, UTILITIES AND PUBLIC SERVICES CODE

17 through 20 (Keep 20A, 20B)	17 through 20
21, 22	21, 22